

Tilt-Back Tire Changer

Installation and Operation Manual

Manual P/N 5900346 — Manual Revision C3 — November 2022

Models:

- R76LT
- R76ATR
- R76ATR-L



R76LT



R76ATR

Designed and engineered in Southern California, USA. Made in China.

 **DANGER**

Read the *entire contents* of this manual *before* using this product. Failure to follow the instructions and safety precautions in this manual can result in serious injury or death. Make sure all other operators also read this manual. Keep the manual near the product for future reference. *By proceeding with setup and operation, you agree that you fully understand the contents of this manual and assume full responsibility of product use.*

Manual. R76LT/ATR Tilt-Back Tire Changers, *Installation and Operation Manual*, Manual P/N 5900346, Manual Revision C3, released November 2022.

Copyright. Copyright © 2022 by BendPak Inc. All rights reserved. You may make copies of this document if you agree that: you will give full attribution to BendPak Inc., you will not make changes to the content, you do not gain any rights to this content, and you will not use the copies for commercial purposes.

Trademarks. BendPak, the BendPak logo, Ranger, and the Ranger logo are registered trademarks of BendPak Inc. All other company, product, and service names are used for identification only. All trademarks and registered trademarks mentioned in this manual are the property of their respective owners.

Limitations. Every effort has been made to have complete and accurate instructions in this manual. However, product updates, revisions, and/or changes may have occurred since this manual was published. BendPak Ranger reserves the right to change any information in this manual without incurring any obligation for equipment previously or subsequently sold. BendPak Ranger is not responsible for typographical errors in this manual. You can always find the latest version of the **manual for your product on the Ranger website**.

Warranty. The BendPak Ranger warranty is more than a commitment to you: it is also a commitment to the value of your new product. For full warranty details, contact your nearest BendPak Ranger dealer or visit bendpak.com/support/warranty. Go to bendpak.com/support/register-your-product/ and fill out the online form to register your product (be sure to click **Submit**).

Safety. Your new product was designed and manufactured with safety in mind. Your safety also depends on proper training and thoughtful operation. Do not set up, operate, maintain, or repair the unit without reading and understanding this manual and the labels on it; **do not use this product unless you can do so safely!**

Owner Responsibility. In order to maintain your product properly and to ensure operator safety, it is the responsibility of the product owner **to read and follow these instructions**:

- Follow all installation, operation, and maintenance instructions.
- Make sure product installation and operation conforms to all applicable local, state, and federal codes, rules, and regulations, such as state and federal OSHA regulations and electrical codes.
- Read and follow all safety instructions. Keep them readily available for operators.
- Make sure all operators are properly trained, know how to safely operate the unit, and are properly supervised.
- Do not operate the product until you are certain that all parts are in place and operating correctly.
- Carefully inspect the product on a regular basis and perform all maintenance as required.
- Service and maintain the unit only with approved replacement parts.
- Keep the manual with the product and make sure all labels are clean and visible.
- **Only use this product if it can be used safely!**

Unit Information. Enter the Model Number, Serial Number, and the Date of Manufacture from the label on your unit. This information is required for part or warranty issues.

Model: _____

Serial: _____

Date of Manufacture: _____

Table of Contents

| | | | |
|--------------------------------------|-----------|---------------------------------|-----------|
| Introduction | 3 | Operation | 33 |
| Shipping Information | 4 | Maintenance | 61 |
| Safety Considerations | 4 | Troubleshooting | 64 |
| Components | 6 | Wiring Information | 65 |
| FAQs | 9 | Labels | 66 |
| Specifications | 10 | Parts | 69 |
| Installation Checklist | 11 | Maintenance Log | 94 |
| Installation | 12 | | |
| Assist Arm Installation | 29 | | |

Introduction

This manual describes the following models in the R76 Series of Tilt-Back Tire Changers:

- **R76LT.** 3 HP, 220 VAC, Tilt-Back Tire Changer, no Assist Tower.
- **R76ATR.** 3 HP, 220 VAC, Tilt-Back Tire Changer with Assist Tower.
- **R76ATR-L.** 2 HP, 110 VAC, Tilt Back Tire Changer with Assist Tower.

More information about BendPak Ranger products is available at rangerproducts.com.

This manual is mandatory reading for all users of the R76 Series Tire Changers, including anyone who sets up, operates, maintains, or repairs them.

You can always find the latest version of the [manual for your product on the Ranger website](#).

 DANGER Be very careful when setting up, operating, maintaining, or repairing this equipment; failure to do so could result in property damage, product damage, injury, or (in very rare cases) death. Make sure only authorized personnel operate this equipment. All repairs must be performed by an authorized technician. Do not make modifications to the unit; this voids the warranty and increases the chances of injury or property damage. Make sure to read and follow the instructions on the labels on the unit.

Keep this manual on or near the equipment so that anyone who uses or services it can read it.

Technical support and service for your Tire Changer is available from your distributor or by calling **BendPak Ranger at (805) 933-9970**. You may also call regarding parts replacement (please have the serial number and model number of your unit available).

Shipping Information

Your equipment was carefully checked before shipping. Nevertheless, you should thoroughly inspect the shipment **before** you sign to acknowledge that you received it.

When you sign the bill of lading, it tells the carrier that the items on the invoice were received in good condition. **Do not sign the bill of lading until after you have inspected the shipment.** If any of the items listed on the bill of lading are missing or damaged, do not accept the shipment until the carrier makes a notation on the bill of lading that lists the missing or damaged goods.

If you discover missing or damaged goods **after** you receive the shipment and have signed the bill of lading, notify the carrier at once and request the carrier to make an inspection. If the carrier will not make an inspection, prepare a signed statement to the effect that you have notified the carrier (on a specific date) and that the carrier has failed to comply with your request.

It is difficult to collect for loss or damage after you have given the carrier a signed bill of lading. If this happens to you, file a claim with the carrier promptly. Support your claim with copies of the bill of lading, freight bill, invoice, and photographs, if available. Our willingness to assist in helping you process your claim does not make us responsible for collection of claims or replacement of lost or damaged materials.

Safety Considerations

Read this manual carefully before using your new product. Do not set up or operate the product until you are familiar with all operating instructions and warnings. Do not allow anyone else to operate the product until they are also familiar with all operating instructions and warnings.

 **WARNING California Proposition 65 Warning.** This product can expose you to chemicals including styrene and vinyl chloride which are on the list of over 900 chemicals identified by the State of California to cause cancer, birth defects or reproductive harm. **ALWAYS** use this product in accordance with BendPak's instructions. For more information go to **www.P65Warnings.ca.gov**.

 **WARNING** There are many moving parts on a Tire Changer; keep clear of these moving parts and the Tire being changed. In particular, when inflating a Tire, never lean over the Tire; if it were to explode (which does happen), the force could injure or kill the Operator or bystanders. During inflation, the Operator should be as far away from the Tire as possible, and all bystanders must be at least 30 feet away.

Safety Information

Please note the following:

- The product is a Tire Changer. **Use it only for its intended purpose.**
- The product **must** only be operated by authorized, trained, and properly supervised personnel. Keep children and untrained personnel at least 30 feet away from the product when it is in use.
- Always follow all applicable local, state, and federal codes, rules, and regulations, including (but not limited to) OSHA standard 1910.177 (Servicing multi-piece and single piece rim wheels).
- You **must** wear OSHA-approved (publication 3151) personal protective equipment at all times when installing, using, maintaining, or repairing the Tire Changer: leather gloves, steel-toed work boots, eye protection, back belts, and hearing protection **are mandatory.**

-
- Do not use the product while tired or under the influence of drugs, alcohol, or medication.
 - Do not use the product in the presence of cigarette smoke, dust, or flammable liquids or gases. Use the product indoors in a well-ventilated area. This equipment has internal arcing or sparking components which should not be exposed to flammable vapors. This machine should not be located in a recessed area or below floor level.
 - Guard against electric shock. This equipment must be grounded to protect the operator. Never connect the green power cord wire to a live terminal.
 - The motor on this machine contains high voltage. Disconnect power at the receptacle before performing any electrical repairs.
 - Do not make any modifications to the product; this voids the warranty and increases the chances of injury or property damage. **Do not modify any safety-related features in any way.**
 - Make sure all Operators read and understand this *Installation and Operation Manual*. Keep the Manual near the device at all times.
 - Make a visual inspection of the product every day. Do not use the product if you find any missing or damaged parts. Instead, take the unit out of service, then contact an authorized repair facility, your distributor, or **BendPak Ranger at (805) 933-9970**.
 - BendPak Ranger recommends making a **thorough** inspection of the product once a month. Replace any damaged or severely worn parts, decals, or warning labels.

Symbols

Following are the symbols that may be used in this manual:



DANGER Calls attention to a hazard that **will** result in death or injury.



WARNING Calls attention to a hazard or unsafe practice that **could** result in death or injury.



CAUTION Calls attention to a hazard or unsafe practice that could result in personal injury, product damage, or property damage.



NOTICE Calls attention to a situation that, if not avoided, could result in product or property damage.



Tip Calls attention to information that can help you use your product better.

Liability Information

BendPak Ranger Inc. assumes **no** liability for damages resulting from:

- Use of the product for purposes other than those described in this manual.
- Modifications to the equipment without prior, written permission from BendPak Inc.
- Injury or death caused by modifying, disabling, overriding, or removing safety features.
- Damage to the equipment from external influences.
- Incorrect operation of the equipment.

Components

The following graphic identifies the main components of the R76LT Tire Changer.

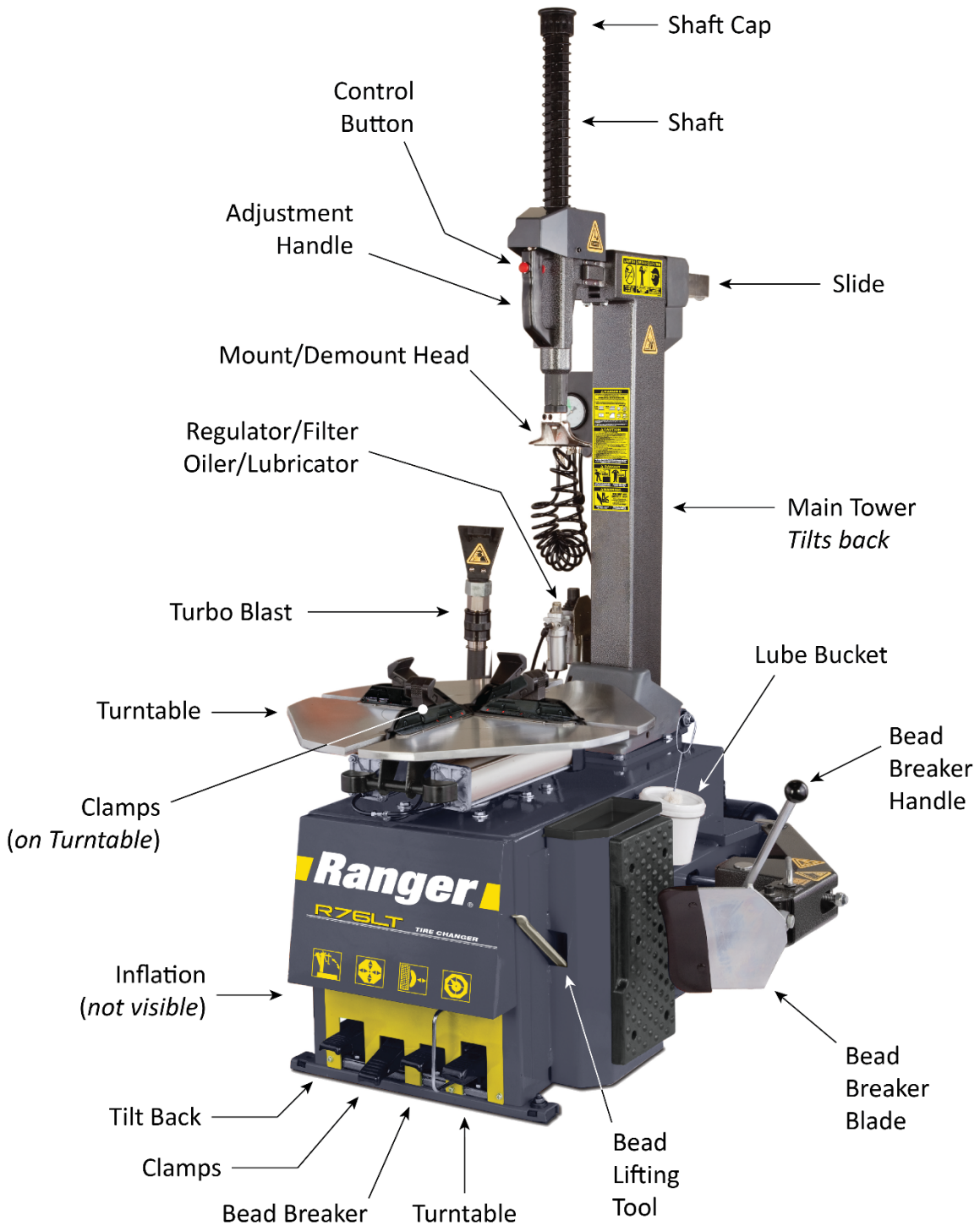

Front and right-side views. Components on left side and rear not visible.

The following graphic identifies the main components of the R76ATR Tire Changer.

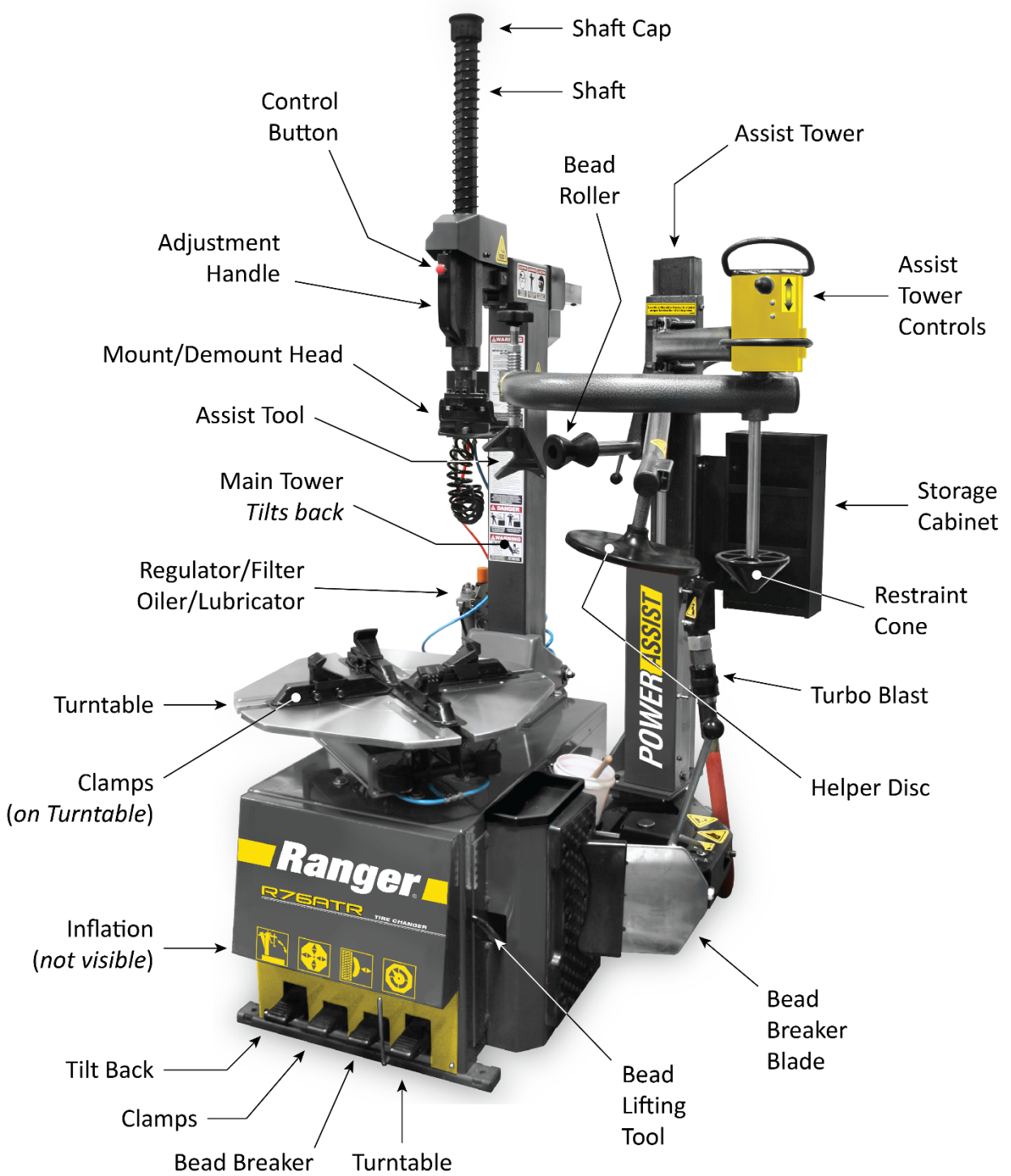

Front and right-side views. Components on left side and rear not visible.

Tire Changer components include:

- **Turntable.** Holds the Wheel.
- **RimGuard™ Wheel Clamps.** Durable, hardened plastic Clamps do not damage expensive Wheels as they hold the Wheel in place.
- **Main Tower.** Holds the Mount/Demount Head, tilts back so you can get it out of the way.
- **Mount/Demount Head.** Located on the bottom of the Shaft on the Main Tower, the Mount/Demount Head is used to both mount and demount Tires. The Tire Changer comes with two Mount/Demount Heads, one alloy-steel and one plastic polymer.
- **Shaft.** Moves the Mount/Demount Head up and down.
- **Shaft Cap.** Use to move the Shaft down to the desired height.
- **Control Button.** Locks and unlocks the Shaft and the Slide.
- **Bead Breaker.** Used to break the Beads of Tires before you demount them. Includes a Handle, Blade, and adjustable mechanism for pushing the Blade inwards to break the Bead.
- **Bead Lifting Tool.** Basically, a Tire Iron you use to pull the Bead edge of a Tire over the Mount/Demount Head so the Tire can be demounted from the Wheel. Can also be used to hold down a Tire Sidewall during Tire mounting.
- **Inflation Gauge.** Shows the amount of air pressure in the tire. Includes an Air Chuck with self-gripping clip, so you do not have to hold the Air Chuck in place as you inflate a Tire.
- **Turbo-Blast™ Bead Sealer.** Directs a burst of air pressure to help seal a difficult Bead.
- **Clamps Foot Pedal.** Moves the Clamps to the opposite position. If in, they move out. If out, they move in.
- **Bead Break Foot Pedal.** Moves the Bead Breaker Blade in.
- **Inflation Foot Pedal.** Controls putting air into a Tire. On left side of unit, not the front.
- **Turntable Foot Pedal.** Rotates the Turntable. Press down and hold down to rotate the Turntable clockwise, press up and hold up to rotate the Turntable counter-clockwise.
- **Tilt Foot Pedal.** Press and release to move the Main Tower to the opposite position: if close, moves it back; if back, moves it close.
- **Regulator/Filter and Oiler/Lubricator.** Control and route the incoming air.
- **Assist Tower.** R76ATR only. Holds several tools that can be used during mounting and demounting.
- **Restraint Cone.** R76ATR only. Used to hold the Wheel in place during inflation or to press down on the Wheel for external clamping.
- **Bead Roller.** R76ATR only. Holds the Sidewall of a Tire down during mounting; stays in a fixed position on the Tire as the Turntable turns the Tire.
- **Assist Tool.** R76ATR only. Holds the Sidewall of a Tire down during mounting; stays on the same spot as the Turntable turns the Tire.
- **Helper Disc.** R76ATR only. Holds up the Tire so it can be demounted.
- **Assist Tower Controls.** R76ATR only. Raises and lowers the Assist Tower Arms.
- **Storage Cabinet.** R76ATR only. For storing items, you want to have nearby.

Tire Changer accessories include:

- **Lube Bucket.** Holds Tire Lubricant.
- **Lube Brush.** Spreads Tire Lubricant.
- **Extra Air Line Parts.** Provided in case they are needed in the future.
- **Extra Yellow Plastic Pieces.** Provided in case they are needed in the future.

Frequently Asked Questions

Tire Changers remove Tires off of Wheels (called demounting) and reinstall Tires onto Wheels (called mounting). Below is a quick run-through of many of the terms used and questions.

Q: What is the difference between a Tire, Wheel, and Rim?

A: A Wheel is the round **metal** component that attaches to the Vehicle's axle. A Tire is the round **rubber** component that surrounds the Wheel. The outer edge of the Wheel, where the Tire attaches to the Wheel, is called the Rim. Often, the terms Wheel and Rim are used interchangeably.

Q: Some Tire Changers are described as "tilt back", what does that mean?

A: It means the Main Tower literally leans backwards, moving the Mount/Demount Head out of the way. Why is this beneficial? It allows you to set up the Mount/Demount Head in the right place for the Tire you are demounting/mounting, then move it out of the way, then bring it right back to the right place for the next Tire (Tires are generally demounted/mounted in sets of four) without having to adjust the Mount/Demount Head again.

Q: What does "break the Bead" mean?

A: A Tire is held on the Rim of a Wheel by the Tire Bead sitting between the Rim Lip and the Bead Retainer on the Rim. The air pressure in the Tire holds it in place once the Bead is seated (during mounting). When you "break the Bead", you move the Tire Bead out of the location where it was seated, which is required before you can take the Tire off the Wheel.

Q: What are the steps in the process of demounting a Tire and then mounting a new Tire?

A: The steps are: deflate the old Tire, break the Bead, secure the Wheel on the Turntable, demount the old Tire, mount the new Tire, inflate the new Tire, then remove the Wheel from the Turntable.

Q: Can I break the Bead without fully deflating the Tire first?

A: No. **Always fully deflate a Tire before attempting to break the Bead.** The air pressure energy in a Tire, even if not fully inflated, can be considerable. If you were to attempt to break the Bead of a Tire not fully deflated, that air pressure energy would be released all at once, possibly injuring or, in rare cases, killing the Operator or bystanders.

Q: Are tire and wheel sizes important when working with the Tire Changer?

A: You must exactly match Rim Width with the Tire you are mounting. The result of a mismatch is that the Tire could literally explode off the Wheel when you inflate it or while the Vehicle is being driven. In both cases, people could be injured or killed.

Q: Where should I put my Tire Changer?

A: What you want is a flat Concrete floor with room around it that is also near where you work on Tires. Ideally, you want it a little off the beaten path, as you must – for safety – keep everyone away from the Tire Changer while it is in use. No one other than the Operator should be within 30 feet of the Tire Changer while it is in use.

Q: Why isn't there a plug on the end of the Power Cord?

A: 220 VAC plugs vary by region, so if you are going to use a Power Cord with Plug, you need to use a Plug that is appropriate for the power outlet you will be using. The other power option is to wire the Tire Changer directly into the facility's power system. You **must have** a licensed Electrician perform all electrical work in accordance with all applicable electrical codes.

110 VAC units are prewired with a plug.

Specifications

| Model | R76ATR | R76LT |
|-----------------------------------------------|----------------------------------------------------------------------------------------------------|--------------------------------------------------------------------------------------------------|
| Motor 220 VAC | 3 HP, 208-240 VAC, 50/60 HZ, 1 Ph. | |
| Motor 110 VAC (R76ATR-L) | 2 HP, 110 VAC, 50/60 Hz., 1 Ph. (R76ATR-L model only) | |
| Power Cord Length | 96 in. (8 ft.) / 2,438 mm | |
| Drive System Type | Electric / Air | |
| Air Requirement | 140 – 165 PSI (9.6 – 11.4 BAR) | |
| Wheel Clamping | 4 Clamps – Internal / External | |
| Table Clamping | Dual Pneumatic Cylinders | |
| Bead Breaking | Pneumatic Power / Adjustable Blade | |
| Tower Design | Tilt Back | |
| Assist Tower | Single Assist Tower, Four Additional Tools | No Assist Tower |
| Bead Sealing | Turbo Blast | |
| Internal Rim Clamping | 10 – 30 in. (254 – 762 mm) | |
| External Rim Clamping | 9 – 28 in. (229 – 711 mm) | |
| Turntable Tire Width Capacity (Mounting) | 4 – 18 in. (102 – 457 mm) | |
| Bead Breaker Tire Width Capacity (Demounting) | 1.5 – 13 in. (38 – 330 mm) | |
| Maximum Tire Diameter | 43 in. (1,092 mm) | |
| Sound | <70 dB | |
| Dimensions | 75 in. wide* by 66 in. deep** by 79 in. high 1,905 mm wide* by 1,677 mm deep** by 2,007 mm high | 41 in. wide by 66 in. deep** by 79 in. high 1,042 mm wide by 1,677 mm deep** by 2,007 mm high |

* With Assist Arms at full extended width.

** With Main Tower tilted back and Slide all the way back.

Specifications subject to change without notice.

Installation Checklist

Following are the steps needed to install the Tire Changer. Perform them in the order shown.

- 1. Review the installation Safety Rules.
- 2. Make sure you have the necessary Tools.
- 3. Find an appropriate Location.
- 4. Make sure there is adequate Clearance around and above.
- 5. Unpack the Tire Changer.
- 6. Install the Tilt Tower, Inflation Gauge and Bead Breaker (R76LT Only).
- 7. Anchor the Tire Changer.
- 8. Connect to Power. ***Requires a licensed Electrician.***
- 9. Connect to Air.
- 10. Prepare the Lube Bucket.
- 11. Assist Arm Installation (R76ATR only).
- 12. Grease the Assist Tower Post (R76ATR only).
- 13. Test the Tire Changer.
- 14. Review the Final Checklist.

Installation

This section describes how to install your Tire Changer. Perform the tasks in the order presented.

⚠ DANGER When you even hear the words “Tire Changer,” you need to remember that being in close proximity to one is a serious endeavor with potentially life-threatening risks. Only allow appropriately trained, authorized, supervised personnel to install the Tire Changer. ***Do not assume that nothing bad is going to happen this time just because nothing bad happened last time.***

Installation Safety Rules

Pay attention at all times during installation. Use appropriate tools and equipment. Stay clear of moving parts. Keep hands and fingers away from pinch points. ***Safety is your top priority.***

⚠ WARNING You ***must*** wear OSHA-approved (publication 3151) personal protective equipment at all times when installing, using, maintaining, or repairing the Tire Changer: leather gloves, steel-toed work boots, eye protection, back belts, and hearing protection.

Use caution when unpacking the Tire Changer from its shipping container and setting it up. The Tire Changer is heavy, and the weight is not evenly distributed; dropping or knocking over the unit may cause equipment damage and personal injury.

Only experienced, trained technicians should install the Tire Changer. In particular, all electrical work ***must*** be done by a licensed, certified Electrician in accordance with all national and local electrical codes.

⚠ CAUTION Certain parts of installing the Tire Changer are difficult for just one person. BendPak Ranger ***strongly*** recommends having at least two or more persons work together to install the Tire Changer.

Tools

You may need some or all of the following tools:

- Open end Metric Wrenches
- Hex Keys or Hex Sockets, Metric
- Pliers
- Hammer or Mallet
- Pry Bar
- Utility Knife
- Screwdriver set, Slot and Phillips
- Rags
- Shop Crane or Forklift

Finding a Location

Keep the following in mind when deciding on a location:

- **Power source.** The Tire Changer needs to be near an appropriate power source.
- **Floor.** The Tire Changer is best used on a flat, Concrete floor.
- **Clearance.** The Tire Changer requires space around it. Refer to **Clearance** for more information.
- **Accessibility.** Surrounding working room is needed to move the Wheels and Tires while operating the Tire Changer.
- **Danger.** When a Tire is on the Tire Changer, especially during Inflation, keep everyone far away; only the Operator should be within 30 feet of the Tire Changer when it is in use.

Do not set up the Tire Changer in a well-travelled area.

- **No water.** The Tire Changer has electronic components. If the Tire Changer becomes wet while turned on, electronic components may short circuit and require replacement.

Set up the Tire Changer in a location where it will stay dry.

 **WARNING** Do not use the Tire Changer if it is setting in water. Potential short circuit conditions may exist, and the Tire Changer may electrocute personnel or bystanders.

Clearance

Working room around the Tire Changer is required.

⚠ WARNING The Clearance values shown below allow enough space to operate the Tire Changer. **For safety purposes, only the Operator should be within 30 feet of the Tire Changer while it is in use.**

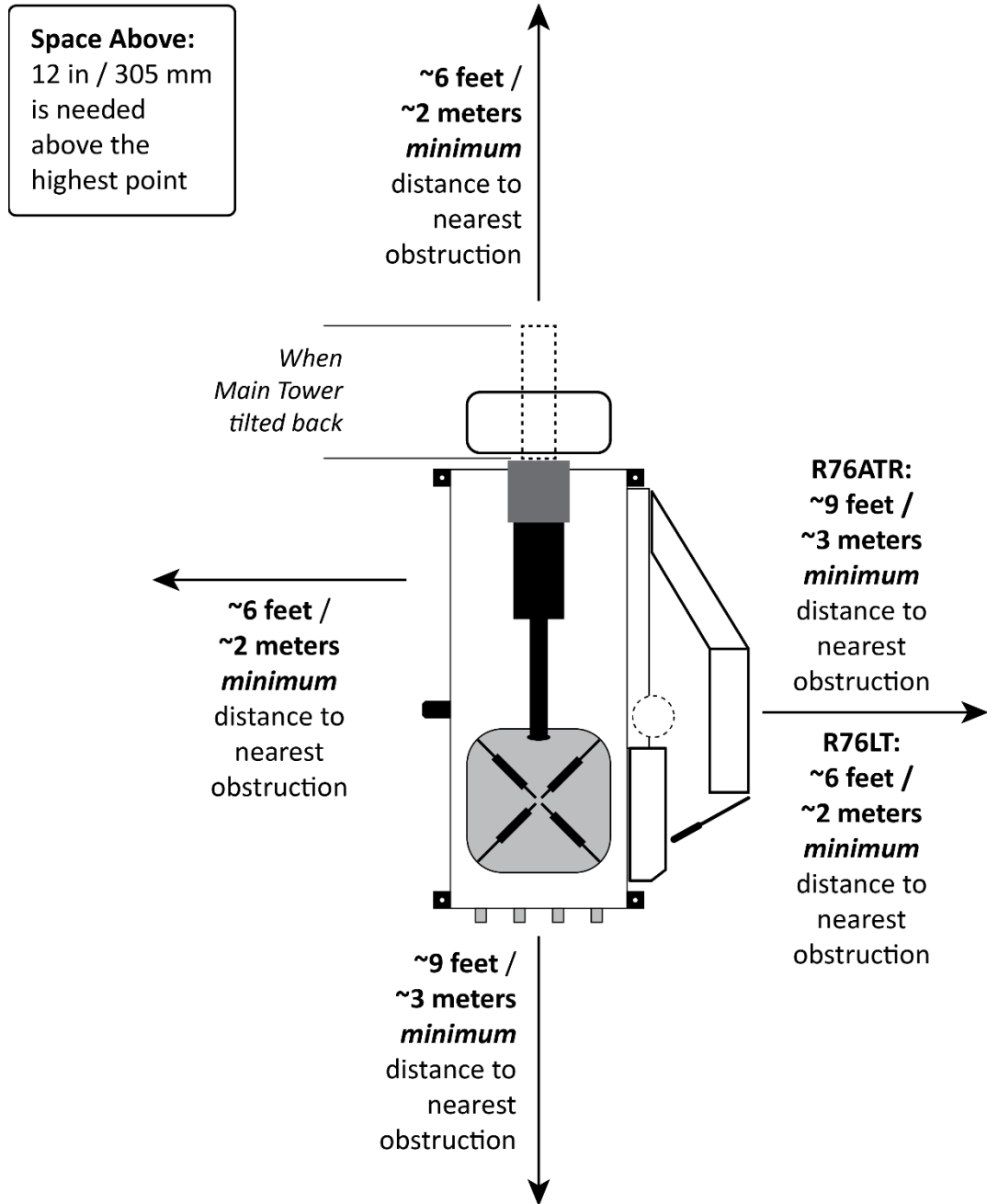

Top view. The additional room on the right for the R76ATR is for the Assist Arms.

Unpacking the R76LT and the R76ATR

Once you have found an appropriate location for the Tire Changer, you can move it into position, take off the Cover, and then take it off the Pallet.

Use caution when taking the Tire Changer out of its shipping container. You do not want to damage the unit, misplace any of the components that come with it, or may harm anyone.

⚠ WARNING Make sure to use an appropriate lifting device, such as a Forklift or Pallet Jack to move the Tire Changer while it is on its Pallet. Make sure **only** personnel who are trained in and experienced with material handling procedures are allowed to move the Tire Changer. The Tire Changer is heavy, and the weight is not evenly distributed; dropping or knocking over the unit may cause equipment damage or personal injury. BendPak Ranger recommends having at least two people work together to move the Tire Changer.

We recommend unpacking the Tire Changer as close as possible to where you are going to set it up.

To unpack the Tire Changer:

1. The Tire Changer is attached to a pallet and protected with a thin wood Cover. At the bottom of the Cover, use a Pry Bar or Screwdriver to push the metal tabs all the way down, on all four sides. You may have to apply some force to get all of the metal tabs free; they sometimes stick. Refer to the figure below.
2. Use a Pry Bar or Hammer to bend the metal tabs on all four sides of one panel. You may have to apply some force to get all of the metal tabs free. Refer to the figure below.
3. Remove panel.
4. Rotate the Cover off and set aside.

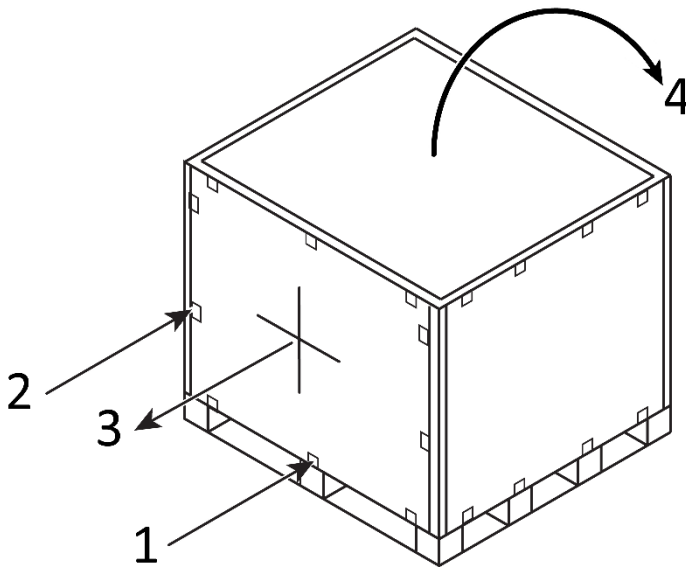

5. Move the R76ATR Tire Changer off the Pallet, and to the installation location.

The R76ATR may be moved off the Pallet using a Forklift under the left side or by lifting it using an appropriate lifting device (such as a Shop Crane) with a strap secured around the top of the Main Tower **and** the Assist Tower for the R76ATR.

Use care when moving the Tire Changer off the Pallet.

6. Remove the plastic wrap around the R76ATR and other components.
7. Free the components that are tied together on top of the R76ATR Tire Changer.

Installing the Tilt Tower, Inflation Gauge and Bead Breaker on the Tire Changer (R76LT Only)

The R76LT requires the Tilt Tower, Inflation Gauge and Bead Breaker to be installed at this point. After removing the shipping cover as described above, remove the components secured on the shipping pallet and install the Tower/Swing Arm, Inflation Gauge and Bead Breaker on the Tire Changer Cabinet as described below.

To Install the Tilt Tower on the Tire Changer:

 **WARNING** Wear OSHA-approved (publication 3151) Personal Protective Equipment: leather gloves, steel-toed work boots, back belts, hearing protection, and ANSI-approved eye protection (safety glasses, face shield, or goggles). Keep rags nearby to remove excess grease.

1. Remove the Accessories and Covers on top of the Tire Changer and store in a safe place for later use.
2. Carefully remove the plastic wrapping from the Tire Changer, but do not free the Tilt Tower located on the side of the Tire Changer.
3. Retain any parts located in bubble wrap or plastic bags and store with the Accessories previously removed.
4. The Tilt Tower is secured to the shipping pallet in several locations. **Carefully** remove the plastic and strap that secures the Tilt Tower to the Tire Changer.

 **WARNING** Use care when moving the Tilt Tower. The Tower is top heavy, and the weight is not distributed evenly. If it is dropped, you may injure yourself, bystanders or damage the equipment.

Use a lifting strap capable of supporting the Tilt Tower. Secure and orient the Tower using a Shop Crane or Forklift as shown below. Adjust the Lifting Straps or Chains to hold the Tilt Tower securely, oriented with the Tilt Tower base downwards.

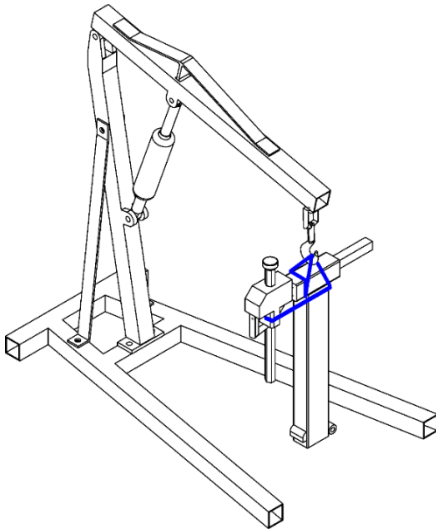

5. Move the Tilt Tower out of the way and secure from movement where it cannot fall and injure anyone. Do not remove the Lifting Straps or Chains until the Tower is secured on the Tire Changer.
6. Remove the side Service Access Panel (7 Screws).

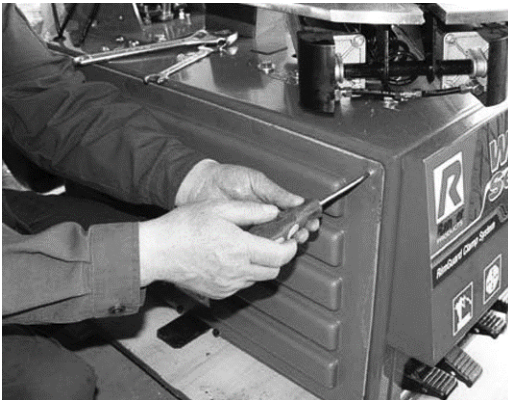

7. Remove the Air Regulator and Oiler (2 screws). Set aside where they will not be lost.

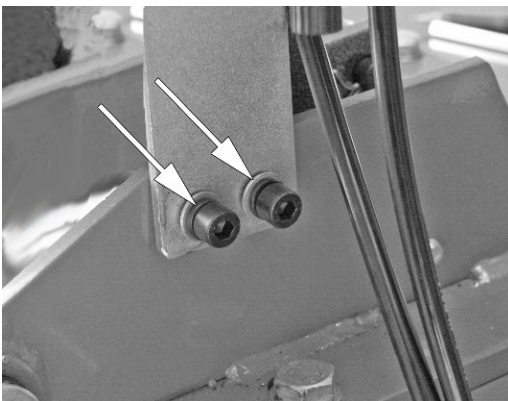

-
8. Remove the Tilt Tower Main Pivot Pin, Nuts and Washers from the Tire Changer. Set the Main Pivot Pin, Nuts and Washers aside to prevent loss.



9. Carefully move the Tilt Tower into place over the Tire Changer using a Forklift or Shop Crane. Take care not to damage the bottom of the Tilt Tower or the Air Line exiting the Tilt Tower.

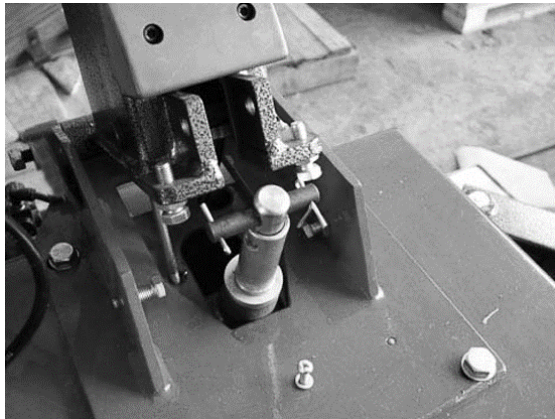

10. Remove one of the Snap Rings securing the Safety Pin and remove the Safety Pin from the Tilt Tower. Set these parts aside where they will not be lost.

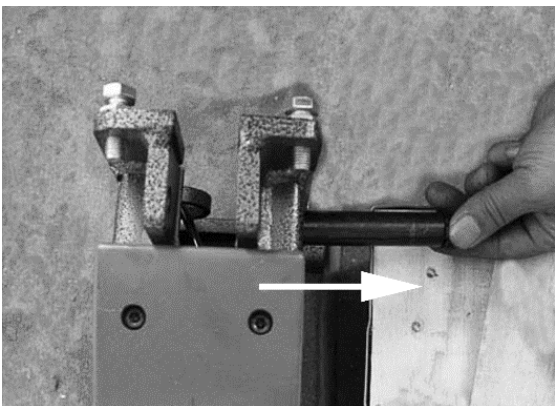

-
11. Remove Cotter Pins from the Tilt Tower Cylinder Pin and remove the Pin. Set aside where they will not be lost.

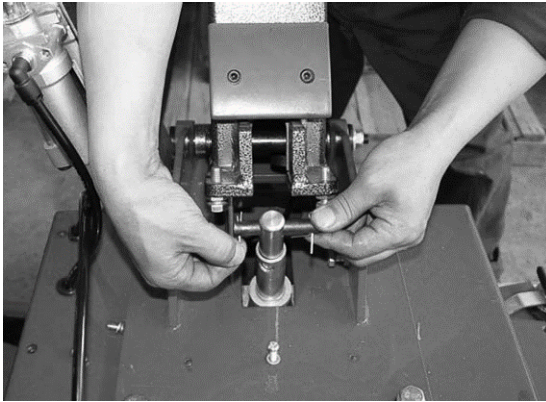

12. Feed the Air Line from the Tilt Tower into the Tire Changer base.

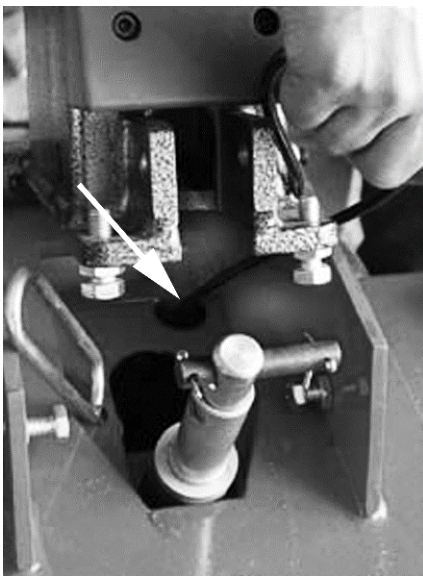

13. Insert the Main Pivot Pin through the holes in the Tire Changer Base and Tilt Tower. You may need to tap the Pivot Shaft lightly with a Hammer or Mallet to drive the Main Pivot Pin into place. Secure the Pivot Pin with the Washers and Nuts previously removed.

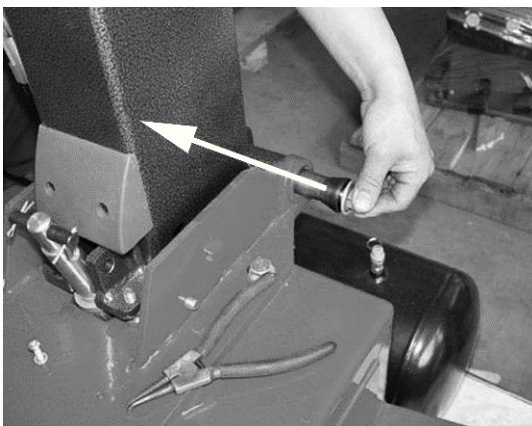

-
14. Align the Tilt Tower and the Safety Hook. Push the Tilt Tower Safety Pin through the Tower, and Safety Hook.

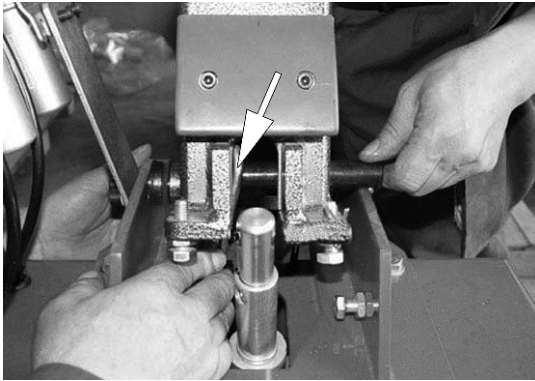

15. Verify the Pin passes through the Safety Hook. Secure the Safety Pin with Snap Rings.

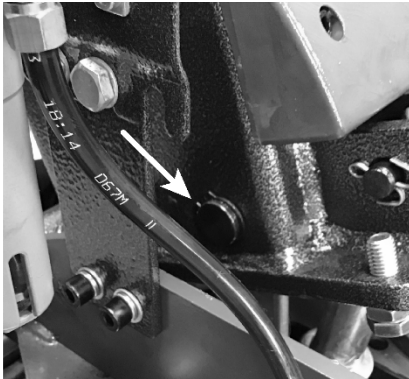

16. Align the Cylinder Shaft, Cylinder Pin and Tilt Tower opening. Insert the Cylinder Pin through the holes and secure with the Cotter Pins removed earlier. Bend to lock Cotter Pins in place.

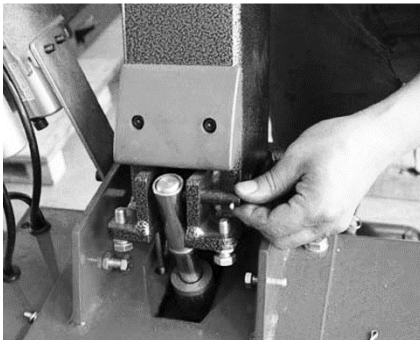

17. When the Tilt Tower is secure, you may remove the Lifting Straps or Chains from the Tilt Tower and move the Shop Crane or Forklift away from the work area.

18. Mount the Air Regulator and Oiler Back on Tire Changer Mount (2 Screws and Washers).

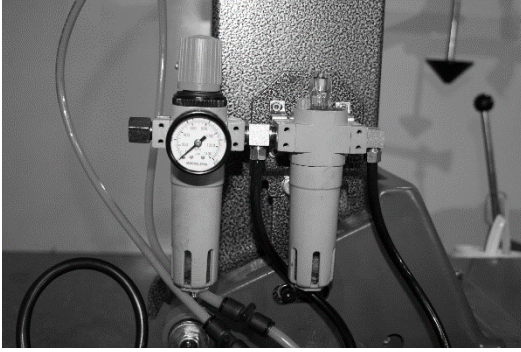

19. Locate the Black Air Line from the Tower inside the Tire Changer. Route the Air Line from the Tilt Tower out the back of the Tire Changer through the open hole with a Grommet.

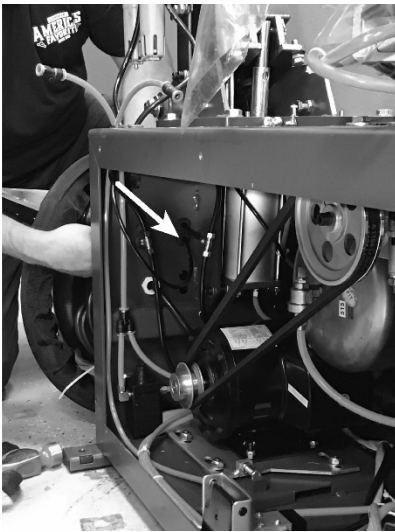

20. Connect the Black Air Line from the Tilt Tower to the Hose Compression Coupling on the back of the Tire Changer and tighten. Refer to the photo below.

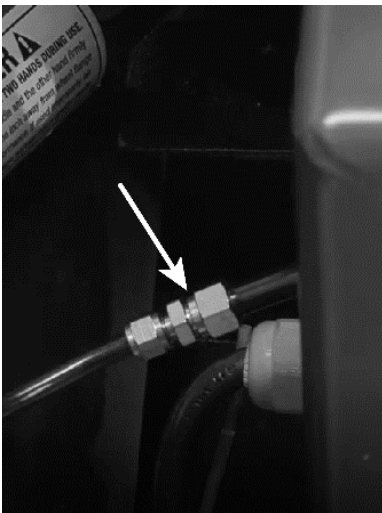

To Install the Inflation Gauge:

1. Locate the Inflation Gauge mounting on the left side of the Tilt Tower. Remove and retain the two M6 Machine Screws, Lock Washers, and Flat Washers, from the Tilt Tower.
2. Retrieve the Inflation Gauge from its bag or protective wrap. Orient the Inflation Gauge so the Air Lines are exiting at the bottom and the Gauge faces forward. Secure the Inflation Gauge to the Tilt Tower using the M6 Screws, Lock Washers, and Washers removed in the previous step. Refer to the photo below.



3. Route the Blue and Orange Air Lines from the Inflation Gauge behind the Air Pressure Regulator and Oiler into the push-to-connect Pneumatic Couplings on the Blue and Orange Air Lines coming out of the Tire Changer.

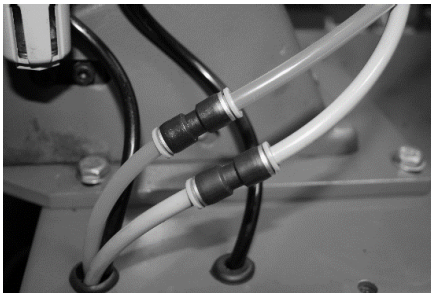

⚠ WARNING The Tire Changer uses pneumatic and electrical energy; if your organization has Lockout/Tagout policies, implement them once the unit is connected to the Air Source.

4. Install the Air Line Quick Disconnect using either PTFE Thread Sealant or Teflon[®] Tape.

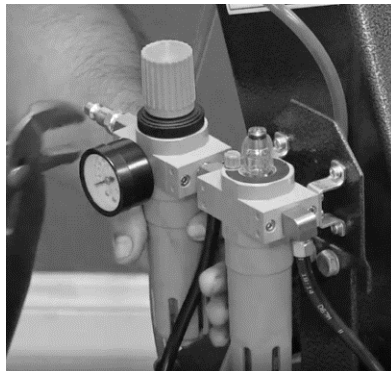

5. Replace the Service Access panel (seven M6 Machine Screws).
6. Remove the Air Regulator and Oiler to provide installation clearance for the plastic Tilt Tower Base Cover.
7. Install the Tilt Tower Base Cover (M6 Phillips Machine Screw).

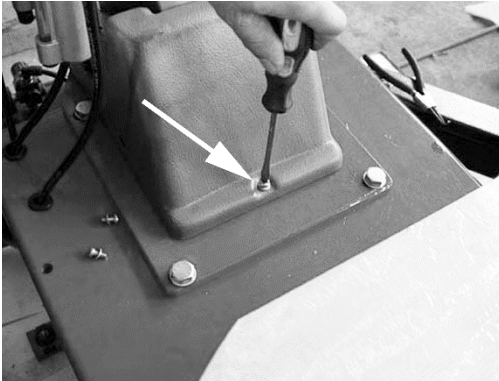

8. Install Air Regulator and Oiler.
9. Install back cover (two Hex Nuts).

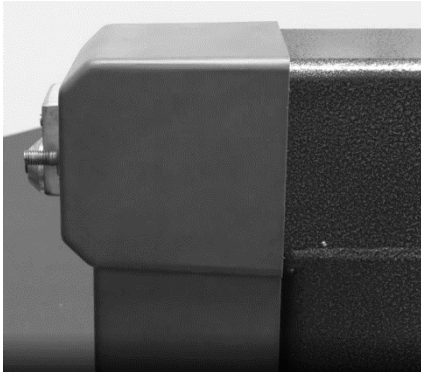

To Install the Bead Breaker:

1. Retrieve the Bead Breaker Blade from its plastic bag. Remove excess shipping grease, if necessary.
2. Remove the M14 x 95 mm Bolt, Lock Washer, and Lock Nut, from the Bead Breaker assembly.
3. Place the Bead Breaker Blade on to the Bead Breaker Arm and reinstall the M14 Bolt, Lock Washer, and Nut.



Anchoring the Tire Changer

The Tire Changer features anchoring points; anchoring is optional.

Note: You are not required to anchor the Tire Changer. BendPak Ranger recommends doing so though, as the Tire Changer uses force during the changing of a Tire. Anchoring ensures it will not move during operation.

The 0.5 in. / 12.7 mm holes for anchoring are located in the four corners of the Tire Changer base.

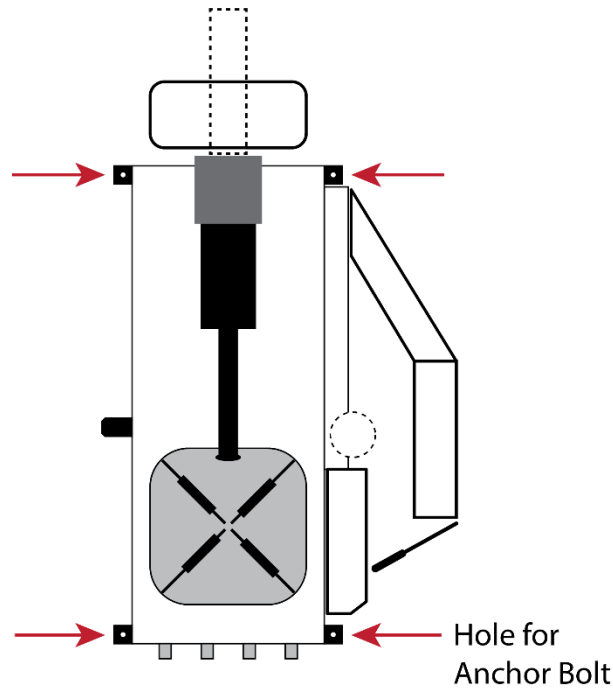

Anchor Bolts (sometimes called Wedge Anchors) mentioned in the following procedure are **not** supplied with the Tire Changer.

⚠ WARNING Before drilling, make sure that the slab is not a Post Tension slab. If so, mapping will be required to learn where the cables are positioned below the slab. If not, severe injury may occur if a cable is drilled into and releases. Also note that a masonry drill bit, hammer drill, and anchoring fasteners are all recommended to properly attach into suitable concrete.

To anchor the Tire Changer:

1. Ensure the Tire Changer is in the desired location.

Using the holes in the base as guides to mark exactly where the holes will be placed. Drill a 2.5 in. / 63.5 mm deep hole for each Anchor Bolt and Sleeve. Double check the Anchor Bolt and Sleeve's installation instructions to ensure they match these requirements. Be sure to install to solid concrete that is in good condition without excessive cracks.

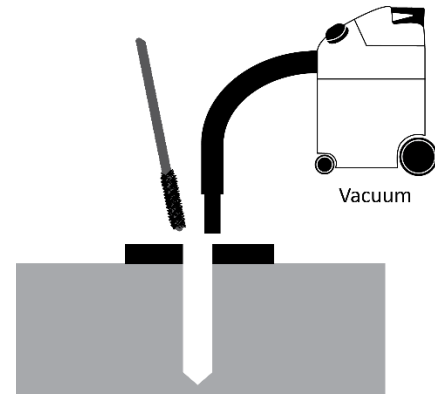
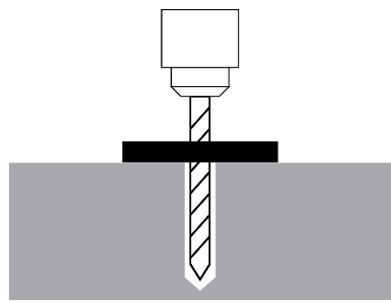

Use a drill bit that is the same diameter as the Anchor Bolt system's requirements.

Drill straight with a capable hammer drill; do not let the drill wobble. Use a carbide-tipped drill bit (conforming to ANSI B212.15).

2. Thoroughly clean each hole after drilling.

BendPak recommends using a wire brush and a vacuum to get the hole very clean.

Do **not** ream the hole. Do **not** make the hole any wider than the drill bit made it.

3. Make sure Washer and Nut are in place, insert Anchor Bolt with expansion sleeve in clean hole.

The Expansion Sleeve of the Anchor Bolt may prevent the Anchor Bolt from passing through the hole in the base of the Tire Changer; this is normal. Use a hammer or Mallet to tap the Expansion Sleeve through the base and down into the hole.

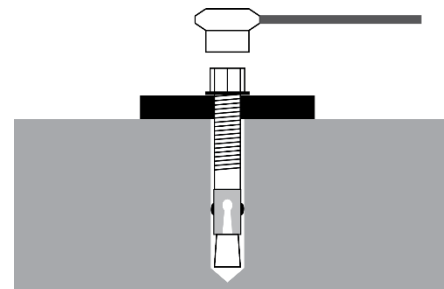
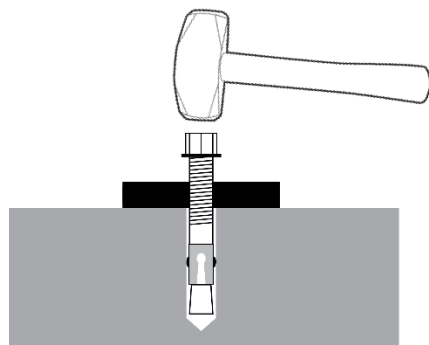

Even using a hammer or Mallet, the Anchor Bolt should only go into the hole part of the way; this is normal. If the Anchor Bolt goes all the way in with little or no resistance, the hole is too wide.

Once past the hole in the base, the Anchor Bolt eventually stops going down into the hole as the Expansion Sleeve contacts the sides of the hole; this is normal.

4. Hammer or Mallet the Anchor Bolt the rest of the way down into the hole.

Stop when the Washer is snug against the base of the Tire Changer.

5. Use a torque wrench to tighten each Nut **clockwise** to the torque recommended by the manufacturer of the Anchor Bolt.

If no torque is specified, BendPak Ranger recommends ~55 lbf-ft / 74 N-m for a 3/8 in diameter Anchor Bolt.

Important: Do **not** use an *impact* wrench to torque the Anchor Bolts.

Tightening the Nut by using a hand operated wrench, moves the Wedge up, while forcing out the Expansion Sleeve and pressing it tightly against the Concrete.

Connecting to Power

The **R76ATR-L** Tire Changer must be connected to a 110 VAC power source on a **dedicated 20 Amp circuit**. The 110 VAC units are prewired with a plug.

The **R76ATR** and **R76LT** Tire Changers must be connected to a 208-240 VAC power source, on a **dedicated 15 Amp circuit**.

A Power Cord with **no Plug** on the end is provided with the 220 VAC units. You must have a licensed, certified Electrician install either by:

- Wire the **R76ATR** or the **R76LT** Power Cord to an appropriate 208-240 VAC NEMA, 30 Amp Plug, which is then plugged in to an appropriate power outlet.
Or...
- Wire the Tire Changer directly into the facility's electrical system protected by an appropriate circuit breaker.

 **WARNING** The Tire Changer uses pneumatic and electrical energy; if your organization has Lockout/Tagout policies, implement them once the unit is connected to a power source.

Refer to **Wiring Information** for additional wiring information.

 **DANGER** **All** electrical work **must** be done by a licensed, certified Electrician in accordance with all local, state and National Electrical Codes (NEC). If you do not use a licensed, certified Electrician, you void your warranty and put everyone who uses the Tire Changer in danger of injury or, in rare cases, death.

Additional electrical information:

- Make sure wiring is done in accordance with National Electric Code (NEC) and local codes and standards covering electrical apparatus and wiring.
- Operation with NO Ground can damage electronics and could create a shock hazard. **You must GROUND the unit.**
- Damage caused by improper electrical installation is **not covered** by the warranty.
- Make sure adequate wire sizes are used, service is of adequate amperage rating, the supply line has the same electrical characteristics (voltage, cycle, and phase) as the motor, and that **no other equipment is operated from the same line.**
- Electrical codes in your area may require “hard-wiring” if the machine is anchored to the floor. Consult a licensed Electrician regarding the applicable codes for your location.

 **WARNING** **Disconnect power and air pressure before performing troubleshooting or maintenance.** Make sure the unit cannot be reenergized until you are done. This equipment has internal arcing or sparking parts that should not be exposed to flammable vapors. The unit must **not** be located in a recessed area or below floor level.

Connecting to Air

The Tire Changer requires a 15 to 25 CFM Air Source with an operating air pressure of 140 to 165 PSI (9.6 to 11.4 bar).

⚠ WARNING The Tire Changer uses pneumatic and electrical energy; if your organization has Lockout/Tagout policies, implement them once the unit is connected to the Air Source.

The air lines leaving the Regulator/Filter and Oiler/Lubricator should already be connected.

The incoming Air Source connects to the Tire Changer via the Air In connector on the Regulator/Filter. You need to provide a fitting for the Air In connector; which is not supplied.

⚠ WARNING Clear everything off the Turntable, and out of the path of the Tilt Tower **prior** to connecting the Tire Changer to pressurized air as table components will change position.

⚠ WARNING Stay clear of pinch points and moving components. Once Air Pressure is provided to the Tire Changer, the Tilt Tower will return to its upright position and the Wheel Clamps on the Turntable will move to the outside of the Turntable.

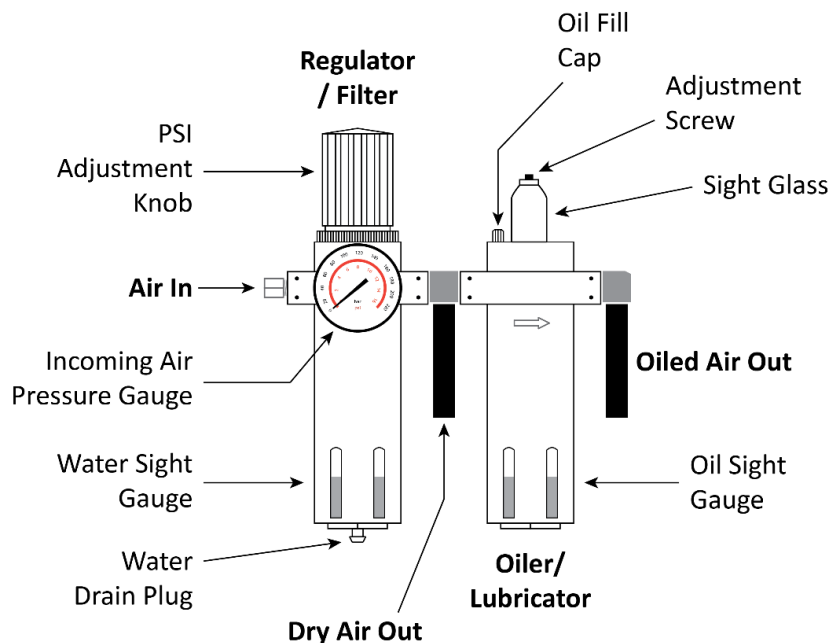

Drawing not necessarily to scale. Not all components shown.

The following drawing shows a quick-connect air fitting (shown on the left, below) that connects to the Air In connector (shown on the right, below). The fitting is **not** supplied with the Tire Changer.

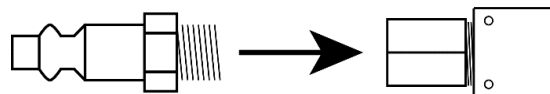

The **Regulator / Filter** removes contaminants from the incoming air. It also includes a gauge that shows the operating air pressure of the incoming air. If you see moisture in the Water Sight Gauge, you can drain it using the Water Drain Plug. Refer to **Maintenance** for more information.

The **Oiler / Lubricator** puts pneumatic oil, for lubrication, into the incoming air. This lubricated air is routed to pneumatic components of the Tire Changer.

Prepare the Lube Bucket

The Tire Changer comes with a Lube Bucket and a Lube Brush (to apply your Tire Lubricant).

BendPak Ranger does not include any Tire Lubricant with the Tire Changer, as there are many options available.

⚠ CAUTION Only use Tire Lubricant that is approved by the Tire manufacturer for the Tire you are changing. Using non-approved Tire Lubricant may corrode Wheels or cause Tire/Wheel slippage and vibration issues.

Be sure to use enough Tire Lubricant. Tire Lubricant **temporarily** reduces the friction between the Tire Bead area and the Rim. Remove excessive amounts of Tire Lubricant on the Tire or Rim.

There is a location on the Tire Changer specifically for the Lube Bucket.

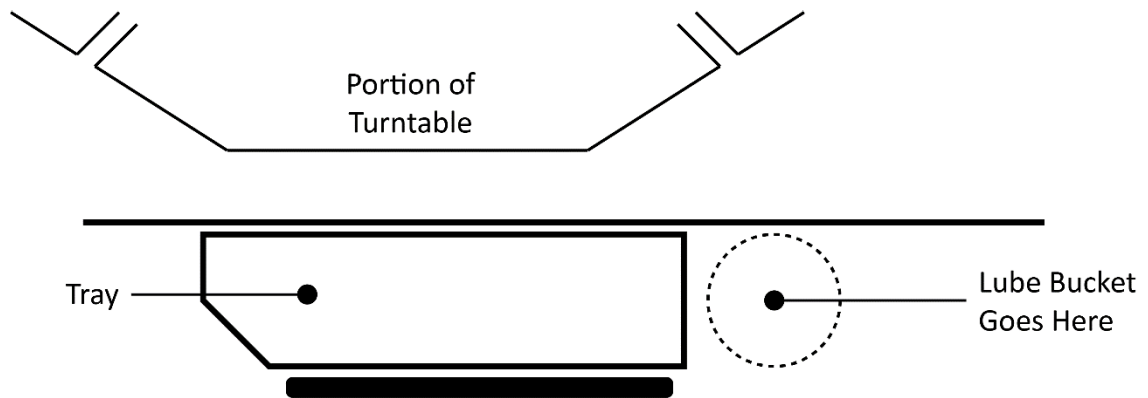

Top view. Not necessarily to scale. Not all components shown.

R76ATR Assist Arm Installation

The following are installation instructions for the Assist Arm and Tower for the R76ATR Tire Changer.

Tools Required: Metric Hex Wrench or Socket, a ratchet (3/8-in. drive ratchet recommended) and an alignment tool.

Installing the Assist Arm and Tower to the R76ATR Tire Changer

1. Carefully remove straps and attachments securing the Assist Arm and Tower to shipping crate.

⚠ WARNING The Assist Arm is heavy and awkward to handle.

You must wear proper protective equipment at all times during assembly of the Assist Arm: eye protection, head protection, leather gloves, steel-toed boots, and back belts are required.

2. Locate the Parts Box and remove the following fasteners.

| Qty. | Description |
|------|---------------------------|
| 4 | M8 x 30mm SHCS |
| 4 | M8 Split-Ring Lock Washer |
| 4 | M8 Flat Washer |

3. With two capable assistants or a shop crane, raise and set the Tower Assembly on the Tire Changer so that the 4 mounting baseplate holes closely align (by rotating the Tower) with the 4 corresponding threaded holes on the R76ATR Tire Changers' support weldment.

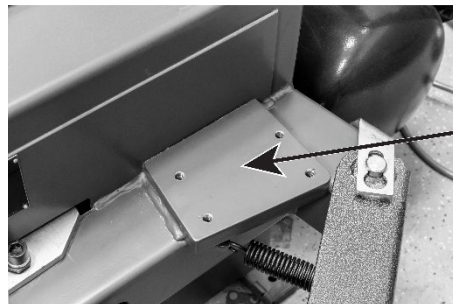
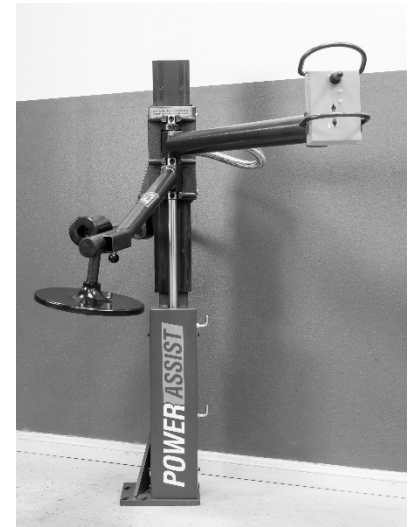

4. With the Tower placed into position to install, have one assistant continue holding the Tower in place, while rotating tower to exactly line up with all 4 threaded holes in weldment plate. Second assistant then installs the first hex bolt and washer handtight to 1 of 4 holes.
5. Next, install and handtighten the remaining 3 hex bolts and washers.
6. With all 4 hex head bolts and washers installed, use the appropriate hex wrench or socket to snug first, and then securely tighten all 4 fasteners in a crisscross fashion. Check and retighten all 4 fasteners again to ensure they are secure.



7. Install the toolbox tightly to the tower (arrows).

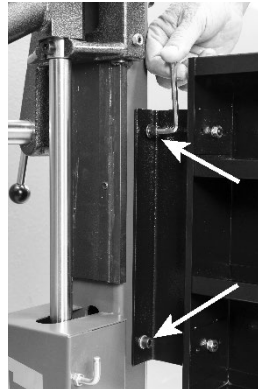

8. Next, connect the Black Air Line from the Assist Tower to the coupling on the Black Air Line from the Cabinet. This operation is accomplished by pushing onto the hose barb and tightening securely. Check R76ATR Assist Arm and Tower's operation with a "takeoff" wheel and tire. The installation is now complete.

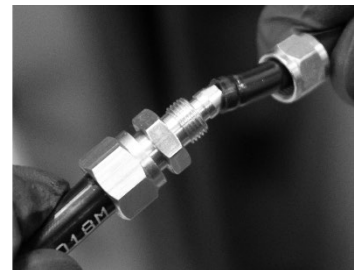

Technical support and service is available from your BendPak Ranger dealer, on the Web, by email at support@bendpak.com, or by phone at **(805) 933-9970**. You may also contact BendPak for parts replacement information (please have the model and serial number of your unit available) at **(800) 253-2363**, extension 191.



Grease the Assist Tower Post (R76ATR Only)

The Assist Tower Post on the R76ATR needs to be periodically greased to allow the Assist Tower Arms to easily slide.

The Tire Changer comes from the factory with the Assist Tower Post already greased; however periodic lubing is required.

BendPak Ranger recommends a lithium-based grease that includes molybdenum and graphite. For example, Extreme Pressure Moly-Graph® Multi-Purpose Grease from CRC/Sat-Lube®.

⚠ CAUTION The lithium-based grease for lubricating the Assist Tower Post is **not** a Tire Lubricant.

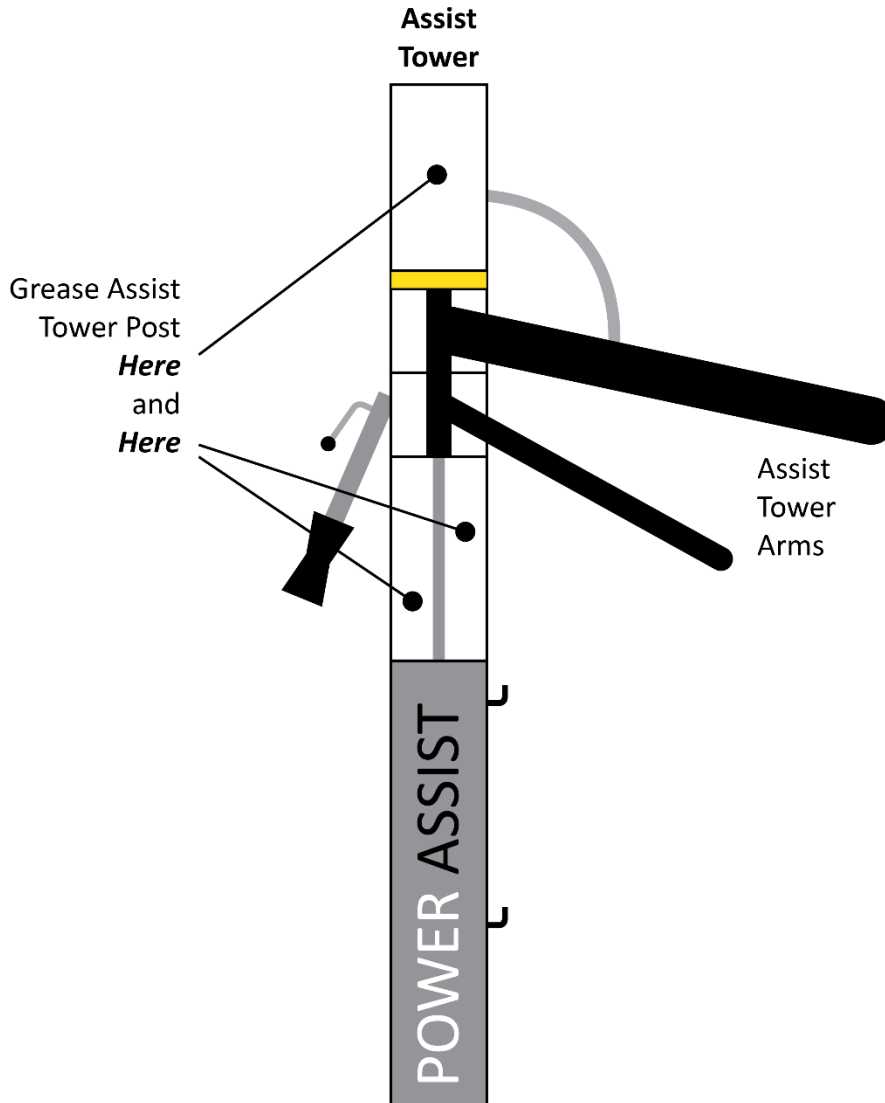

Side view. Not necessarily to scale. Not all components shown.

Test the Tire Changer

Make sure the following have been completed **before** putting the Tire Changer into normal operation:

- **Check for pneumatic pressure.** The Tire Changer requires pneumatic pressure to perform certain functions.
To see if the Tire Changer has air pressure, take the Air Chuck and lightly step on and hold down the Inflation Foot Pedal.
- **Test the power source.** Other Tire Changer functions require electric power. Step on and hold down the Turntable Foot Pedal to check for electric power. If the Turntable turns, you have power.
- **Make sure there is Tire Lubricant available.** Your shop probably has a brand of Lube that it prefers. Make sure some is in the Lube Bucket on the Tire Changer. Always use Lube; it makes changing Tires easier and helps prevent damage to the Tire and the Wheel.
- **Test the Tool Arms on the Assist Tower (R76ATR only).** Manually move each Tool Arm separately from side to side. Use the Assist Tower Controls to raise and lower the Tool Arms (they move up and down together). If the Tool Arms can perform these operations, equipment is working correctly.
- **Change some Take-Off Tires.** To get used to the Tire Changer, BendPak Ranger strongly recommends that all potential Operators change multiple *non-customer Tires of different types* **before** changing customer tires.

Final Checklist Before Operation

Perform the following **before** putting Tire Changer into normal operation:

- Review the Installation Checklist to make sure all steps have been performed.
- Make sure the Tire Changer is supplied electrical and pneumatic power.
- Check to see that all Anchor Bolts are in position and tightened; if installed.
- Make sure the Tire Changer has been used to change some non-customer Tires.
- Leave the Manual with the owner/operator.

Operation

This section describes how to use your Tire Changer.

It shows and describes the main Tire Changer components involved in demounting and mounting Tires, followed by the necessary procedures.

⚠ DANGER Being in close proximity to a Tire Changer is a serious endeavor with potentially life-threatening risks. Only trained, authorized, supervised personnel may be within 30 feet of the Tire Changer while it is in use. **Do not assume you are going to be safe, make sure you will be safe.**

Usage Precautions

Keep the following in mind while you use your Tire Changer:

- Make sure all employees receive specific training for Tire demounting and mounting **before** they are allowed to use the Tire Changer, that their training is verified through a testing program, and that all training is documented. All others, including children and untrained personnel, must be kept at least 30 feet away from the Tire Changer while it is in use.
- Make sure new employees are trained and supervised in the performance of their duties.
- Never perform any service on an *inflated* Tire; **always** fully deflate the Tire by removing the Valve Core and letting all air escape before beginning work.
- Never mount or change **damaged** Tires or Wheels.
- When mounting Tires, identify the maximum allowed inflation pressure; it should be on the sidewall of the Tire. **Do not exceed the maximum allowed inflation pressure of the Tire.**
- Make sure the Tire is restrained for inflation: either internally clamped, held down by the Restraint Cone (R76ATR only), or in a Tire Inflation Cage (such as the **RIC-4716 4-Bar Tire Inflation Cage from BendPak Ranger**). Do not inflate a Tire if it is *externally* clamped; external clamping interferes with inflation.
- When using the Tire Changer, be careful of your hands; there are multiple pinch point dangers on the unit. **Do not rest your hands on any part of the Tire Changer while using it.**

⚠ WARNING The Air Chuck has a self-gripping clip so you can clip it on when inflating a Tire, which means you do not have to hold it in place during inflation. **Do not hold the Air Chuck with your hand while you are inflating a Tire.** This leaves you very close to the Tire, which could result in injury if there were a problem during the inflation. Instead, clip the Air Chuck into position, move away from the Tire, then press and hold down the Inflation Foot Pedal.

- You **must** wear OSHA-approved (publication 3151) personal protective equipment at all times when installing, using, maintaining, or repairing the Tire Changer. Leather gloves, steel-toed work boots, eye protection, back belts, and hearing protection are **mandatory**.
- When using the Tire Changer, the operator must wear **ANSI-approved** eye protection at all times: safety glasses, a face shield, or protective goggles.

⚠ WARNING Always wear ANSI-approved eye protection. An accident could cause significant injuries to your eyes.

-
- The Tire Changer may work differently than other Tire Changers you have used. BendPak Ranger strongly recommends that all potential Operators practice using “non-customer” Tires to get familiar with how the product works **before** starting work on customer Tires.
 - Keep the work area clean and well lit. Dirty, cluttered, and dark work areas increase the chances of an accident happening.
 - Do not access the inside of the unit unless instructed to do so by BendPak Ranger Support.

 **WARNING** Be especially careful when inflating Tires. This is a dangerous time when using a Tire Changer. If the Tire and Wheel are mismatched or there is a defect in the Tire, it could explode, injuring or killing the Operator or bystanders. **Do not lean over the Tire when inflating a Tire.** Move away from the Tire during inflation.

- Do not use the Tire Changer in a wet environment or expose it to rain or excess moisture.
- If you need to use an extension cord to get power to the unit, use one with a current rating equal to or greater than that of the Tire Changer. Cords rated for less current than the Tire Changer could overheat. If used, arrange the extension cord so that it will not be tripped over or pulled out.
- Do not use anything flammable on the Beads or Rims as lubrication; instead, use non-flammable vegetable or soap-based lubricant.
- Do not use the Tire Changer in the vicinity of open containers of flammable liquids.
- Clean the unit according to the instructions under **Maintenance**.
- Read the entire *Installation and Operation Manual* **before** using the Tire Changer.
- Make a visual inspection of the Tire Changer **before each use**. Do not operate the Tire Changer if you find any issues. Instead, take it out of service, then contact your dealer, visit bendpak.com/support, or call BendPak Ranger at **(805) 933-9970**.

Turntable

The Turntable is where you place the wheel and tire for demounting or mounting.

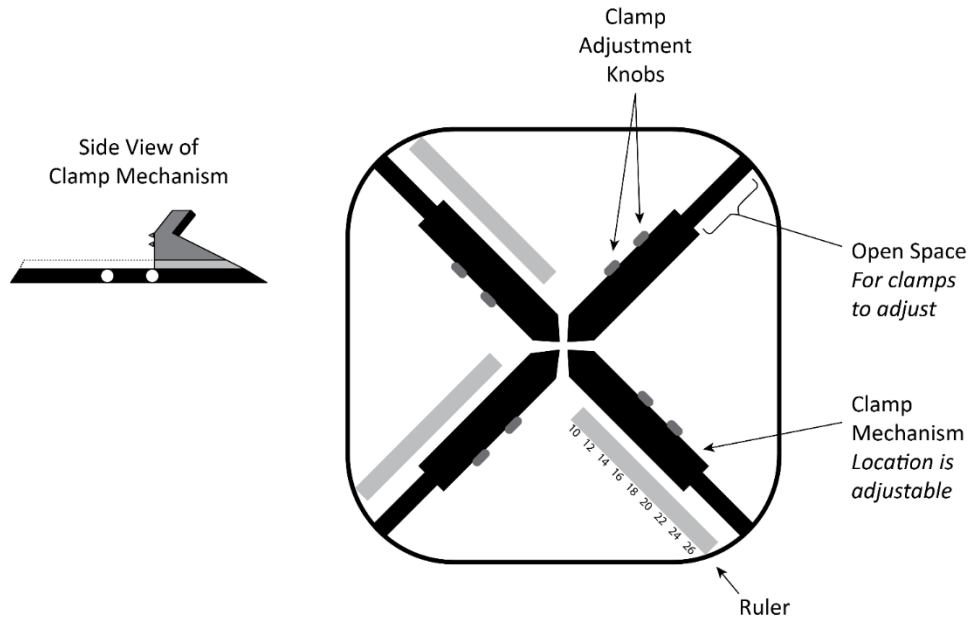

Side and top views. Not necessarily to scale. Not all components shown.

There are several important features to know about the Turntable:

- Flat, steel piece.** This is the actual Turntable. It holds the other components. Rotates both clockwise and counter-clockwise.
 - To rotate the Turntable clockwise:** Press **down** and hold down the Turntable Foot Pedal.
 - To rotate the Turntable counterclockwise:** Press **up** and hold the Turntable Foot Pedal.
- Clamp Mechanism.** Each Clamp mechanism includes a Clamp and two Clamp Adjustment Knobs. The Clamp Mechanism moves in and out to clamp Wheels either externally or internally. “External” and “Internal” clamping refer to the location of the Clamp in relation to the Wheel.

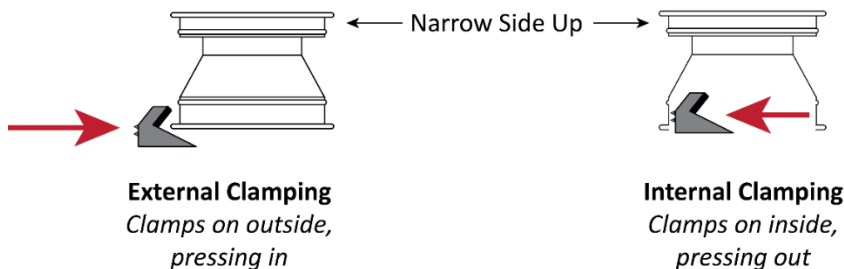

Side view. Some components exaggerated for clarity. Large arrows show direction Clamps are pressing. Only one of the four Clamps shown. Not necessarily to scale. Not all components shown.

As a general rule, clamp steel Wheels internally (Clamps push out against Wheel) and custom and mag Wheels externally (Clamps push in against outside Rim edge). Check with your Supervisor if you are unclear about which method to use for a particular set of Wheels.

To clamp externally. If necessary, use the Clamps Foot Pedal to move the Clamps all the way out (they may be all the way out already), put the Wheel between the Clamps, then press down on the Clamps Foot Pedal to move the Clamps in until the Wheel is being firmly held in place.

To clamp internally. If necessary, use the Clamps Foot Pedal to move the Clamps all the way in (they may be all the way in already), position the Wheel over the Clamps, then press down on the Clamps Foot Pedal to move the Clamps out until the Wheel is being firmly held in place.

Note: The Clamps Foot Pedal works as follows: If the Clamps are in the middle of the Turntable (all the way in), pressing down and then releasing the Clamps Foot Pedal moves them all the way out. If the Clamps are all the way out, pressing down and then releasing the Clamps Foot Pedal moves them all the way in.

- **Clamp Adjustment Knobs.** Move the Clamp between three different positions within the Clamp Mechanism to accommodate Wheels of different sizes.

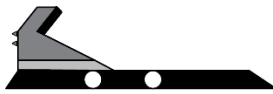

Clamp
outer position

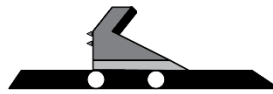

Clamp
center position

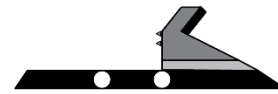

Clamp
inner position

To move a Clamp. Pull out and hold out the Clamp Adjustment Knob closest to the direction you want to move the Clamp, slide the Clamp in the desired direction, release the Clamp Adjustment Knob. If you want to move the Clamp again in the same direction, repeat the same procedure with the other Clamp Adjustment Knob.

If the Clamp is in the center position, you can only move the Clamp one position in either direction.

Pedals

The Tire Changer has multiple Foot Pedals:

- **Inflation Foot Pedal.** Supplies air through the Air Pressure Gauge Cord. Found on the left side of the Tire Changer. Press down and hold to inflate a Tire.
- **Tilt Back Foot Pedal.** Controls the Main Tower: moves it forwards or backwards. Press down and release to move the Main Tower back (if it is forward) or forward (if it is back).
- **Clamps Foot Pedal.** Moves the Clamps in or out. Press down and release to move the Clamps in (if they are out) or out (if they are in).
- **Bead Breaker Foot Pedal.** Press down and hold to move the Bead Breaker Blade in; Moves back out when you release.
- **Turntable Foot Pedal.** Rotates the Turntable. Press down and hold to move clockwise, press up and hold to move counter-clockwise.

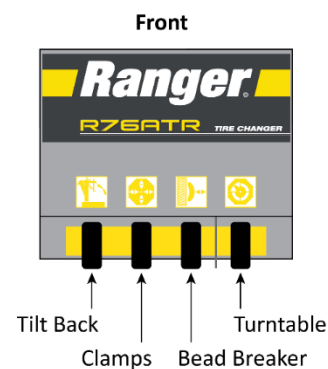
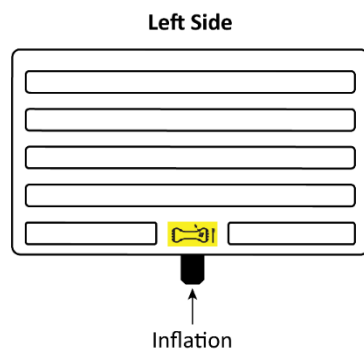

Side and top views. Not necessarily to scale.

Air Pressure Gauge

Components of the Air Pressure Gauge are:

- **Gauge.** Displays air pressure in the Tire to which the Air Chuck is attached.
- **Pressure Relief Button.** Exhausts air pressure when pushed.
- **Cord.** Extends and retracts to deliver Air Chuck to the Tire.
- **Air Chuck.** Attaches to the threads on the Valve Stem. Includes a self-gripping clip to allow holding Air Chuck in place during inflation.

⚠ WARNING ***Do not hold the Air Chuck while inflating a Tire.*** This leaves you close to the Tire, where injury may occur if there is a problem during inflation.

- **Threads.** Store the Air Chuck here using the self-gripping clip.

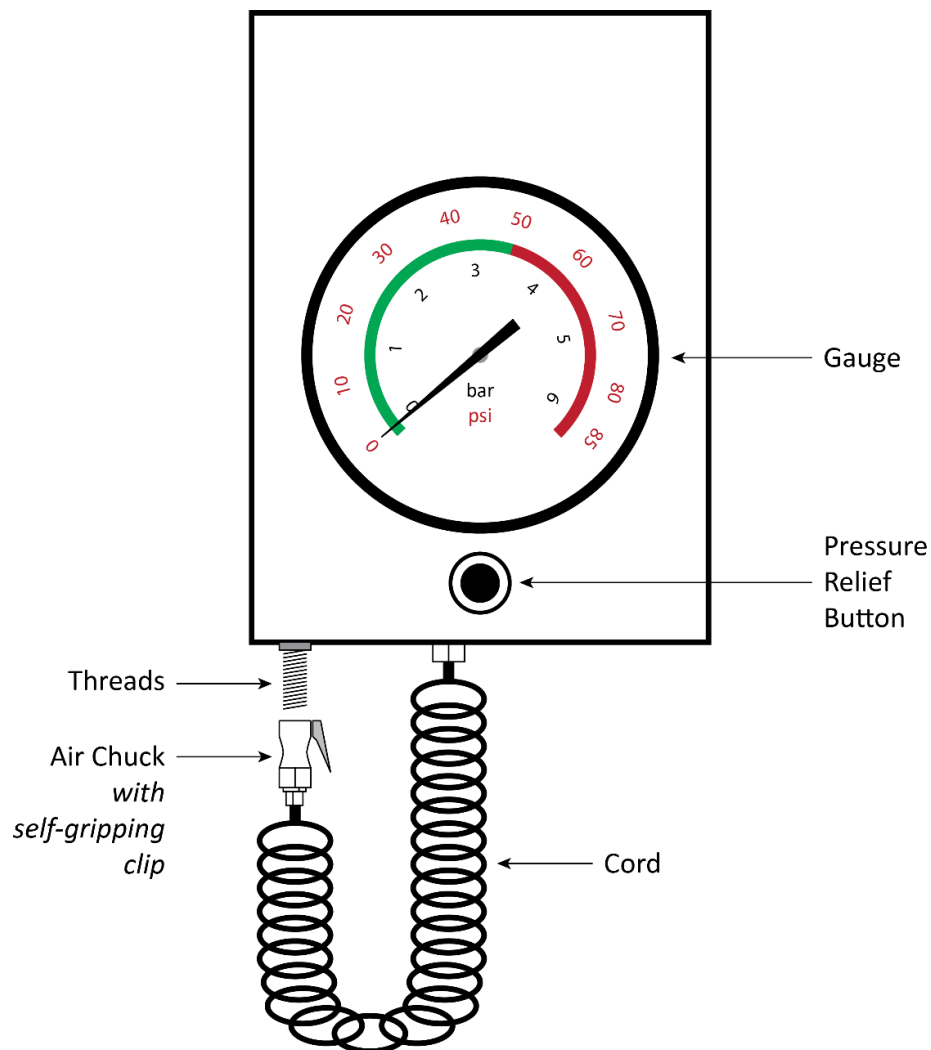

Front view. Not necessarily to scale. Not all components shown.

To view static pressure in a Tire: Attach the Air Chuck to the Tire; the Air Gauge shows the air pressure currently in the Tire. You do **not** need to press the Inflation Foot Pedal.

To see pressure during Tire inflation: Attach the Air Chuck, move away from the Tire, then press down the Inflation Foot Pedal. The Air Gauge shows the air pressure in the Tire as it inflates.

Main Tower

The Main Tower holds the main Tire Changer tool, the Mount/Demount Head. It tilts back out of the way when not in use.

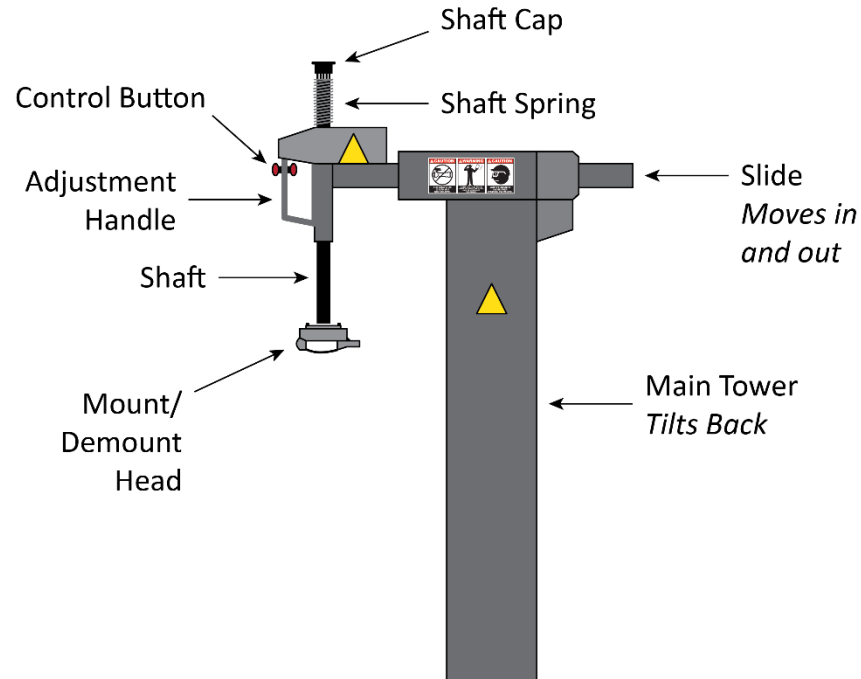

Side view. Not necessarily to scale. Not all components shown.

The primary parts of the Main Tower are:

- **Mount/Demount Head.** Attaches to the Bottom of the Shaft. The purpose of the Main Tower is to position the Mount/Demount Head to where it is needed.
- **Shaft.** Moves the Mount/Demount Head up and down.
- **Slide.** Moves the Mount/Demount Head in and out.
- **Control Button.** When pressed on the outside, locks the Shaft and Slide at their current positions. When pressed on the inside, unlocks the Shaft and Slide.
- **Shaft Cap.** Use it to move the Mount/Demount Head down. Do not grab the Shaft Spring or the part of the Shaft just above the Mount/Demount Head; they are not for controlling the Shaft height.
- **Shaft Spring.** Automatically pushes the Shaft back up when you unlock the Shaft using the Control Button.
- **Adjustment Handle.** Moves the Slide in and out.
- **Main Tower.** Tilts backwards and forwards. Controlled by the Tilt Back Foot Pedal. Press down and release on the Tilt Back Foot Pedal to move the Main Tower back (if it is forward) or forward (if it is back).

Mount/Demount Heads

The Mount/Demount Head is the main tool on the Tire Changer for demounting and mounting Tires. The Tire Changer comes with two Mount/Demount Heads:

- **Alloy Steel.** Silver in color. Includes plastic inserts on the inside to avoid damaging Rims. The following drawing shows the location of the Demount and Mount Lips.

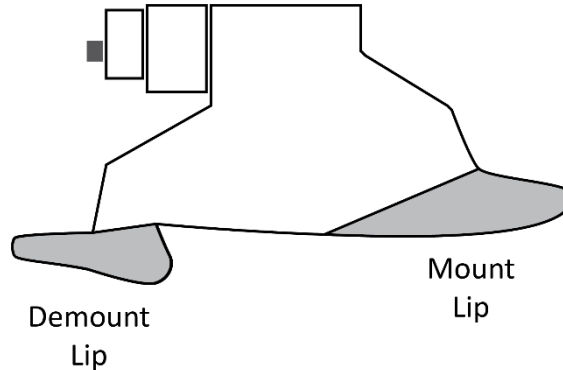

Side view. Set Screws on other side. Not necessarily to scale. Not all components shown.

- **Plastic Polymer.** Dark gray color. Non-marring surface will not scratch or otherwise damage paint or powder coating on Wheels.

The following drawing shows the location of the Demount and Mount Lips. It also shows where the Tire Bead goes during demounting and mounting.

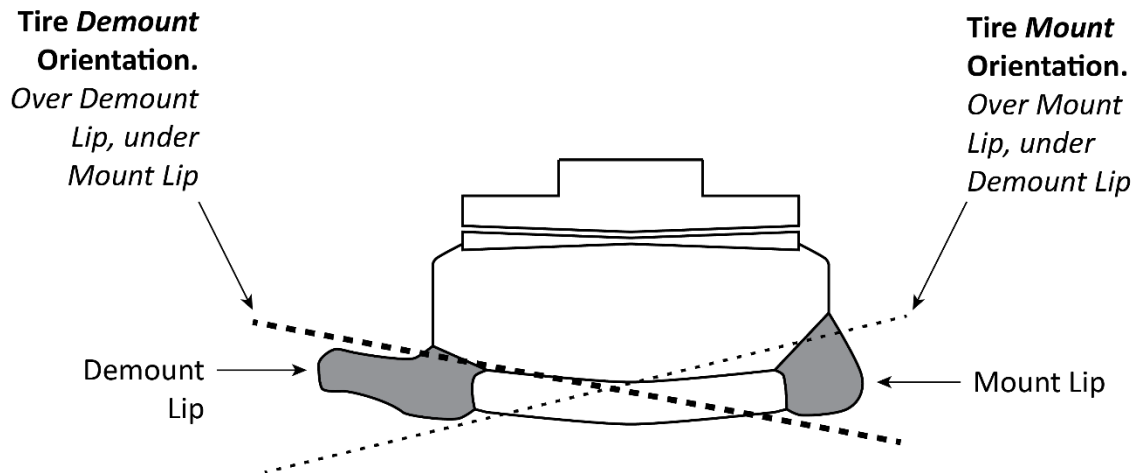

Side view. Set Screws on other side. Not necessarily to scale. Not all components shown.

The Demount Lip and Mount Lip work as follows:

- **During demounting.** The Tire Bead goes **over the Demount Lip** and under the *Mount Lip*.
- **During mounting.** The Tire Bead goes **over the Mount Lip** and under the *Demount Lip*.

You can easily switch between the two Mount/Demount Heads using the two Set Screws and a 6 mm hex wrench. Loosen the Set Screws, slide the Head down and off, replace it with the other one, and then tighten the Set Screws.

Note: The Alloy Steel Mount/Demount Head includes an additional installation bolt that installs from underneath.

Bead Breaker

Use the Bead Breaker to separate the Beads of the Tires from the rims.

Remember that the Beads of a Tire must be broken on **both sides** of the Tire.

⚠ WARNING **Do not break the Beads of a Tire until you are certain the Tire is fully deflated.** Breaking the Bead of a Tire with air still in it could injure you or others nearby. The best way to be sure the Tire is fully deflated is to remove the Valve Core and wait for all of the air to come out.

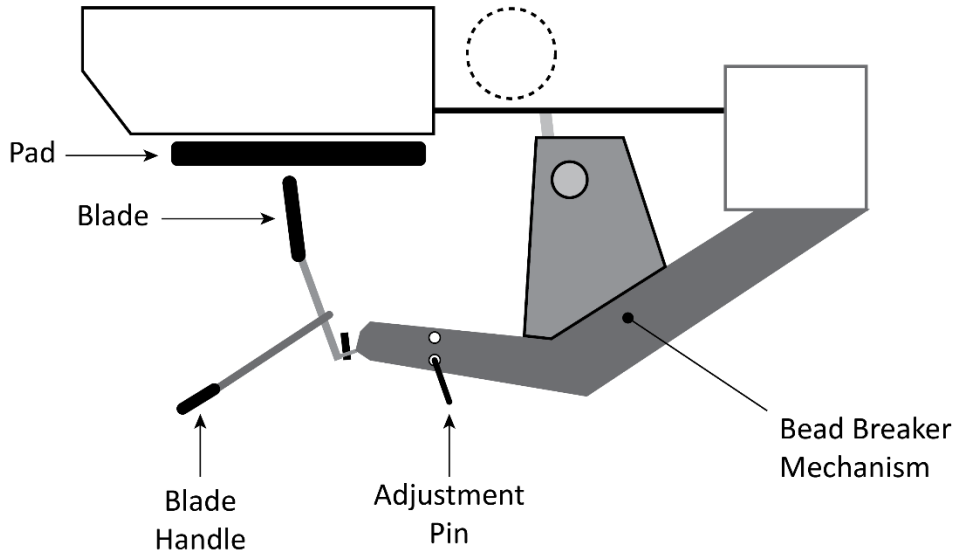

Top view. Not necessarily to scale. Not all components shown.

⚠ WARNING **There is a risk of crushing with the Bead Breaker.** Do not hold onto the Blade Handle when the Bead Breaker is moving. After positioning the Bead Breaker Blade, move away from the Bead Breaker, and make sure the area is completely clear **before** pressing the Bead Breaker Foot Pedal.

The main components of the Bead Breaker are:

- **Bead Breaker Mechanism.** Moves in and out under the control of the Bead Breaker Foot Pedal. Moves with great force; make sure you are completely clear of the Blade and the Bead Breaker Mechanism **before** pressing the Bead Breaker Foot Pedal.
- **Blade.** The part of the Bead Breaker that contacts the Tire and actually breaks the Bead.
- **Blade Handle.** Controls the Blade, moving it side to side and in and out.
- **Pad.** The side of the Tire whose Bead is **not** being broken goes up against the Pad.
- **Adjustment Pin.** Allows you to accommodate Tires of different sizes by controlling the location of the Blade.

To use the Adjustment Pin: remove it from its current location, then slide it into the other location.

Bead Lifting Tool

Use the Bead Lifting Tool to pull the Tire's Bead up and over the Mount/Demount Tool to help demount the Tire.

You can also use the Bead Lifting Tool to push down the Tire's Bead — to the left of the Mount/Demount Head — during the mounting of a Tire.

The Bead Lifting Tool has an angled and a hooked end. You can use either end.



Turbo-Blast™ Bead Sealing System

The Turbo-Blast Bead Sealing System, located on the back of the Tire Changer, provides a very strong burst of pressurized air to aid sealing a stubborn bead.

The system includes:

- **Pressurized Air Tank.** Holds the pressurized air, enough for multiple blasts of pressurized air.
- **Intake Lever.** When open, air from the incoming air source goes into the Pressurized Air Tank. When closed, no air can get into the tank.
- **Pressure Relief Valve.** Releases air pressure from the tank if the pressure gets too high.
- **Hose.** Moves the pressurized air from the tank to the Nozzle.
- **Nozzle.** Where the pressurized air comes out.

⚠ DANGER Use extreme care with the TurboBlast Bead Sealing System. You could cause product damage, personal injury, or death. Never point the Nozzle at a person or thing. Do not use the TurboBlast System for anything except sealing a bead.

- **Handle.** Gives you an easy way to position the Nozzle. **Use both hands.**
- **Button.** Press to release a powerful blast of air.

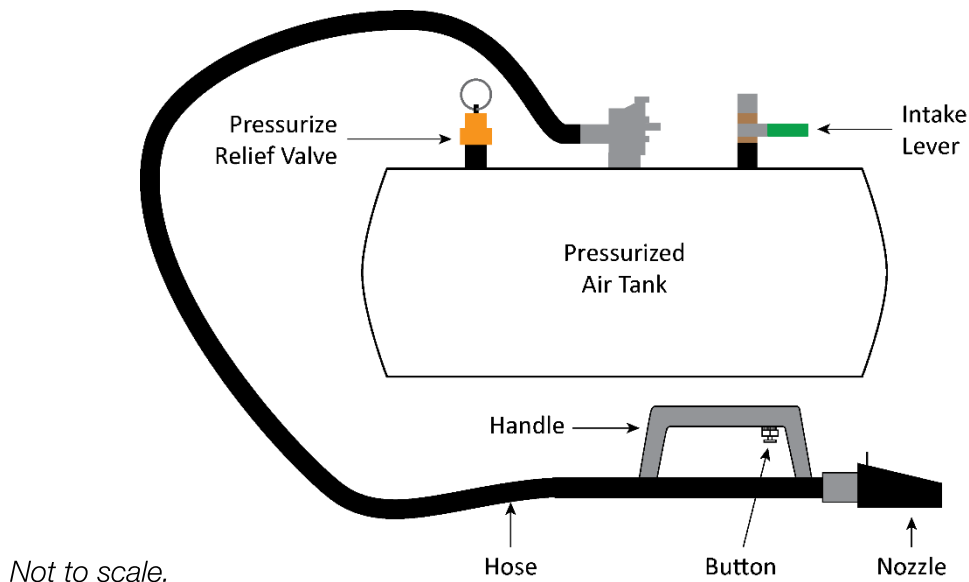

Assist Tower (R76ATR Only)

The Assist Tower holds Tools designed to aid dismounting, mounting, and inflating.

The two Assist Tower Arms move up and down as *one*, but move side to side **independently**.

The components of the Assist Tower are:

- **Controls.** Moves the two Assist Tower Arms up and down together.
- **Bead Roller.** Holds the top Bead during mounting.
- **Upper Assist Arm.** Holds two Tools and the Controls.

The two Tools are:

- *Restraint Cone.* Used in two ways. First, when mounting a Tire, use the Restraint Cone to push the Tire down (aids clamping a Wheel externally). Second, when inflating a Tire, use to hold the Wheel in position on the Turntable.
- *Assist Tool.* Used to hold down the top Bead during mounting. Travels with the Tire.
- **Lower Assist Arm.** Holds a single Tool:
 - *Helper Disc.* Used to hold up the bottom Bead during demounting.

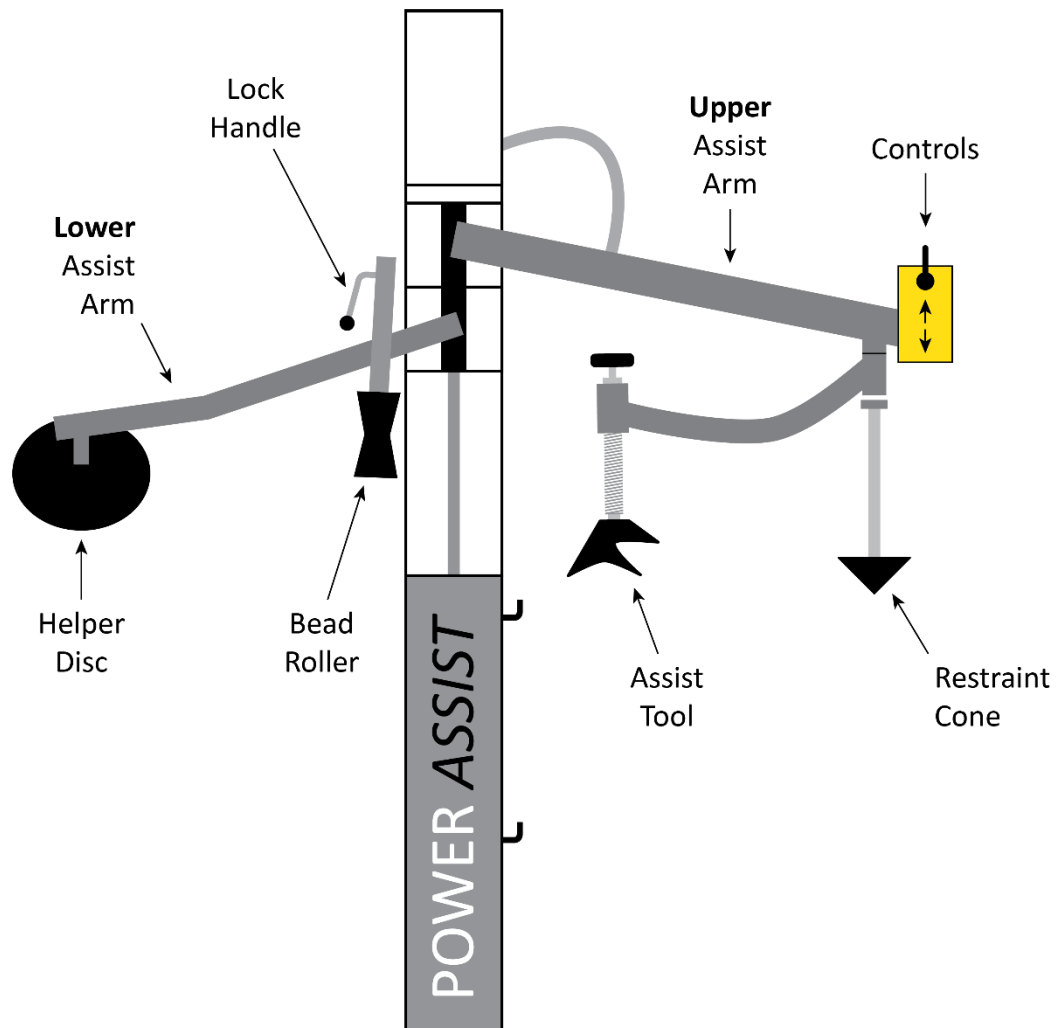

Front view. Not necessarily to scale. Not all components shown.

Before You Change a Tire

⚠ DANGER Do not use the Tire Changer unless you have been properly trained and have read the entire *Installation and Operation Manual*. Tire changing must only be done by trained, authorized, and supervised personnel. **Failure to understand and follow proper procedures may result in injury or death.**

Before you change a Tire, remember to:

- **Remove weights.** Check the Wheel to make sure that all clip-on or adhesive weights have been removed.
- **Deflate the Tire.** Remember to **fully deflate Tires before demounting.**
To make sure a Tire is *fully deflated*, remove the Valve Core from the Valve Stem and then wait for all of the air to exit.
- **Have Tire Lubricant ready.** Tire Lubricant makes the process of demounting and mounting Tires much easier. If you do not use Tire Lubricant, you significantly increase the chances of damaging the Wheel and the Tire. Tire Lubricant is not provided with the Tire Changer.
- **Check for damage.** Especially with expensive Wheels, make sure to check for any damage **before** changing the Tire. Additionally, damaged Wheels and Tires are dangerous to work with.
- **Understand Performance Wheels.** Before servicing performance Wheels, review the Performance Wheels section of this manual and your shop's policies for them.
- **Identify the Narrow Side/Drop Center of the Wheel.** The rule is: the Narrow Side/Drop Center side of the Wheel gets put onto the Tire Changer facing **up**. For most Wheels, this means the side of the Wheel facing the *outside* of the Vehicle goes on top, because that's where the Narrow Side/Drop Center side is on most (but not all) Wheels.

The following drawing shows two Wheels and identifies the Narrow Side, Drop Center, and Wide Side of each.

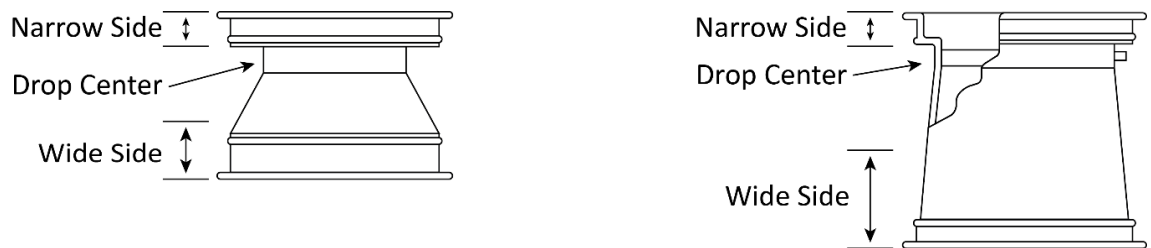

Some aftermarket and OEM performance Wheels are **reverse** drop-center Wheels. This means the Narrow Side/Drop Center side of the Wheel is the side closer to the *inside* of the Vehicle. The rule still holds for these Vehicles: the Narrow Side/Drop Center side of the Wheel is put onto the Tire Changer facing up.

- **Ask your Supervisor.** If you have concerns about a Tire, consult with your Supervisor **before** starting work.

Working with Custom and Special Wheels

This section covers working with Alloy Wheels with no drop center, European performance Wheels, and Wheels with tire pressure monitoring systems.

Alloy Wheels

Some manufacturers offer Wheels with little or no drop center. These types of Wheels are almost never Department of Transportation approved.

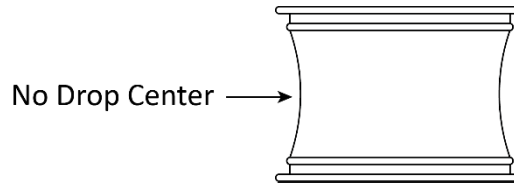

⚠ DANGER The Tire, Wheel, or both can be damaged, and the Tire could explode under pressure, resulting in serious injury or death. ***BendPak Ranger recommends you not try to demount or mount this type of Wheel.*** If you do attempt to demount or mount this type of Wheel, **proceed with extreme caution.**

European Performance Wheels

Some European performance Wheels have very large humps, except near the Valve Hole.

On these Wheels, the Beads should be broken at the Valve Hole on both the upper and lower sides first.

Wheels with Tire Pressure Monitoring Systems (TPMS)

Some Wheels have a pressure sensor located behind the Valve Stem. On these Wheels, the Beads should be loosened opposite the Valve Stem on both upper and lower sides first, before breaking the Beads on the rest of the Tire.

Performance Wheels on some Vehicles (including Corvette, BMW, and Lamborghini Diablo) have a pressure sensor strapped to the Wheel *opposite* the Valve Stem. On these Wheels, the Beads should be loosened at the Valve Stem on both sides first, before breaking the Beads on the rest of the Tire.

Be mindful of the TPMS sensor when breaking a Tire's Bead, demounting a Tire, and mounting a new Tire. If your shop does not have specific recommendations for handling these situations, BendPak Ranger recommends:

- **When breaking a Tire's Bead.** Keep the TPMS sensor away from where the Bead is being broken. Put the sensor at 12 o'clock high (relative to the ground) when breaking the Bead.
- **When demounting a Tire.** Put the TPMS sensor just to the right of the Mount/Demount Head.
- **When mounting a Tire.** Put the TPMS sensor just to the left of the Mount/Demount Head.

These are general guidelines; be sure to use common sense and take into consideration the specifics of each situation. If you still have concerns, speak to your Supervisor.

Important: When you are finished mounting a Tire with a TPMS sensor, make sure it is working. It is against the law to ***knowingly not*** re-install a working TPMS if the Vehicle arrived at the facility with a functioning TPMS.

The Steps in Changing a Tire

Before you start working on a Tire, review the requirements in [Before You Change a Tire](#).

Changing a Tire consists of multiple steps:

1. **Deflate the Tire.** There is a large amount of energy (air pressure) stored in a Tire when it is inflated. You **must fully** deflate the Tire before you can demount it. If you do not, that energy will be released when you try to demount it, which could result in the Tire exploding, causing property damage, injury and even death to the Operator or bystanders. **Never work on a Tire unless you have personally confirmed that it is fully deflated.** The best way to do this is to make sure the Valve Core has been removed from the Valve Stem, which lets the air out.
2. **Break the Bead.** Tires stay in position because the Tire Bead is seated between the Bead Retainer and the Rim Lip of the Wheel (called the Bead Seat). To demount a Tire, you must get the Bead out of the Bead Seat all the way around both sides of the Tire. This is called Breaking the Bead. Use care when Breaking the Bead of Wheels with a TPMS.

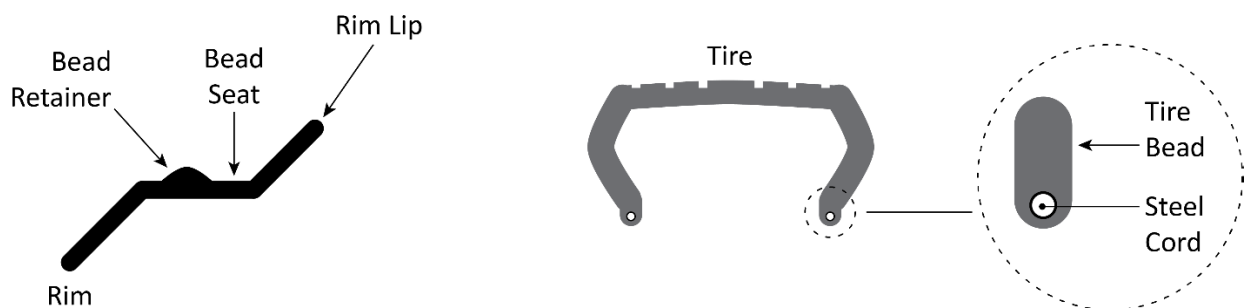

3. **Secure the Wheel on the Turntable.** It is important for the Wheel to stay in place on the Turntable. The Tire Changer supports both Internal and External Clamping.
4. **Demount the Tire.** Once the Bead is broken, you still have to slide both Beads of the Tire over the top Rim of the Wheel to get the Tire fully off. Once the Tire is demounted from the Wheel, you can move it out of the way and then mount the new Tire.
5. **Mount the new Tire.** Mounting a Tire is basically the opposite of demounting. You first need to get the Beads under the Rim (the opposite of demounting the Tire), get the Beads into position **in** the Bead Seats (the opposite of Breaking the Bead), and then inflate the Tire (the opposite of deflating the Tire).
6. **Inflate the Tire.** Three separate stages: Bead Seal, Bead Seat, Inflate. **Bead Sealing** is putting in a small amount of air pressure to push the Tire up against the Rim so that no more air leaks out. **Bead Seating** is putting in more air pressure to “pop” the Beads into position in the Bead Seats. **Inflation** is adding air pressure to the Tire manufacturer’s recommended pressure after the Beads have been seated.

Depending on how much air pressure was needed to seat the Bead, you may have to release some air **out** of the Tire to get to the recommended pressure for the Tire.

7. **Remove the Wheel from the Turntable.** Disengage the Clamps, then move the Wheel and Tire off the Turntable.

About Valve Stems

The following drawing shows a Valve Stem and its components.

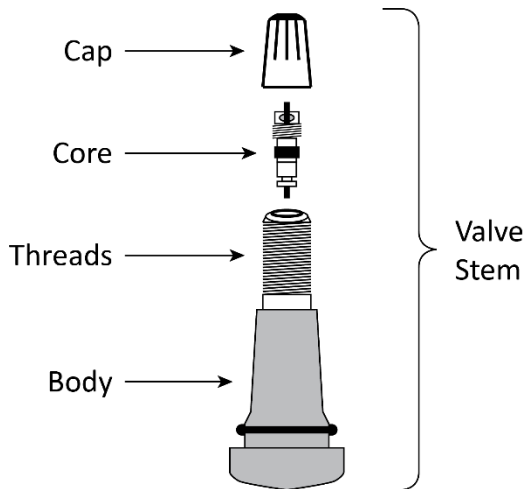

This section talks about Valve Cores and Valve Stems at multiple points:

- **When demounting a Tire.** Removing the Valve Core lets air out of the Tire, which **must** be done before you can demount a Tire.
A Valve Core Tool allows easy removal of a Valve Core.
- **When replacing the entire Valve Stem.** Valve Stems are normally replaced when you mount a **new** Tire on a Wheel.

When mounting a new Tire, BendPak Ranger recommends installing a new Valve Stem, but it is not required. The process for replacing a Valve Stem is to cut out or pull out the old Valve Stem, then install the new Valve Stem. This should be done after the old Tire has been demounted but before the new Tire is mounted.

- **When inflating a Tire.** Before starting the first stage of inflating a Tire (sealing the Beads), remove the Valve Core and set it aside. Removing the Valve Core allows air to move more easily into the Tire.
Once the *second* stage of inflating a Tire (seating the Beads) is *complete*, put the Valve Core back in.

When, sealing and seating the Beads, do not put too much air pressure into the Tires. Inflating the Tire, the third stage, does. So, you want the Valve Core in for the inflation stage, as that will keep the air from coming back out of the Tire.

If you forget to put the Valve Core back in before inflating the Tire, you can put it back in when the Tire is inflated. Just note that when you unclip the Air Chuck, the air is going to start coming out of the Tire, which both lowers the pressure in the Tire and makes it difficult to put the Valve Core in.

Deflate the Tire

You must **fully deflate** a Tire before you can demount it.

To deflate a Tire:

1. If the Valve Stem has a Cap on it, remove it.
2. Unscrew the Valve Core from inside the Valve Stem.

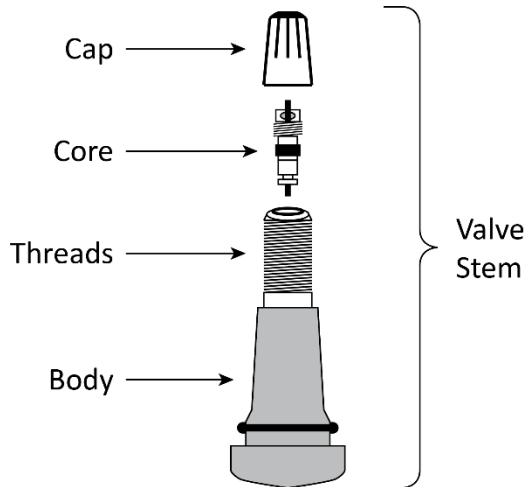

Use a Valve Core Tool to remove the Valve Core. If a tool is not available, you may be able to use very small needle-nosed pliers.

If you are going to use the same Valve Stem with the new Tire you are going to mount, remember to keep the Valve Core.

BendPak Ranger recommends installing a new Valve Stem when you mount a new Tire.

3. Make sure all of the air comes out of the Tire.

⚠ WARNING Do not proceed with any other Tire changing activity until you are certain the Tire is **fully** deflated. Do not demount a Tire until you have made sure the Tire is fully deflated. When demounting a Tire, make sure it is **fully** deflated.

Break the Beads

The Beads must be broken (pushed out of their Bead Seats) – on both sides of a Tire – **before** the Tire can be demounted.

The Bead is broken when the Tire Beads come out from between the Rim Lip and the Bead Retainer (the Bead Seat) all the way around the Tire, on **both sides** of the Tire.

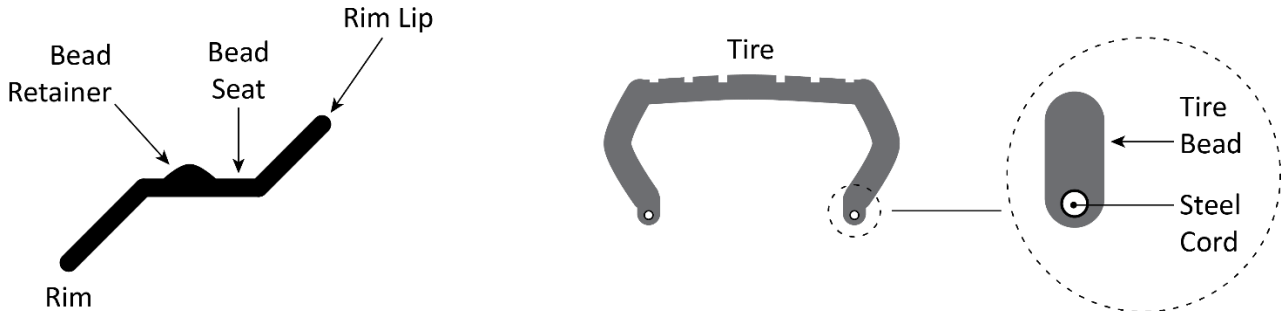

To break a Tire's Beads:

1. Make sure you are wearing OSHA-approved (publication 3151) personal protective equipment: leather gloves, steel-toed work boots, back belts, hearing protection, and ANSI-approved eye protection (safety glasses, face shield, or goggles).
2. Check the Tire again to make sure it is **fully** deflated.
3. Check both sides of the Tire to make sure all Wheel weights (from balancing) have been removed. If they have not, remove them.

⚠ CAUTION Breaking the Beads of a Tire with Wheel weights could damage the Tire Changer and/or the Wheel.

4. Identify the Narrow side of the Tire whose Beads you are breaking; *break the Narrow side first*.
5. Move the Tire into position between the Pads and the Bead Breaker Blade, with the Narrow side of the Tire on the Blade side.
6. Depending on the size of the Tire whose Bead you are breaking, you may need to adjust the position of the Blade using the Adjustment Pin.

Refer to **Bead Breaker** for more information.

7. If you are Breaking the Beads of a Tire with a TPMS, put the sensor at 12 o'clock high or 6 o'clock low (relative to the ground), to reduce the chances of damaging it.

Note that your shop may have different policies for handling Tires with a TPMS.

-
8. Move the Blade so that it is on the side of the Tire, very close to, **but not touching**, the Rim.



⚠ CAUTION Make sure the Blade is **not** touching the Rim. The Bead Breaker Mechanism uses a great deal of force; you will damage the Rim if the Blade pushes on it instead of on the side of the Tire.

9. Step on and hold down the Bead Breaker Foot Pedal.

The Blade pushes in, moving the Bead out of the Bead Seat and in towards the Drop Center of the Tire.

When the Bead breaks, it frequently (but not always) makes an audible popping sound.

10. When the Blade cannot go any further in, release the Bead Breaker Foot Pedal.

11. If the Blade does not fully move the Bead out of the Bead Seat, adjust the Blade a little bit one way or the other and then try again.

12. When the Bead is broken at the first spot, rotate the Tire 180° and break the Bead at that location.

Every Tire is different. With some Tires, the entire Bead on one side could be broken with the first use of the Bead Breaker Blade. Other Tires could take multiple attempts until the Bead is broken all of the way around the Tire.

13. When the Bead is completely broken all the way around on one side of the Tire, move the Tire out, turn it around, and then break the Bead on the second side of the Tire.

Again, avoid breaking the Bead at the TPMS; you could damage the sensor.

Important: It may take you two or three times to break the Bead at any one spot. Nevertheless, keep going until you break the Bead all the way around the Tire and on both sides of the Tire. ***Do not proceed to demounting the Tire until the Bead is broken all the way around and on both sides of the Tire.***

Secure the Wheel on the Turntable

Before you can demount a Tire, you must secure the Wheel on the Turntable. The Tire Changer supports two ways of securing the Wheel to the Turntable:

- **External clamping.** The Clamps are on the outside, pressing inwards.
- **Internal clamping.** The Clamps are on the inside, pressing outwards.

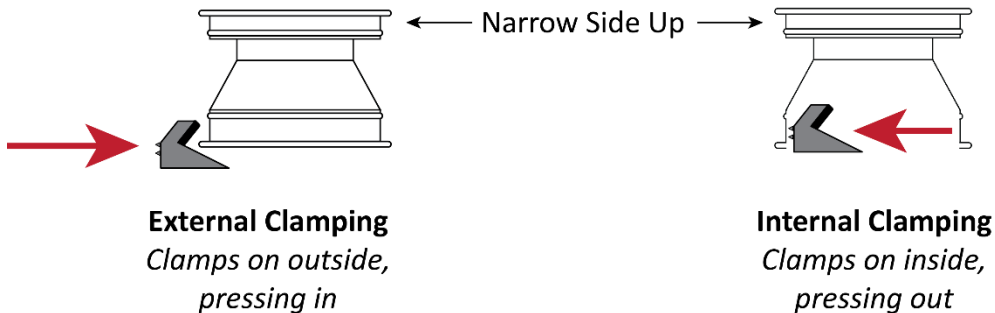

As a general rule, steel Wheels clamp internally, and custom and mag Wheels clamp externally. Check with your Supervisor if you are unclear about which method to use.

To secure a Wheel on the Turntable:

1. Make sure you are wearing OSHA-approved (publication 3151) personal protective equipment: leather gloves, steel-toed work boots, back belts, hearing protection, and ANSI-approved eye protection (safety glasses, face shield, or goggles).
2. Identify the Narrow side of the Tire; this side goes up.
3. Determine which clamping method you are going to use and move the Clamps to the starting position for that clamping method:
 - If you are clamping **externally**, move the Clamps all the way **out**.
 - If you are clamping **internally**, move the Clamps all the way **in**.
4. Put the Wheel onto the Turntable, either between the Clamps that are all the way out for external clamping or over the Clamps that are all the way in for internal clamping.
5. Secure the Wheel by pressing down and then releasing the Clamps Foot Pedal.



Tip

Clamping externally can be difficult on some Tires. If you are having problems getting the Clamps to clamp externally, either press down on the Wheel from above or, if you are using the R76ATR, use the Restraint Cone to push the Wheel down from above. Pushing down from above moves the Rim away from the Tire a little, making it easier for the Clamps to grab the Rim.

6. Check to make sure the Wheel is securely clamped.

Demount the Tire

Demounting a Tire is the process of taking a Tire off a Wheel. Specifically, you need to pull the top Bead over the **top** of the Rim, then pull the bottom Bead also over the **top** of the Rim.

⚠ CAUTION You **must** use Tire Lubricant; this helps the Tire demount more easily and helps to prevent damage to the Wheel and/or the Tire.

During demounting, the Bead goes over the Demount Lip of the Mount/Demount Head but stays under the Mount Lip. See **Mount/Demount Heads** for additional information.

⚠ WARNING The following procedure **requires** that the Tire's Beads are broken on **both** sides. **Do not** try to demount a Tire whose Beads are not broken on both sides; you could damage the Wheel, the Tire, or even injure yourself or bystanders.

To demount a Tire:

1. Make sure you are wearing OSHA-approved (publication 3151) personal protective equipment: leather gloves, steel-toed work boots, back belts, hearing protection, and ANSI-approved eye protection (safety glasses, face shield, or goggles).
2. Verify that the Tire's Beads are completely broken on **both sides** of the Tire.
3. Apply Tire Lubricant to the Tire Beads and the top Rim.
This helps the Beads slide over the Rims more easily.
4. Move the Mount/Demount Head into position, very close to the Rim **but not touching it**, and lock it in position using the Control Button on the Adjustment Handle.
5. Push the top Bead on the side of the Tire *opposite* the Mount/Demount Head into the Drop Center of the Wheel.

This gives you some extra room to help pull the top Bead over the Demount Lip.

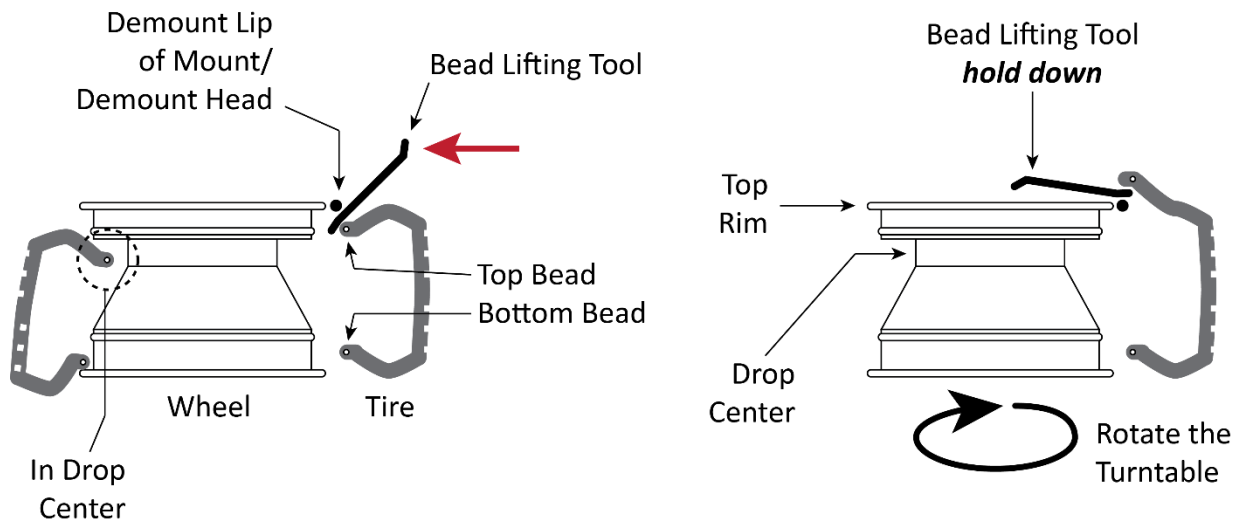

Tires not shown for clarity. Side view. Not necessarily to scale.

6. Take the Bead Lifting Tool, position one end on the outside of the Demount Lip of the Mount/Demount Head, then slide it down between the Demount Lip and the top Tire Bead until it is just past (and a little under) the Bead.
7. Carefully push the Bead Lifting Tool in towards the middle of the Wheel in an arc.

This pulls the top Bead over the Demount Lip, which is what you want.

Top Bead Demount Orientation.

*Top Bead over Demount Lip,
under Mount Lip*

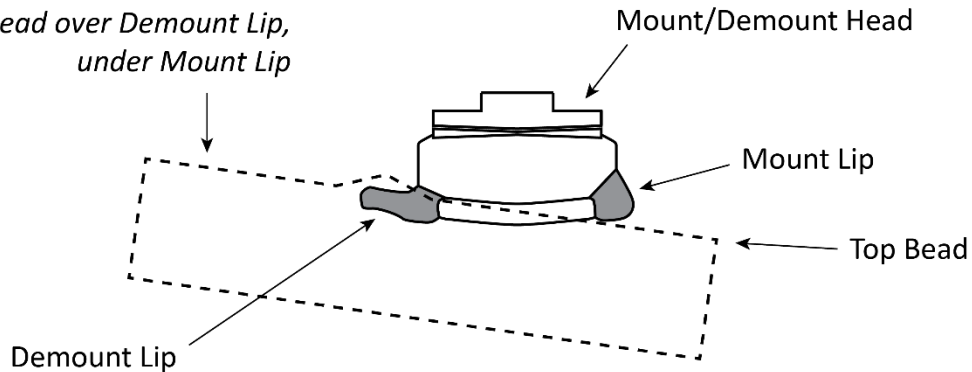

⚠ CAUTION **Hold on to the Bead Lifting Tool.** Depending on the Tire, it may take a good deal of force to move the Bead up and over the Demount Lip. If you were to release the Bead Lifting Tool at this point, it could easily injure the Operator or damage the Wheel, Tire, or the Tire Changer.

Check to make sure the Bead Lifting Tool is lifting the Tire Bead up and over the Demount Lip of the Mount/Demount Head. If the Tire Bead is **not** coming up and over the Demount Lip, pull the Bead Lifting Tool out and start again. *On some Tires, it may take multiple attempts.*

8. When the Bead Lifting Tool has moved all the way over to the middle of the Wheel, check the top Bead to make sure it is above the Demount Lip.

The top Bead **must** be above the top of the Demount Lip to proceed.

Continue holding the Bead Lifting Tool.

9. Press down and hold down the Turntable Foot Pedal; the Turntable begins turning clockwise.

Note: If you have difficulty getting the Turntable to move clockwise, release the Turntable Foot Pedal, keep hold of the Bead Lifting Tool, and then press up on the Turntable Foot Pedal for few seconds to move the Turntable counterclockwise, then press down again to move clockwise. Repeat as necessary to clear up the difficulty.

Watch the top Bead to make sure it is being pushed over the Rim, all the way around the Tire, as the Turntable moves.

10. Keep turning the Turntable until the entire top Bead pops over the top of the Rim.
11. When the top Tire Bead pops over the Rim, release the Turntable Foot Pedal and remove the Bead Lifting Tool.

The top Bead is demounted.

The next step is to demount the bottom Bead over the top Rim.

12. Make sure there is still lubricant on the bottom Bead and the top Rim.

If there is not, put some more on.

13. Push the bottom Bead up as much as possible all the way around the Wheel, then push the side of the Tire opposite the Mount/Demount Head into the Drop Center of the Wheel.

If you are using the R76ATR, you can position the Helper Disc to help hold up the Tire. If you are using the R76LT, you can manually lift the Tire.

14. Take the Bead Lifting Tool, put it on the outside of the Demount Lip, then slide it down past and under the bottom Bead.

Getting the Bead Lifting Tool into position may be trickier this time, as the rest of the Tire could be in the way as you are trying to get access to the bottom Bead.

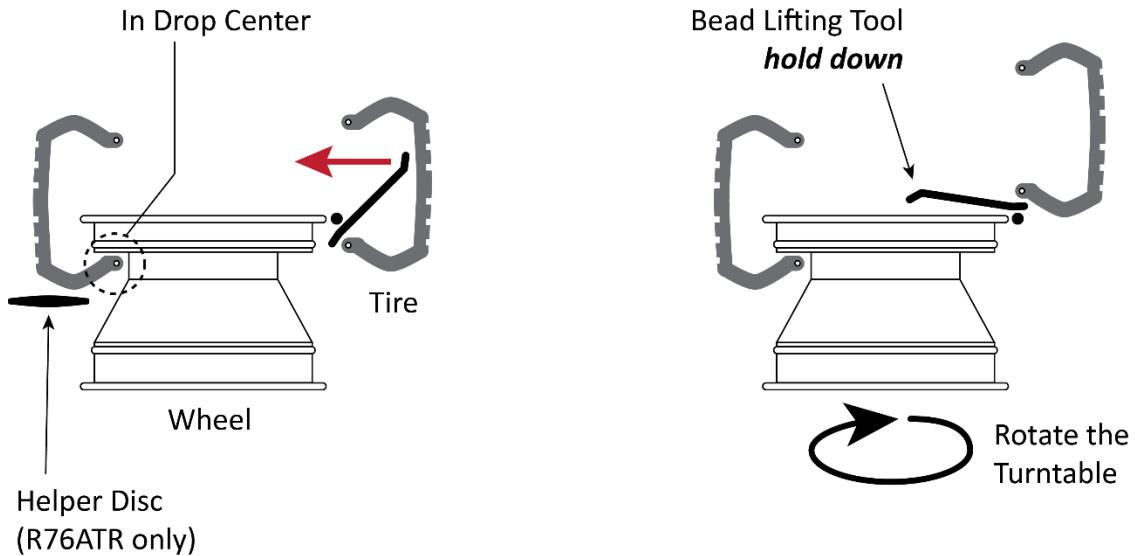

Tires not shown for clarity. Side view. Not necessarily to scale. Helper Disc location is adjustable.

15. Push the Bead Lifting Tool towards the middle of the Wheel in an arc, pulling the bottom Bead over the Demount Lip of the Mount/Demount Head.
16. While continuing to hold the Bead Lifting Tool, press down and hold down the Turntable Foot Pedal to move the Turntable clockwise.
Watch the bottom Bead to make sure it is being pushed over the top of the Rim as the Turntable moves.
17. Keep turning the Turntable until the entire bottom Bead moves over the top Rim.
The Tire is now dismounted and can be removed.

Wheel / Tire Mismatches

A Wheel / Tire mismatch is mounting a Tire where the Tire's Bead diameter does not **exactly** match the Diameter of the Wheel.

⚠ DANGER **A Wheel / Tire mismatch is extremely dangerous.** A mismatched Tire and Wheel may separate or explode, resulting in injury or even death.

The differences can be subtle, so you must take care to get an **exact match**.

⚠ WARNING **Do not** mount a Tire on a Wheel until you, have positively identified and correctly matched the Tire and Rim diameters. If you try to seat a Tire Bead on a mismatched Wheel and Tire by inflating it, the Tire Bead may break with explosive force, which could result in serious injury or death.

Mount a New Tire

Mounting a Tire is the process of putting a Tire onto a Wheel.

⚠ WARNING Mounting a Tire can be hazardous if not done correctly. Do not mount a Tire unless you have been trained to do so. Failure to understand and follow proper procedures can result in injury or death.

During mounting, the Tire Bead goes over the Mount Lip of the Mount/Demount Head, but stays under the Demount Lip. See **Mount/Demount Heads** for additional information.

Review the following points **before** mounting a Tire:

- Check the Tire and Wheel to make sure they are a match.
- Install a new Valve Stem before mounting the Tire.
- Make sure the Wheel is both clean (bead seating area) and free of previous balancing weights. Remove any weights and any corrosion you find on the Wheel; **do not** service heavily corroded Wheels.
- Check the Tire for damage and excessive age; **do not mount a damaged Tire**.
- Check the location of the TPMS and adjust the Tire if necessary. Do not damage the sensor.
- Check for yellow and red dots. If found, line them up with the appropriate locations on the Tire.
- Make sure the Tire is **fully** deflated.

When mounting a Tire, mount the bottom Bead first (over the top of the Rim), then the top Bead (also over the top of the Rim).

To mount a Tire:

1. Make sure you are wearing OSHA-approved (publication 3151) personal protective equipment: leather gloves, steel-toed work boots, back belts, hearing protection, and ANSI-approved eye protection (safety glasses, face shield, or goggles).
2. If the Wheel is not already secured on the Turntable with the Narrow Side facing up, move the Wheel onto the Turntable and secure it internally or externally.
3. Apply Tire Lubricant to the top and bottom Beads and the top Rim.
4. Put the Tire over the Wheel, with the side that will be next to the Mount/Demount Head low and the other side high (above the top of the Wheel).
5. Move the Mount/Demount Head into position.
6. Bring up the low side of the Tire and put the **bottom** Tire Bead over the Mount Lip and under the Demount Lip.

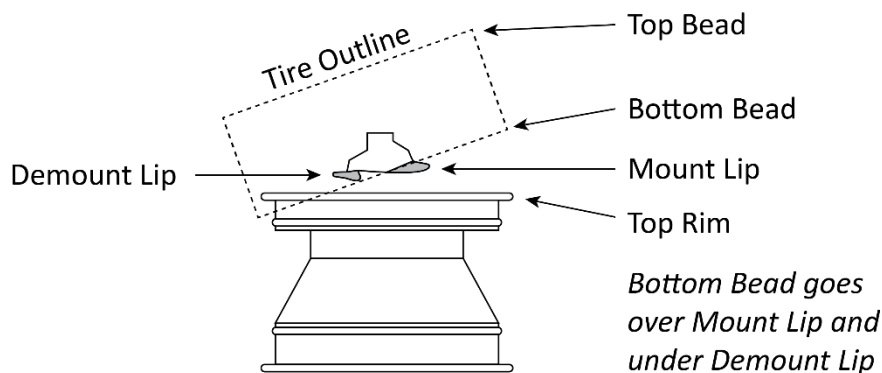

Side view. Not necessarily to scale.

7. Push the side of the Tire farthest away from the Mount/Demount Head down over that side of the Rim and Wheel as far as it will go.
8. Press down on and hold down the Turntable Foot Pedal.
The Turntable will turn clockwise, and the bottom Tire Bead will drop over the top of the Rim.
9. Put the **top** Tire Bead over the Mount Lip and under the Demount Lip.

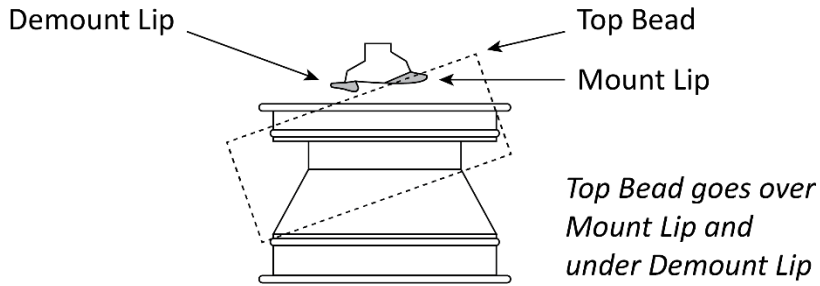

Side view. Not necessarily to scale.

10. If using the R76LT, position the Bead Lifting Tool to the left of the Mount/Demount Head (about 20 percent of the distance around the Tire), with the Bead Lifting Tool pushing down on the Sidewall of the Tire.

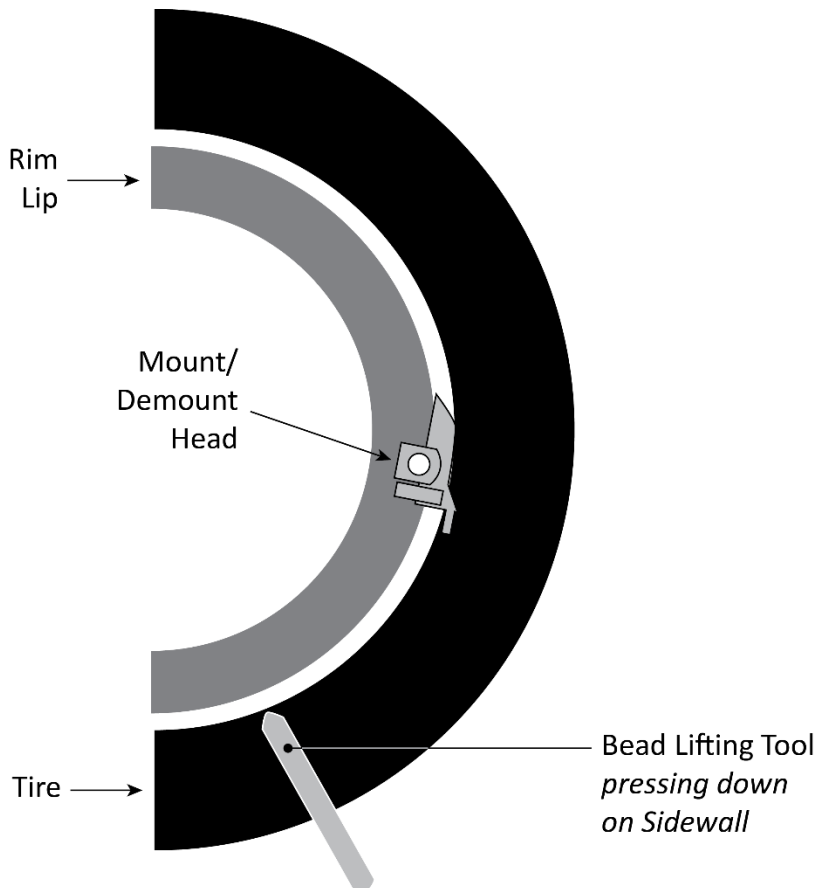

Top view. Not to scale.

11. When you start rotating the Tire, move the Bead Lifting Tool around as the Tire moves around, keeping the Tool at the same spot on the Tire.

12. If using the R76LT, position the Assist Tool, if desired, to the left of the Mount/Demount Head (about 20% of the total distance around the Tire), with it pushing down on the Sidewall of the Tire. Then position the Bead Roller, if desired, to the left of the Mount/Demount Head, with it also pushing down on the Sidewall of the Tire.

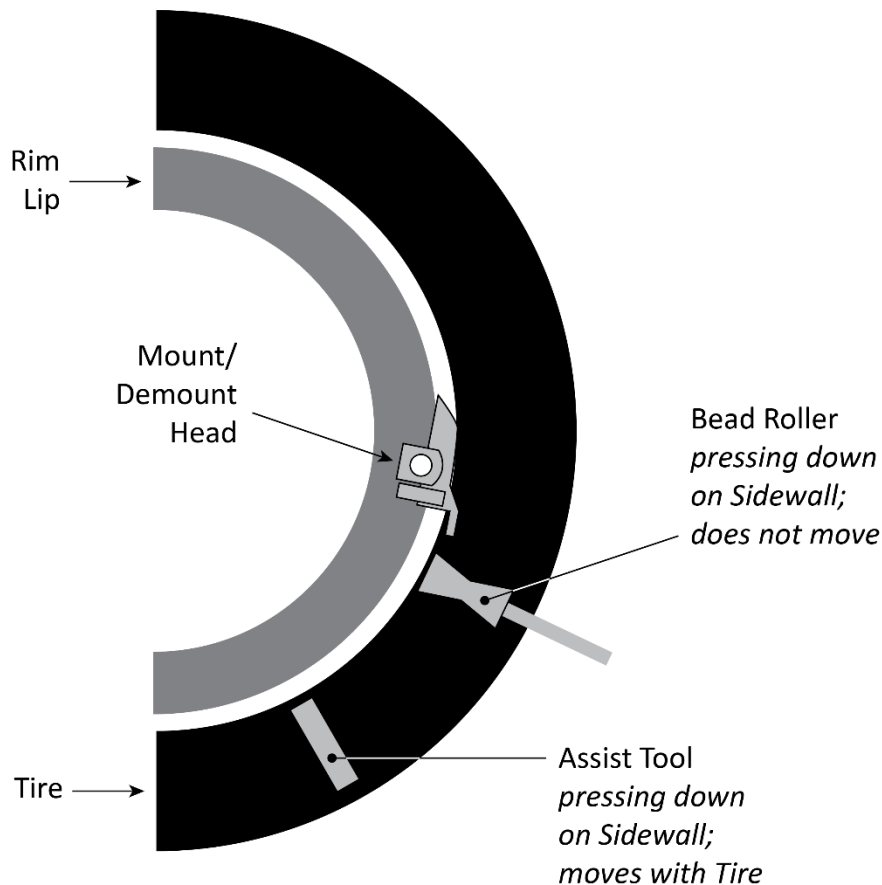

Top view. Not necessarily to scale.

When you start rotating the Tire, the Assist Tool, if used, moves with the Tire. The Bead Roller, if used, stays in the same spot.

13. Press down and hold down the Turntable Foot Pedal to move the Turntable clockwise.

If using the Bead Lifting Tool or Assist Tool to hold down the Sidewall, move them around with the Tire as it rotates.

14. If you run into any difficulty as the Tire rotates, take your foot off the Turntable Foot Pedal to stop the Turntable, then press up on the Turntable Foot Pedal to move the Turntable counterclockwise. Make any necessary adjustments and then proceed.

Eventually the top Bead slips under the Rim. How long this takes can vary, based on the Tire you are mounting. Some Tires are more difficult than others.

⚠ CAUTION **Do not use excessive force.** If the Turntable slows and then stops while you are holding down the Turntable Foot Pedal, do not try to force it to continue. Using excessive force can damage the Tire, Wheel, or the Tire Changer and voids the Warranty.

Inflate the Tire

Tire inflation has three stages:

- **Bead sealing** is putting in a small amount of air pressure to push the Tire up against the Rim so the rest of the air you put in does not leak out. *Remove the Valve Core before beginning the Bead sealing*, as that allows more air to go in through the Valve Stem. Remember to put the Valve Core back in once both Beads are seated (before inflation). If you have difficulty sealing the Beads (you hear air escaping from between the Tire and the Rim), you can use the Turbo-Blast™ nozzle.
- **Bead seating** is putting more air pressure into the Tire until you hear a “pop”, which indicates the Beads (on both sides of the Tire) have slipped over the Bead Retainer into their Bead Seats. *Put the Valve Core back in once the Beads are seated.*
- **Inflation** is adding more air pressure to the Tire to get the pressure up to the manufacturer’s recommended pressure for the Tire. **Do not stand over the Tire when inflating.**

Each of these stages is covered separately below.

CAUTION The inflation process can produce noise. Wear ear protection when inflating a Tire.

WARNING Do not exceed the maximum air pressure specified by the Tire manufacturer. This increases the chances that the Tire could explode, causing injury or even death to the Operator and bystanders.

Use the Pressure Gauge on the Tire Changer to monitor the air pressure in the Tire you are inflating.

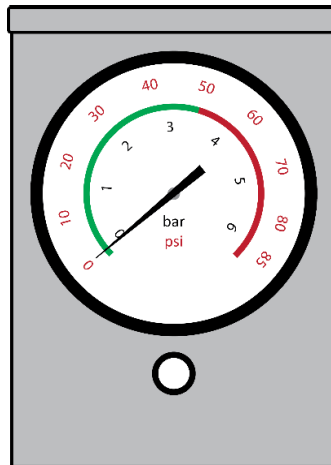

DANGER If you are inflating a Tire that requires more than 60 psi, you **must** use a **Tire Inflation Cage such as the RIC-4716** for safety purposes. If a Tire fails at high pressure, it can explode and cause serious injury or death to anyone near it. Using a Tire Inflation Cage helps reduce the danger.

Important inflation notes:

- Identify the **recommended** inflation pressure of the Tire (usually located on a sticker on the driver-side doorjamb) and the **maximum** inflation pressure of the Tire (usually located on the sidewall). When inflating, your goal is the recommended inflation pressure; do not exceed the maximum inflation pressure when inflating the Tire.
- Make sure the Tire is restrained for inflation: either *internally* clamped, held down by a Restraint Cone (R76ATR only), or in a Tire Inflation Cage. Do not inflate a Tire if it is **externally** clamped; external clamping interferes with inflation.

Bead Sealing

To seal a Tire's Beads, you put a small amount of air pressure into the Tire, which pushes the Tire up against the Rim so that additional air you put in does not leak out.

To Seal the Beads:

1. Make sure you are wearing OSHA-approved (publication 3151) personal protective equipment: leather gloves, steel-toed work boots, back belts, hearing protection, and ANSI-approved eye protection (safety glasses, face shield, or goggles).
2. Make sure the Valve Core has been removed.
3. Clip the Air Chuck to the Valve Stem.

The Air Chuck includes a self-gripping clip, so you do **not** have to hold it in place during inflation.

⚠ WARNING ***Do not hold the Air Chuck while you are inflating a Tire.*** This leaves you close to the Tire, which could result in injury if there is a problem during inflation.

4. Press and hold down the Inflation Foot Pedal for a second or two, then release.

Air goes into the Tire and seals the Bead.

Bead Seating usually requires 7 psi or above.

Some Beads are hard to seat, but never exceed 40 psi to seat the Bead.

The Bead is sealed when you no longer hear the sound of air coming out from between the Wheel Rim and the Tire Beads.

5. Check to make sure the upper and lower Beads are sealed against the Rim.

If the Beads are **not** sealed, try again, this time putting in slightly more air.

6. If the Bead is still not sealed, position the Turbo-Blast™ nozzle about an inch from where the Wheel meets the Rim Edge and press the Button. You want the air blast to go under the Rim and into the Tire, sealing the Bead.

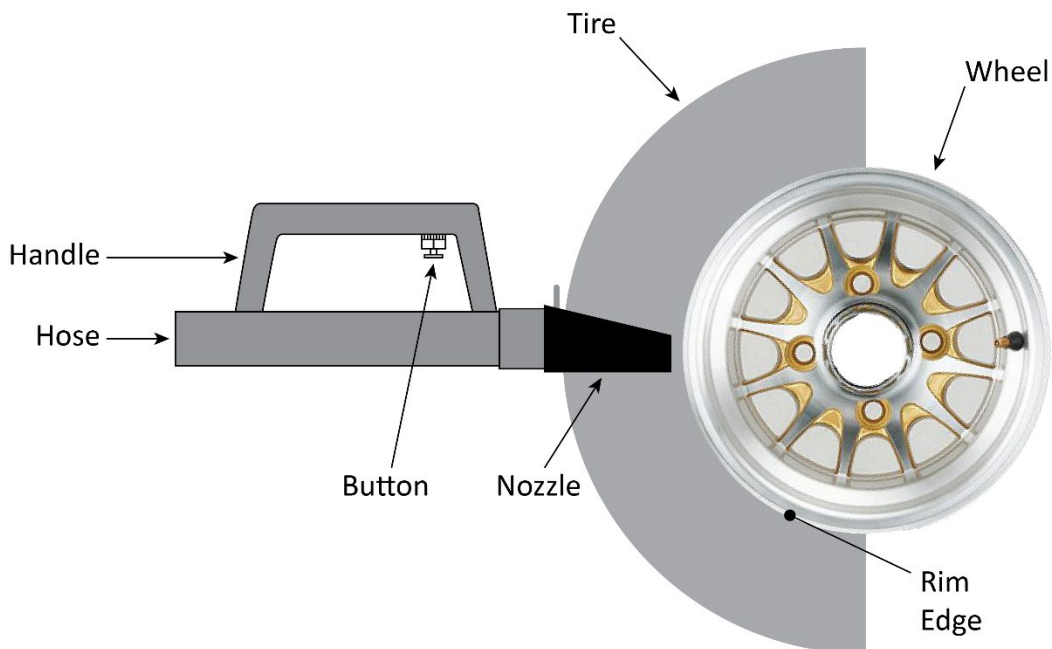

Side view shown; nozzle must be held flat to use. Not to scale. Not all components shown.

Bead Seating

To seat a Tire's Beads, you put in additional air pressure until you hear a "pop", which indicates the Tire Beads have slipped over the Bead Retainers into their Bead Seats.

Remember that a Tire has Beads on *both sides* of the Tire. The Beads have to be seated on both sides. Bead Seating is not complete until the Beads are seated on both sides of the Tire.

⚠ WARNING ***Do not exceed 40 psi to seat a Bead.***

The following procedure assumes the Tire's Beads have already been sealed. Do not try to seat the Beads until the Beads have been successfully sealed.

To Seat the Beads:

1. Make sure the Air Chuck is clipped to the Valve Stem of the Tire.
2. Step back from the Tire.
3. Press and hold down the Inflation Foot Pedal.

Air begins flowing into the Tire.

After a few seconds, you should hear a "pop" as the Beads are seated.

Bead Seating usually requires 7 psi or above.

Some Beads are hard to seat, but never exceed 40 psi to seat the Bead.

If air pressure in the Tire gets to 40 psi but the Beads are still ***not*** seated, use the Pressure Relief Button to remove air down to about 5 psi and then try again to seat the Beads. If you lower the psi too far, you may lose the Bead seal and have to do that again.

4. Release the Inflation Foot Pedal.
5. If the Beads do not seat on a second attempt, either:
 - Re-lube the tire beads
 - Re-position the tire on the rim
 - Verify that the valve core has been removed from the valve stem
6. If the amount of air pressure it takes to seat the Beads exceeds the manufacturer's recommended psi for the Tire, use the Pressure Relief Button to remove air pressure from the Tire, bringing it back down to the recommended psi for the Tire.
7. When the Beads are seated, remove the Air Chuck from the Valve Stem and **reinstall the Valve Core**.

Inflating the Tire

To inflate a Tire after sealing and then seating the Beads, add air pressure to the Tire to get the pressure to the manufacturer's recommended pressure.

Use the Pressure Gauge to monitor air pressure.

⚠ DANGER If you are inflating a Tire that requires more than 60 psi, you **must** use a **Tire Inflation Cage such as the RIC-4716** for safety purposes. If a Tire fails at high pressure, it can explode and cause serious injury or death to anyone near it. Using a Tire Inflation Cage helps reduce the danger.

The typical inflation pressure for automobile Tires is from approximately 25 to 45 psi. Light truck Tire inflation pressures typically cover a wider range.

Do not exceed the Tire manufacturer's **maximum** air pressure for a Tire. Your goal is to get to the Tire's **recommended** pressure.

The Tire Changer has an air pressure limiter that is set at the factory so that it does **not** exceed 60 psi. **Do not override the pressure limiter.**

⚠ DANGER Inflating a Tire with a bypassed pressure limiter could result in the Tire exploding, which could injure or kill bystanders or the Tire Changer Operator.

To inflate a Tire:

1. Verify that both the upper and lower Beads are sealed and seated.
2. Verify that the Valve Core has been reinstalled.
3. Make sure the Air Chuck is clipped to the Valve Stem of the Tire using the self-gripping clip.
4. Step back from the Tire.

⚠ DANGER Do **not** stand over the Tire when inflating it. If the Tire explodes during inflation (which does not happen often, but does happen), you could be injured or killed if you are standing over the Tire when it explodes.

5. Press and hold down the Inflation Foot Pedal.
Air begins flowing into the Tire.
6. Inflate the Tire to the manufacturer's **recommended** pressure by monitoring the Pressure Gauge.
7. Release the Inflation Foot Pedal.
8. Remove the Air Chuck from the Valve Stem.
9. Take the Wheel off the Tire Changer.

Maintenance

Make sure your Tire Changer is maintained on a regular basis.

 **WARNING** Disconnect the Tire Changer from power and incoming air **before performing any Maintenance**. Take whatever steps are necessary to make sure the unit cannot be re-energized until Maintenance is over (such as Lockout/Tagout). Because the unit uses electrical and pneumatic energy, you could be electrocuted or even killed if the unit is powered back on during Maintenance.

The Tire Changer uses pneumatic and electrical energy; if your organization has **Lockout/Tagout policies**, make sure to implement them before performing maintenance on the Tire Changer.

Regular Maintenance

- **Daily:** Make sure the unit is clean and dry.
- **Weekly:** Check all labels to make sure they are in place and legible. Contact BendPak Ranger if replacement labels are needed.
- **Weekly:** Check the water level of the Regulator/Filter. If the reservoir is one quarter (25%) or more filled with water, drain it. Refer to **Check the Water Level** for instructions.
- **Weekly:** Check the oil feed rate of the Oiler/Lubricator. It should be 1 to 2 drops per use of a pneumatic component. If it is above or below this level, you need to adjust it. Refer to **Check the Oil Feed Rate and Adding Oil** for instructions.
- **Weekly:** Check the amount of pneumatic oil in the Oiler/Lubricator reservoir. If it is under one half (50%) full, add oil. Refer to **Check the Oil Feed Rate and Adding Oil** for instructions.
- **Monthly:** Check the accuracy of the Inflation Gauge using a pressurized tire and a high-quality pressure gauge. Fix immediately if not working correctly.
- **Monthly:** Make sure all Anchor Bolts are tightened and secure, if used.
- **Monthly:** Make sure all components are in good operating condition. If you find a component that is **not** working correctly, take the Tire Changer out of service and refer to **Troubleshooting** for more information.
- **Twice a Year:** Have a licensed Electrician check the electronic components.
- **Yearly:** Take the Tire Changer out of service, disconnect it from power, and then thoroughly check and clean all components.

 **WARNING:** Do not operate your Tire Changer if you find issues; instead, take the unit out of service, then contact your dealer, visit rangerproducts.com/support/, or call **(805) 933-9970**.

Check the Water Level

Water coming in via the incoming air is removed by the Regulator/Filter and dropped into the reservoir at the bottom.

This water needs to be drained periodically.

To drain water from the Regulator/Filter reservoir:

1. Check the Water Sight Gauge to see how much water is currently in the reservoir.
If the reservoir is a quarter (25%) or more filled with water, you need to drain it.
2. Disconnect the incoming air at the Air In connector.

⚠ WARNING Make sure to disconnect the incoming air and make sure it cannot be reconnected until you are done draining the water from the Regulator/Filter. If the incoming air is reconnected during the procedure, it could damage the Regulator/Filter, the Tire Changer, and possibly injure bystanders.

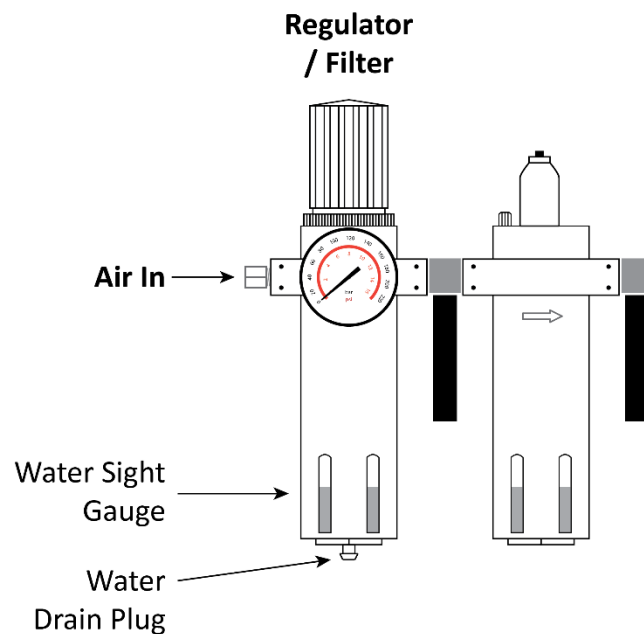

3. Press upwards on the Water Drain Plug at the bottom of the reservoir.
The water drains out.
4. Release the Water Drain Plug.
5. Re-connect the incoming air.

Check the Oil Feed Rate and Adding Oil

The built-in lubricator adds pneumatic oil to the incoming air. This ensures that all pneumatic components of the Tire Changer receive the necessary lubrication, which maintains operating performance, reduces wear, and extends service life.

It is very important to make sure the oil feed rate is correct, 1 or 2 drops of oil per use of pneumatic component (such as the Clamps Foot Pedal), and that there is enough pneumatic oil in the Oil Reservoir of the Oiler/Lubricator.

To check the oil feed rate on the Oiler/Lubricator:

1. With the Air Source connected, press down and then release the Clamps Foot Pedal.
You do not need a Tire, you just need to use a pneumatic tool.
2. Watch the Sight Glass to see how much pneumatic oil comes out each time you use the Clamps Foot Pedal.
Your goal is for 1 or 2 drops to come out for each use.
3. If you are getting **fewer** than 1 or 2 drops, turn the Adjustment Screw counter-clockwise (using a small flat-head screwdriver), then use the Clamps Foot Pedal again to check the output.
4. If you are getting **more** than 1 or 2 drops, turn the Adjustment Screw clockwise, then use the Clamps Foot Pedal again to check the output.
5. When you are getting 1 or 2 drops, stop turning the Adjustment Screw.

To add pneumatic oil to the Oiler/Lubricator:

1. Check the Oil Sight Gauge to see how much pneumatic oil is currently in the reservoir.
If the reservoir is less than half (50%) filled with pneumatic oil, add oil.
2. Disconnect the incoming air at the Air In connector.
3. Turn the Oil Fill Cap on the top of the Oil Reservoir counter-clockwise and pull it off.
4. Add SAE 10W Air Tool Oil or generic pneumatic oil to the reservoir.
5. Put the Oil Fill Cap back in place, turning it clockwise until tight.
6. Re-connect the incoming air.

Troubleshooting

⚠ WARNING: Disconnect the Tire Changer from power and incoming **before performing any maintenance**. Take whatever steps are necessary to make sure the unit cannot be re-energized while maintenance is being performed on it (such as Lockout/Tagout). The unit uses pneumatic and electrical energy; if your organization has Lockout/Tagout policies, make sure to implement them before troubleshooting the Tire Changer.

| Issue | Action to Take |
|---------------------------------------------------------------------------------------|-----------------------------------------------------------------------------------------------------------------------------------------------------------------------------------------------------------------------|
| The Turntable does not move when you step on the Turntable Foot Pedal. | Make sure the unit is getting power. |
| The unit is not getting power. | Have a licensed, certified Electrician check the electrical path from the supplied cord to the power source. If any issues are found, have them fixed. Refer to Wiring Information for additional information. |
| No air comes out when you step on the Inflate Foot Pedal. | Make sure the unit is correctly connected to a working incoming air source. |
| It is difficult to secure Tires when clamping externally. | Use the Restraint Cone to press the Tire down so the Clamps correctly grab the Rim of the Wheel. R76ATR only. |
| The Inflation Gauge is not working correctly. | Check the accuracy of the Inflation Gauge with a professional gauge. Fix immediately if the Inflation Gauge is not working correctly. |
| The Assist Arms (R76ATR only) move up and down slowly or make odd noises when moving. | Grease the Assist Tower Post, it has run out. Refer to Grease the Assist Tower Post for additional information. |

If you continue to have problems with your Tire Changer, visit www.bendpak.com/support/ or call **BendPak Ranger at (805) 933-9970**.

Wiring Information

The Tire Changer comes with a Power Cord that is connected inside the unit and with three exposed wires on the other end. The three exposed wires need to be hard-wired to the facility's power system or connected to a 208-240 VAC, 30 amp Plug (which is then connected to a power outlet).

⚠ WARNING: All electrical work, such as hard-wiring the unit to the facility's power system or attaching a Plug to a Power Cord, **must be done by a licensed, certified Electrician** in accordance with all applicable local electrical codes. Damage to the unit caused by improper electrical installation voids your warranty.

The Tire Changer does **not** come with a 208-240 VAC **Plug**; you must supply one.

The colors of the three exposed wires are Brown, Blue, and Green/Yellow, the European color code.

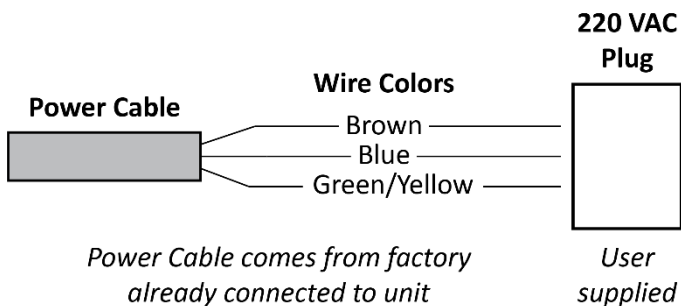

Important: To connect the three exposed wires to an appropriate Plug or to hard wire them, have your Electrician follow the electrical codes for the country in which you are using the unit and any local electrical codes.

For example, if you are using the unit in the United States, the color codes on the wiring that comes with the Tire Changer correspond to:

- **Brown:** Live
- **Blue:** Live
- **Green/Yellow:** Ground

If you were using the unit in a European country, the color codes on the wiring that comes with the Tire Changer correspond to:

- **Brown:** Live
- **Blue:** Neutral
- **Green/Yellow:** Ground

Information about color code conventions in other regions and countries is available online. Make sure your Electrician installs the Plug or hard wires the Tire Changer in accordance with all applicable local electrical codes.

Labels

A



R76ATR version. R76LT says "R76LT".

B

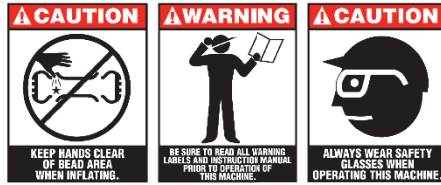

C

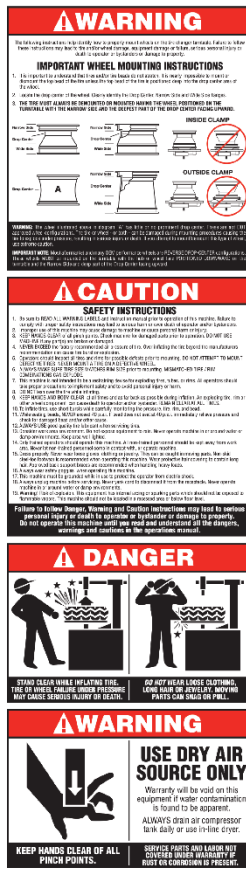

D

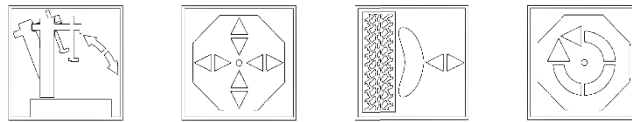

E



F



G



H



I



J



K



L

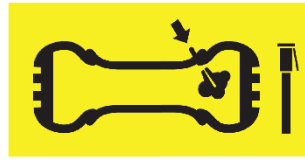

M**N****O****Q**

▲ IMPORTANT

FILTER / REGULATOR LUBRICATOR INSTRUCTIONS

WARNING!

Failure to regularly drain water and maintain proper oil level and oil feed rate will damage internal pneumatic components and void product warranty.

The inline lubricator helps ensure that all pneumatic components inside this machine receive the required lubrication to maintain operating performance, reduce wear and prolong service life. It is designed to automatically provide the correct amount of oil feed rate required within the pneumatic system delivering a constant ratio of oil to CFM.

The filter/regulator is designed to remove airborne solid and liquid contaminants which may plug small orifices and hinder performance or cause excessive wear and premature equipment failure. The regulator provides controlled and consistent air pressure as required. NOTE: This model requires 15-25 CFM air source with a safe operating air pressure of 140-165 PSI for optimum machine performance.

Water Separator / Lubricator Maintenance

- Check oil and water levels regularly and perform these maintenance items weekly.
- Observe the water sight gauge on the water separator/filter unit. If water is observed, drain by pressing upwards on the drain plug at the bottom of the reservoir.
- Observe the sight glass and adjust the oil feed rate by turning the small adjustment screw on the top of the glass bowl so that 2-3 drops of oil drip through the site glass for each operation of the bead loosener pedal.

Adding Oil to Oiler / Lubricator

If oil level is low, add oil as follows:

1. IMPORTANT - First disconnect air source from machine.
2. Remove oil reservoir by unthreading reservoir from head of oiler/lubricator.
3. Add oil as necessary.
4. Replace reservoir making sure rubber O-ring is seated properly and reservoir is firmly tightened hand-tight.

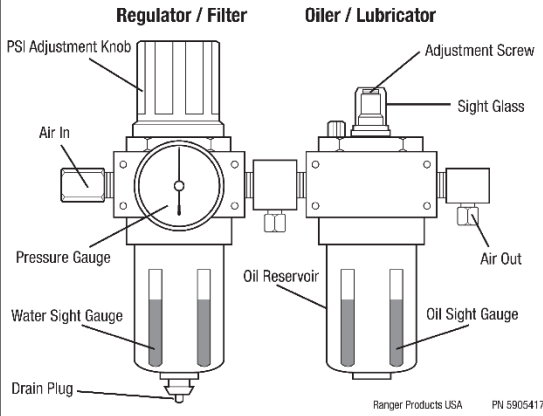
**P**

POWER ASSIST

S

CALIFORNIA PROPOSITION 65

▲ WARNING ▲

WARNING: This product contains chemicals known to the State of California to cause cancer and birth defects or other reproductive harm.
ADVERTENCIA: Este producto contiene sustancias químicas reconocidas por el estado de California como causantes de cáncer y defectos de nacimiento u otros daños reproductivos.

For more information visit:
www.P65Warnings.ca.gov

Proposition 65 Label on packaging only.

T

BendPak 50 Year Label on Packaging only.

R

Use Moly-Graphite Grease to ensure proper lubrication of slide plates.

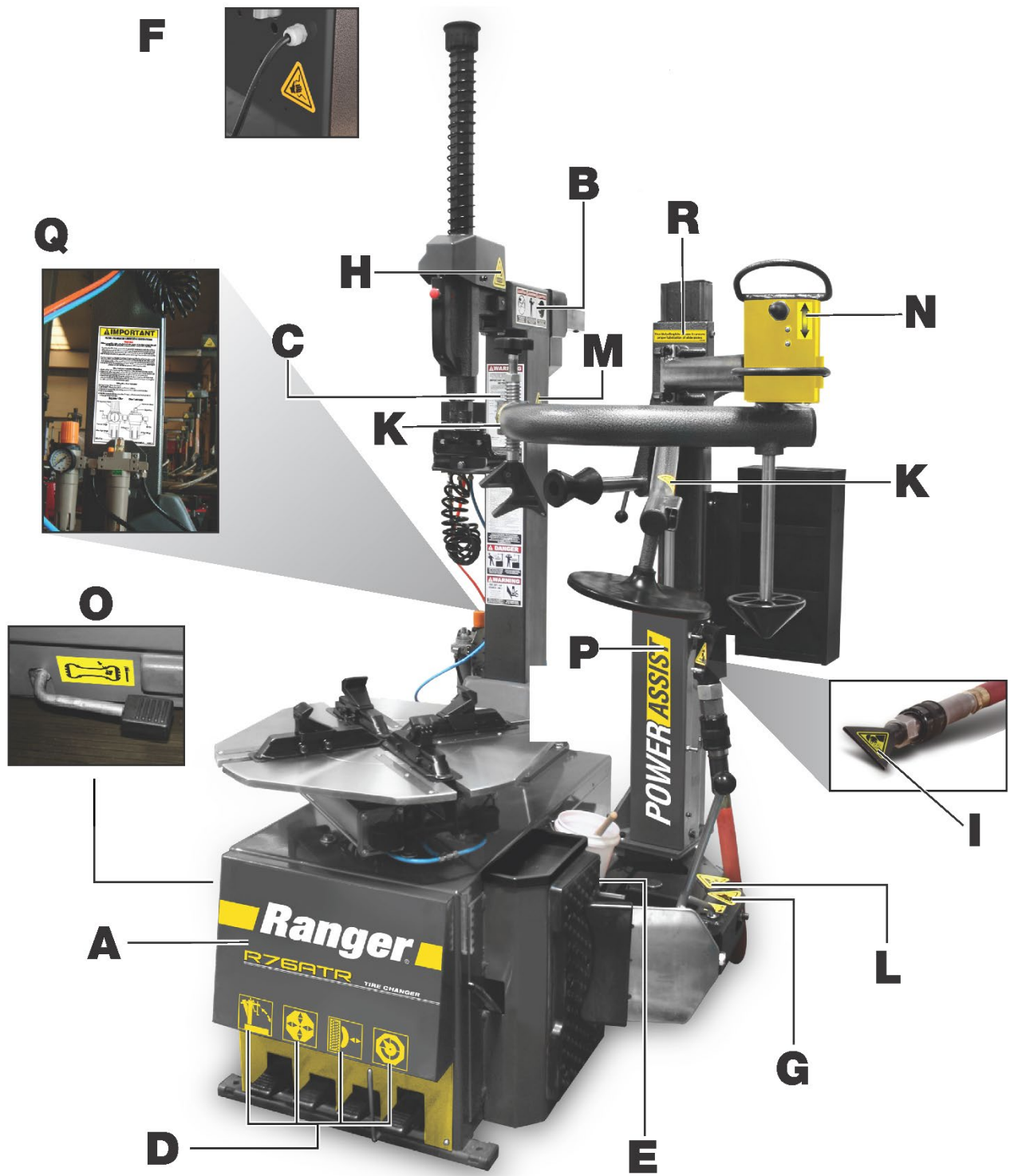

The R76LT does not have an Assist Tower, so it also does not have the labels shown on the Assist Tower in the graphic above.

Parts

Cabinet

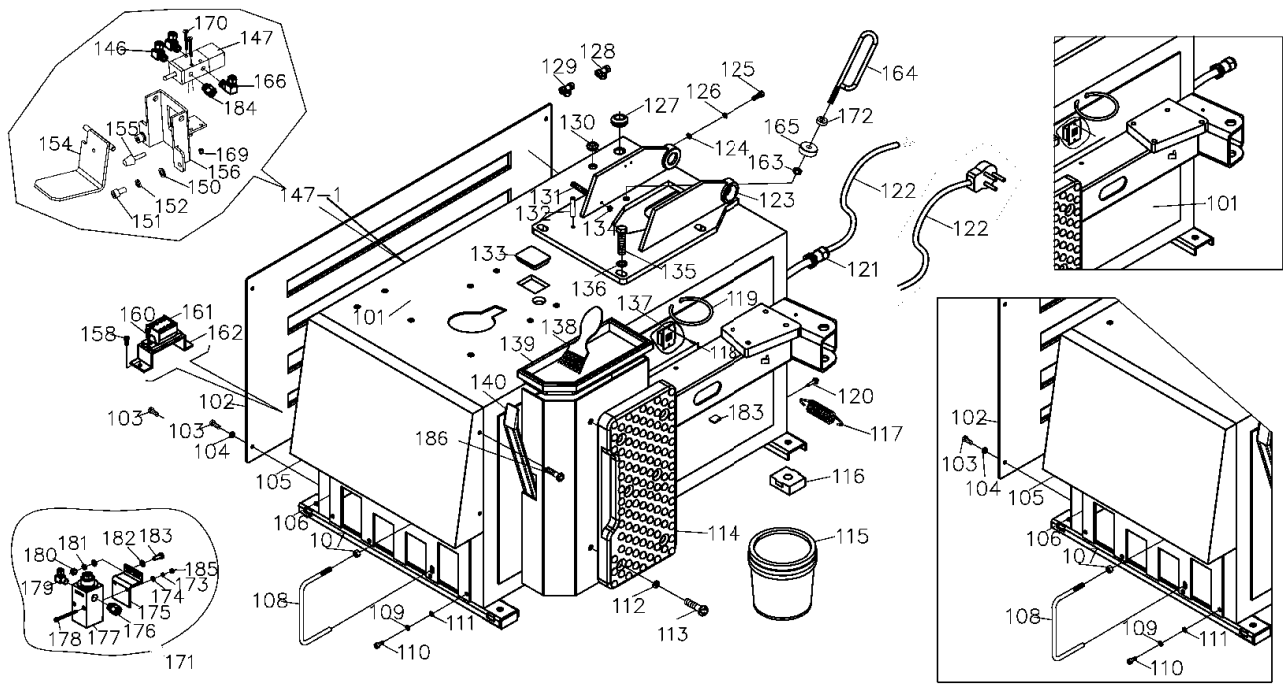

| BendPak Part # | Drawing # | Description |
|----------------|-----------|---------------------------------------------|
| | 101 | Chassis body |
| | 101 | Chassis body |
| | 101 | Chassis body |
| | 101 | Chassis body |
| 5327131 | 102 | Side cover |
| | 103 | SHCS, M6 x 16 |
| | 103 | Cross groove large Flat Head Screw, M6 x 12 |
| 5400913 | 104 | Washer, $\varnothing 6$ Flat |
| | 105 | Pedal cover |
| | 105 | Pedal cover |
| | 106 | Chassis front board |
| | 107 | Nut, M8 |
| 5327721 | 108 | Foot pedal divider |
| | 109 | Washer, M6 flat |
| 5327730 | 110 | SHCS, M6 x 16 |
| 5400913 | 111 | Washer, M6 flat |
| | 112 | Washer, M6 flat |
| | 113 | Cross recessed pan head screw, M6 x 25 |
| 5327101 | 114 | Wheel support pad |
| 5400120 | 115 | Soap bucket |

| | | |
|---------|-------|------------------------------------------------------------------------------|
| 5327307 | 116 | Plastic foot pad |
| 5327349 | 117 | BB return spring, $\varnothing 3 \times \varnothing 25 \times 23 \times 140$ |
| | 118 | Cross recessed pan head screw, M3 x 10 |
| 5400119 | 119 | Soap bucket retaining ring |
| | 120 | STS, M5.5 x 25 |
| | 121 | Power cord grip |
| 5401121 | 122 | Power cord |
| | 122 | Power cord |
| | 123 | Vertical arm base |
| | 124 | Washer, $\varnothing 5$ flat |
| | 125 | SHCS, M5 x 20 |
| | 126 | Washer, $\varnothing 5$ split lock |
| | 127 | Cable holder, $\varnothing 16$ |
| | 128 | Fitting, tee $\varnothing 8\text{-}\varnothing 8\text{-}\varnothing 8$ |
| | 129 | Fitting, G 1/8" $\varnothing 6$ |
| | 130 | Cable holder, $\varnothing 12$ |
| | 131 | Slotted flat head screw, M10 x 40 |
| | 132 | Pin, $\varnothing 6 \times 40$ |
| 5327308 | 133 | Tire changer body plug |
| | 134 | Nut, M10 |
| | 135 | HHB, M12 x 70 |
| | 136 | Washer, flat |
| 5327444 | 137 | Voltage switch, 110V/220V |
| 5400121 | 138 | Soap brush |
| 5327348 | 139 | Tool tray |
| 5400110 | 140 | Pry bar |
| 5400933 | 146 | Fitting, 8 mm x 1/8" 90° |
| | 147 | Inflation foot pedal Valve B |
| 5327462 | 147-1 | Tire inflator Valve assembly |
| | 150 | Washer, $\varnothing 8$ flat |
| | 151 | SHCS, M8 x 16 |
| | 152 | Washer, $\varnothing 8$ split lock |
| 5327421 | 154 | Inflation foot pedal weldment |
| | 155 | Inflation foot pedal limit block |
| 5327420 | 156 | Inflation pedal bracket |
| | 163 | Nut, M8 |
| | 164 | Column limit rod |
| | 165 | Tilt tower bushing |
| 5400007 | 166 | Fitting, G1/4" $\varnothing 8$ 90° |
| | 169 | Lock nut, M4 |
| | 170 | Cross recessed pan head screw, M4 x 35 |
| | 171 | Inflation regulator assembly |
| | 172 | Washer, $\varnothing 8$ |

| | | |
|---------|-----|--------------------------------------|
| | 173 | Washer, \varnothing 4 split lock |
| | 174 | Washer, \varnothing 4 flat |
| | 175 | Full flow inflation kit bracket |
| | 176 | Fitting, G1/4" \varnothing 8 |
| | 177 | Full flow inflation regulator |
| | 178 | SHCS, M4 x 50 |
| 5400007 | 179 | Fitting, G1/4" \varnothing 8 90° |
| | 180 | Nut, M6 |
| | 181 | Washer, \varnothing 6 split lock |
| | 182 | Washer. \varnothing 6 flat |
| | 183 | HHB, M6 x 20 |
| | 184 | Fitting, G1/4" \varnothing 8 |
| | 185 | Nut, M4 |
| | 186 | Cross recess pan head screw, M6 x 10 |
| | 187 | Side wall |

Main Tower

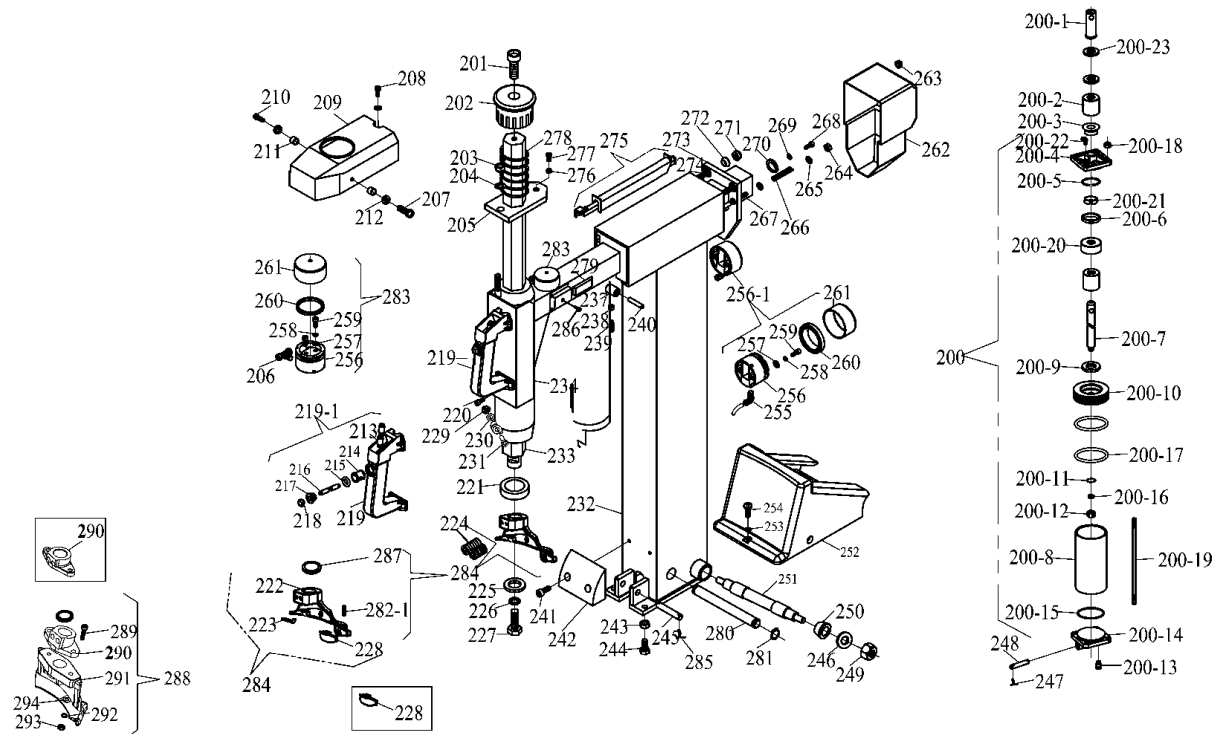

| BendPak Part # | Drawing # | Description |
|----------------|-----------|---------------------------------|
| 5327390 | 200 | Tilt back cylinder |
| | 200-1 | Tilt cylinder connector |
| | 200-2 | Tilt tower rubber spacer |
| | 200-3 | Rubber shock bushing |
| | 200-4 | Tilt tower cylinder front plate |
| | 200-5 | O-Ring, Ø25 x 3.1 |
| | 200-6 | Y-Ring, Ø32 x 20 x 6 |
| | 200-7 | Tilt tower cylinder rod |
| | 200-08 | Tilt tower cylinder |
| 5327501 | 200-9 | Washer |
| | 200-10 | Small cylinder piston |
| | 200-11 | O-ring, Ø16 x 2.4 |
| | 200-12 | Nut, M12 |
| | 200-13 | Fitting, G1/8" Ø8, straight |
| | 200-14 | Tilt tower cylinder rear plate |
| | 200-15 | O-ring, Ø75 x 2.65 |
| | 200-16 | Washer, Ø12 split lock |
| 5327645 | 200-17 | O-ring, Ø75 x 5.7 |
| | 200-18 | Nut, M8 x 1 |
| 5327502 | 200-19 | Tilt back cylinder bolt |
| | 200-20 | Tilt cylinder front flange |
| | 200-21 | Tilt tower cylinder wear strip |
| | 200-22 | Fitting, G1/8" Ø8, 90° |
| | 200-23 | Washer |

| | | |
|---------|-------|-------------------------------------|
| | 201 | SHCS, M10 x 25 |
| 5400240 | 202 | Hex shaft cap |
| 5400457 | 203 | Nut, M10 NL |
| | 204 | Washer, Ø10 flat |
| 5327416 | 205 | Vertical shaft locking plate |
| 5327549 | 206 | Fitting, G1/8" Ø6, tee |
| 5400957 | 207 | SHCS, M6 x 20 |
| 5400957 | 208 | SHCS, M6 x 20 |
| 5327340 | 209 | Hex shaft lock cover |
| | 209 | Hex shaft lock cover |
| 5327340 | 209 | Hex shaft lock cover |
| 5400959 | 210 | SHCS, M6 x 30 |
| 5327329 | 211 | Hex shaft lock cover bushing |
| | 212 | Washer, M6 flat |
| 5400929 | 213 | Fitting, Ø6, 1/8 straight |
| 5327485 | 214 | Locking Valve O-ring spacer |
| 5327491 | 215 | O-ring, Ø8 x 2.65 |
| | 216 | Locking Valve shaft |
| 5327563 | 217 | Locking Valve metal spacer |
| 5327516 | 218 | Locking Valve button |
| 5327350 | 219 | Locking Valve handle |
| 5327077 | 219-1 | Locking Valve handle assembly |
| | 220 | SHCS, M5 x 12 |
| 5327310 | 221 | Mount/Demount Head bushing |
| 5327356 | 222 | Metal duckhead |
| 5328119 | 223 | Duckhead insert, new |
| 5327468 | 224 | SSS, M12 x 16 |
| 5327436 | 225 | Duckhead retaining Washer |
| | 226 | Washer, M10 SL |
| | 227 | HHB, M10 x 20 |
| 5327636 | 228 | Roller Insert |
| 5327636 | 228 | Roller Insert (A) |
| | 229 | Nut, M8 |
| | 230 | Washer, Ø8 |
| | 231 | SHCS, M8 x 35 |
| | 232 | Tilt back tower |
| | 232 | Tilt back tower |
| | 232 | Tilt back tower |
| 5327418 | 233 | Hex shaft |
| | 234 | Horizontal arm unit |
| | 234 | Horizontal arm unit |
| | 234 | Horizontal arm unit |
| | 234 | Horizontal arm unit |
| 5327496 | 237 | Horizontal arm roller |
| | 238 | Nut, M8 |
| | 239 | Inner Hexangular Set Screw, M8 x 40 |

| | | |
|---------|-------|----------------------------------------|
| 5327497 | 240 | Horizontal arm roller pin |
| | 241 | SHCS, M6 x 20 |
| | 242 | Inner tilt tower cover |
| | 243 | Nut, M10 |
| | 244 | HHB, M10 x 30 |
| | 245 | Tilt tower cylinder upper pin |
| | 246 | Washer, M12 |
| | 246 | Washer, M14 |
| | 247 | Pin, Ø3.2 x 25 |
| | 248 | Tilt tower cylinder lower pin |
| | 249 | Locknut, M12 |
| | 249 | Locknut, M14 |
| | 250 | Tapered metal bushing |
| | 251 | Tilt tower pivot pin |
| 5328267 | 251 | Tilt tower pivot pin |
| 5327351 | 252 | Outer tilt tower cover |
| | 253 | Washer, Ø6 flat |
| | 254 | Cross recessed pan head screw, M6 x 20 |
| 5327547 | 255 | Fitting, G1/8" Ø6 90° |
| 5327454 | 256 | Arm lock cylinder base |
| 5327392 | 256-1 | Horizontal arm lock cylinder assembly |
| | 257 | Washer, M6 flat |
| 5327490 | 258 | O-ring, 7 x 1.9 |
| | 259 | SHCS, M6 x 40 BOC |
| 5327453 | 260 | Arm lock cylinder seal |
| | 261 | Arm lock cylinder piston |
| 5327128 | 262 | Real lock cylinder cover |
| | 263 | Locknut, M8 |
| | 264 | Nut, M8 |
| | 265 | Washer, Ø8 flat |
| 5327343 | 266 | Rear lock plate spring |
| 5327515 | 267 | Threaded rod |
| | 268 | SHCS, M6 x 16 |
| | 269 | Washer, M6 flat |
| | 270 | Rear lock plate bushing |
| 5400457 | 271 | Nut, M10 |
| | 272 | Horizontal slide stop |
| 5327633 | 273 | Horizontal shaft locking plate |
| 5327524 | 274 | Threaded rod |
| 5327342 | 275 | Air line guard |
| | 276 | Nut, M12 |
| 5530061 | 277 | SHCS, M12 x 25 |

| | | |
|---------|-------|----------------------------------------------|
| 5400237 | 278 | Hex shaft spring |
| | 279 | Tilt tower rubber shock |
| | 280 | Tilt tower cylinder limit pin |
| 5327525 | 281 | Snap ring, Ø20 |
| 5327727 | 282-1 | Duckhead roller pin |
| 5327392 | 283 | Vertical shaft lock cylinder assembly |
| | 284 | Mounting/demounting duckhead assembly (D) |
| | 285 | Pin, Ø4 x 28 |
| | 286 | Cross recessed pan head screw, 4.2 x 13 |
| | 287 | Mounting/demounting duckhead, Washer |
| | 288 | Plastic bird head assembly |
| | 289 | SHCS, M8 x 40 |
| | 290 | Duckhead flange adapter kit |
| 5328289 | 290 | Demount head flange adapter, 15 degree angle |
| 5150523 | 291 | Plastic bird head |
| 5545202 | 292 | Washer, M8 |
| 5327884 | 293 | Nut, M8 |
| 5402104 | 294 | Washer, M8 |

Turntable

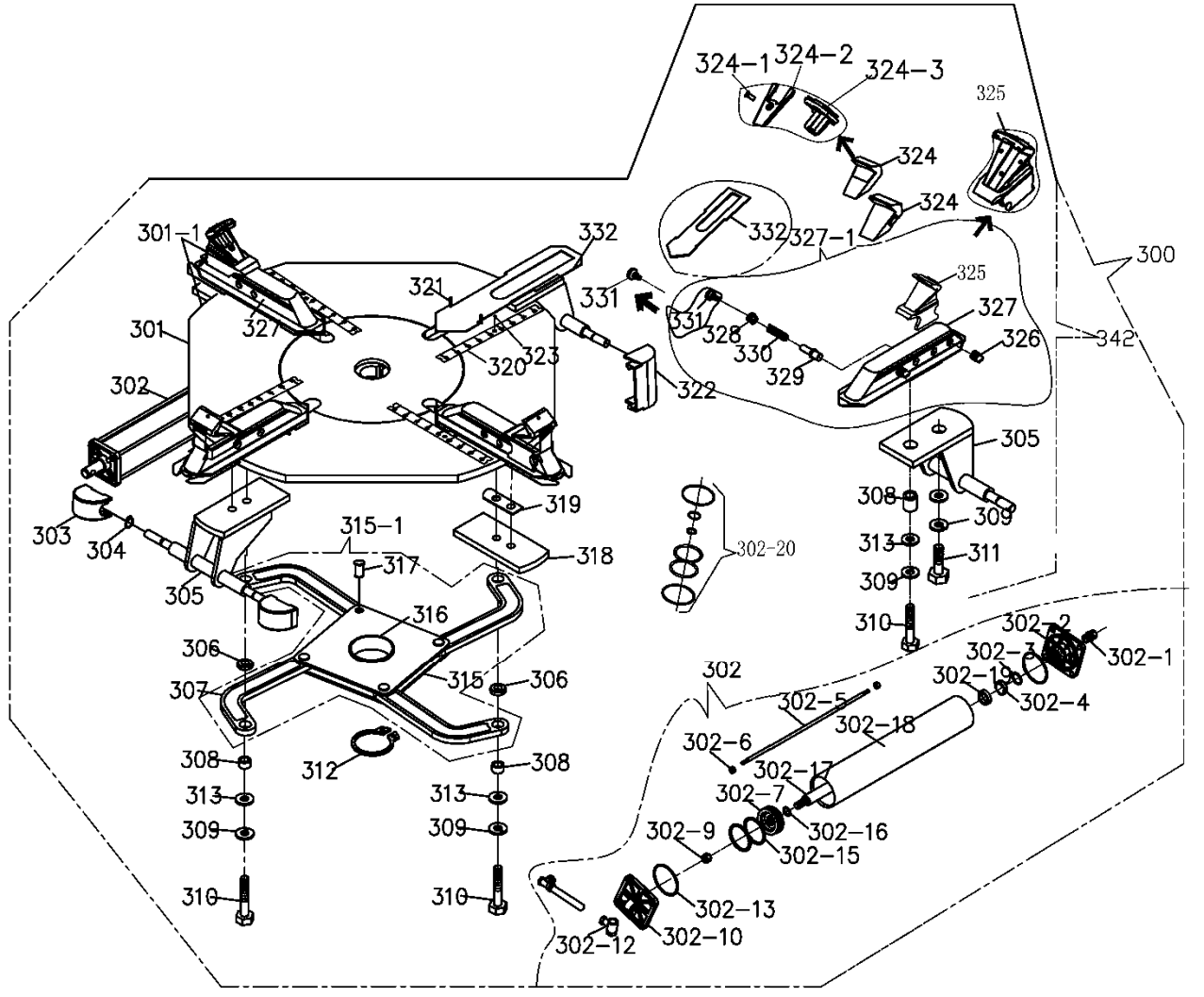

| BendPak Part # | Drawing # | Description |
|----------------|-----------|-------------------------------|
| 5327465 | 300 | Complete turntable assembly |
| | 300 | Complete turntable assembly |
| 5327713 | 301 | Turntable unit |
| | 301-1 | Plate assembly |
| 5327300 | 302 | Jaw clamp cylinder |
| 5327470 | 302-1 | Fitting, 1/8 8 mm, straight |
| 5327365 | 302-2 | Small front cylinder cover |
| 5327487 | 302-3 | O-ring, Ø25 x 3.1 |
| 5327540 | 302-4 | Jaw clamp cylinder wear strip |
| | 302-5 | Double-headed bolt |
| | 302-6 | Locknut, M8 |
| | 302-7 | Cylinder piston |
| | 302-9 | Locking nut, M12 |

| | | |
|---------|--------|--------------------------------------------------------------|
| 5327364 | 302-10 | Small rear cylinder cover |
| | 302-11 | Fitting Tee, $\varnothing 8 - \varnothing 8 - \varnothing 8$ |
| | 302-12 | Banjo bolt, G1/8" - single" |
| 5327488 | 302-13 | O-ring, 75 x 2.65 |
| 5327489 | 302-15 | O-ring, 75 x 5.7 |
| 5327486 | 302-16 | O-ring, $\varnothing 16$ x 2.4 |
| 5327407 | 302-17 | Jaw clamp cylinder rod |
| 5327406 | 302-18 | Jaw clamp cylinder body |
| 5327494 | 302-19 | Y-ring, $\varnothing 32$ x 20 x 6 |
| | 302-20 | Grommet assembly |
| 5327305 | 303 | Small cylinder cover |
| 5400905 | 304 | Snap ring, $\varnothing 12$ |
| 5327471 | 305 | Guard compound piece |
| | 306 | Spacer |
| | 307 | Square turntable link |
| 5327500 | 308 | Metal bushing |
| 5324269 | 309 | Washer, M12 SL |
| | 310 | HHB, M12 x 50 |
| | 311 | HHB, M12 x 25 |
| | 311 | HHB, M12 x 30 |
| | 312 | Snap Ring, $\varnothing 65$ |
| | 313 | Washer, $\varnothing 12$ |
| | 315 | Square turntable |
| 5327450 | 315-1 | Square turntable assembly |
| | 316 | Square turntable spacer |
| 5327521 | 317 | Square turntable press pin |
| | 318 | Slide guard board |
| 5327461 | 319 | Slide shim adjustment |
| | 320 | Turntable ruler |
| | 321 | Split pin, $\varnothing 4$ X 16 |
| | 321 | Pin, $\varnothing 4$ X 16 |
| 5327306 | 322 | Small cylinder cover |
| | 323 | Turntable ruler screw, M4 x 6 |
| 5327081 | 324 | Jaw clamp cover set |
| 5328234 | 324 | Jaw clamp cover set |
| 5328310 | 324-1 | SHCS, M4 x 10 |
| 5328312 | 324-2 | Plastic cover for jaw clamp |
| | 324-3 | Rubber cover for jaw clamp |
| 5327404 | 325 | Jaw clamp |
| 5328311 | 325 | Jaw clamp w/rubber insert |
| 5328400 | 326 | Special screw, M10 x 1 |
| 5327405 | 327 | Jaw clamp support |

| | | |
|---------|-------|---------------------------------|
| | 327-1 | Boat on the assembly |
| | 328 | Jaw clamp inner adjustment knob |
| 5327621 | 329 | Jaw clamp inner adjustment pin |
| | 330 | Jaw clamp pin spring |
| 5327623 | 331 | Jaw clamp locking pin |
| 5327623 | 331 | Jaw clamp locking pin |
| 5328328 | 332 | Boat gasket |
| | 342 | Complete turntable |

Bead Breaker

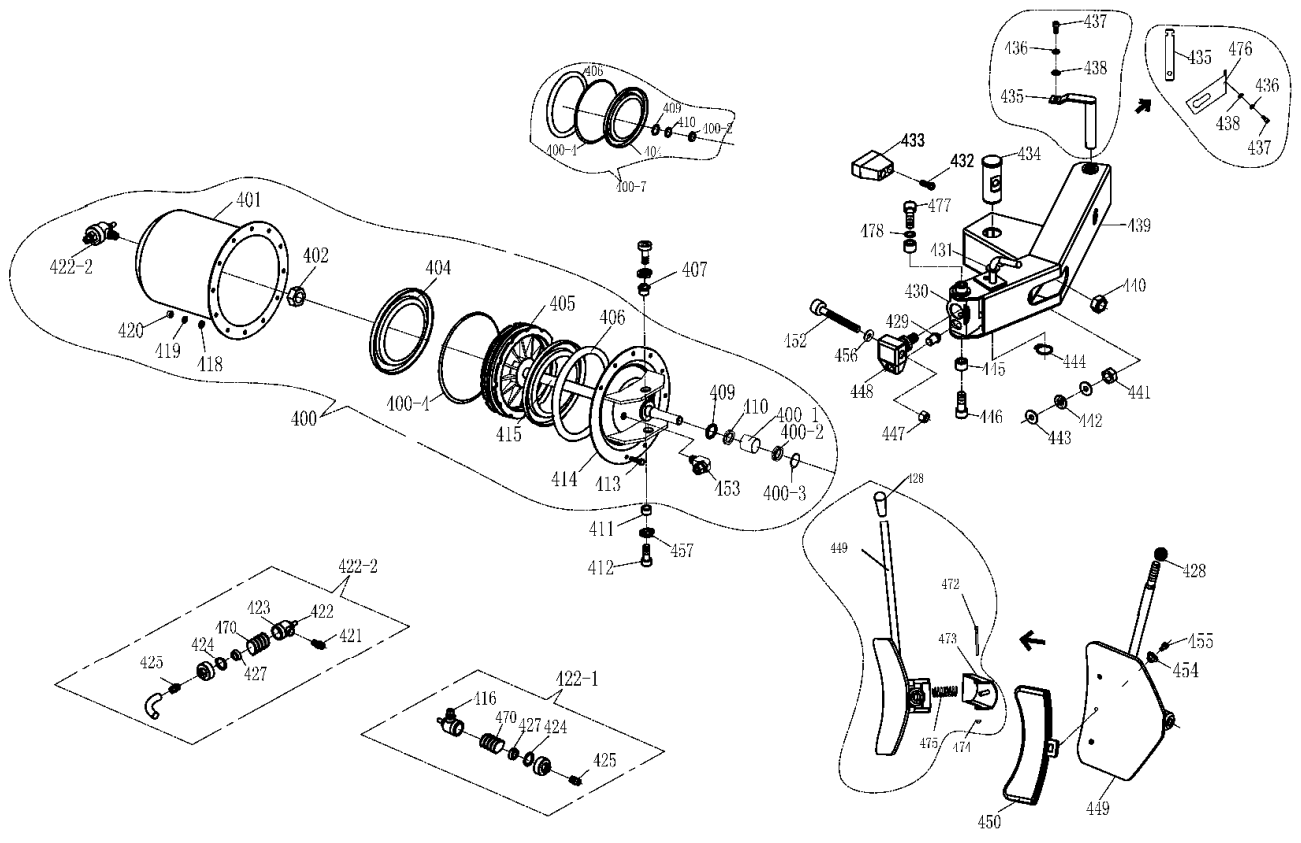

| BendPak Part # | Drawing # | Description |
|----------------|-----------|-----------------------------------------------|
| 5327271 | 400 | BB cylinder |
| | 400-1 | Bearing, Ø23 x Ø20 x 20 |
| | 400-2 | Seal ring, Ø30 x 20 x 7 |
| | 400-3 | Type I hole with elastic ring, Ø32 |
| | 400-4 | O-ring, Ø195 X 5.9 |
| 5327772 | 400-7 | Pairs of large cylinder seal hair accessories |
| | 401 | Cylinder liner |
| | 401 | Cylinder liner |
| | 402 | Nut, M18 - thin threaded |
| 5327682 | 404 | Y-ring, Ø200 x 12 x 6 |
| 5327413 | 405 | BB cylinder piston |
| 5327537 | 406 | O-ring, 193 x 5.7 |
| | 407 | Two plate of eccentric sleeve |
| 5327487 | 409 | O-ring, 25 x 3.1 |
| 5327493 | 410 | Y-ring, 25 |
| 5327500 | 411 | Metal bushing |
| | 412 | SHCS, M12 x 30 |
| | 413 | HHB, M6 x 16-8.8 |
| | 413 | SHCS, M8 x 16-8.8 |

| | | |
|---------|-------|-------------------------------------------|
| 5401520 | 414 | Bead breaker cylinder flange |
| 5401520 | 414 | Bead breaker cylinder flange |
| 5327437 | 415 | Bead breaker cylinder rod |
| | 416 | Fitting, G1/4" Ø10, straight |
| 5400913 | 418 | Washer, M6 flat |
| | 419 | Washer, M6 flat |
| | 419 | Washer |
| | 420 | Nut |
| | 420 | Nut |
| | 421 | Double nipple, G1/4'-G1/4" |
| 5327561 | 422 | Silencer, G1/4" |
| 5327815 | 422-1 | BB flow control Valve |
| 5327459 | 422-2 | BB flow control Valve |
| | 423 | Metal quick exhaust Valve |
| | 424 | Metal quick exhaust Valve leather cushion |
| | 425 | Fitting, G1/4" Ø10, straight |
| | 427 | Quick exhaust Valve metal cup |
| 5327608 | 428 | Bead breaker blade knob |
| | 428 | Bead breaker blade knob |
| 5327529 | 429 | BB blade stop pin |
| 5327570 | 430 | Bead breaker bracket |
| 5327757 | 431 | Bead breaker retaining pin |
| | 432 | SHCS, M6 x 25 |
| 5327183 | 433 | BB rubber bushing |
| 5327367 | 434 | Bead breaker arm pivot pin |
| 5328132 | 435 | Breaker arm pin |
| | 435 | Breaker arm pin shaft |
| | 436 | Washer, M6 flat |
| | 437 | SHCS, M6 x 16 |
| | 437 | SHCS, M6 x 12 |
| 5400913 | 438 | Washer, M6 flat |
| 5327722 | 439 | Bead breaker arm |
| | 440 | Locking nut, M16 |
| | 441 | Locking nut, M16 |
| | 442 | Curved spring Washers, Ø16 |
| | 443 | Washer, Ø16 |
| | 444 | Snap ring, Ø35 |
| 5327508 | 445 | Metal bushing |
| | 446 | SHCS, M12 x 25 |
| 5400947 | 447 | Locking nut, M14 |
| 5327738 | 448 | Bead breaker knuckle |
| 5327097 | 449 | Bead breaker blade |

| | | |
|---------|-----|--------------------------------------------------------------|
| | 449 | Bead breaker blade |
| | 449 | Bead breaker blade |
| 5327082 | 450 | Bead breaker blade cover |
| 5327609 | 452 | BB bolt, M14 x 95 |
| | 453 | Fitting, G1/4" Ø10, 90° |
| 5328083 | 454 | Bolted BB blade cover bushing assembly (includes 431-2 bolt) |
| | 455 | SHCS, M6 x 10 (included in assembly 5328083) |
| | 456 | Washer, Ø14 split lock |
| | 457 | Washer, Ø12 split lock |
| | 470 | Metal quick exhaust Valve spring |
| | 470 | Quick exhaust Valve pressure spring |
| 5328297 | 472 | SHCS, M8 x 85 |
| | 473 | Reset support, installed and welded |
| | 474 | Nut, M8 |
| | 475 | Press spring |
| | 476 | Shovel arm pin baffle |
| | 477 | SHCS, M12 x 30 |
| | 478 | Washer, Ø12 split lock |

Gearing

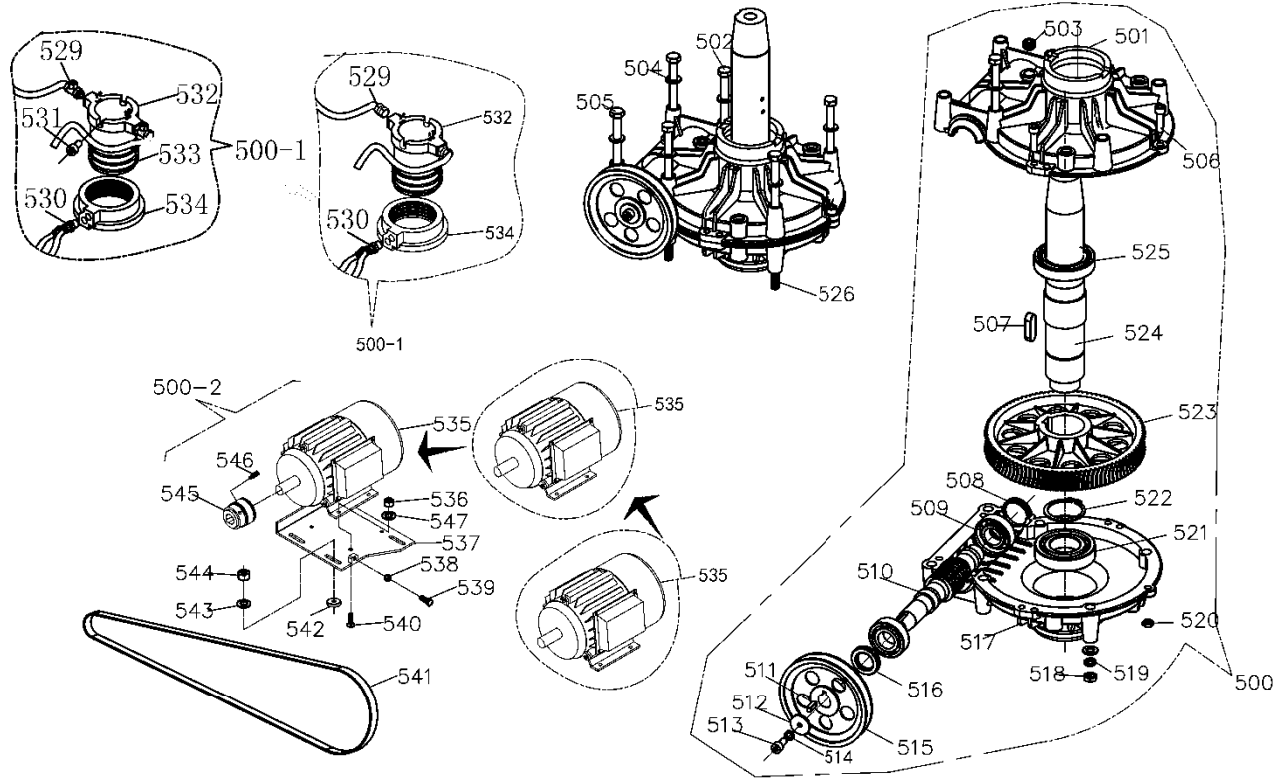

| BendPak Part # | Drawing # | Description |
|----------------|-----------|-------------------------------|
| 5327479 | 500 | Transmission assembly |
| 5327479 | 500 | Gearbox assembly |
| 5327175 | 500-1 | Rotary joint block (A) |
| 5327175 | 500-1 | Rotary joint block |
| | 500-2 | Motor assembly |
| | 500-2 | Motor assembly |
| | 501 | Transmission front flange |
| 5327520 | 502 | HHB, M10 x 200 |
| | 503 | Oil stud |
| | 504 | Washer, Ø10 |
| | 505 | HHB, M10 x 180 |
| | 506 | SHCS, M8 x 30 |
| 5327523 | 507 | Transmission key, 14 x 9 x 40 |
| | 508 | Oil block |
| | 509 | Cone roller bearing |
| | 510 | Gear stud |
| | 511 | Tab, 6 x 6 x 20 |
| | 512 | Worm pressure pad |
| | 513 | SHCS, M8 x 16 |
| | 514 | Washer, Ø8 split lock |

| | | |
|---------|-------|--------------------------------------------------------|
| 5327976 | 515 | Big size belt pulley |
| | 516 | Oil seal, Ø45 x 25 x 10 |
| | 517 | Transmission back flange |
| | 518 | Nut, M10 |
| | 519 | Washer, Ø10 split lock |
| | 520 | Nut, M8 |
| | 521 | Bearing 6028 |
| | 522 | Snap ring, Ø50 |
| | 523 | Helical gear |
| | 524 | Spline shaft |
| | 525 | Bearing 6010 |
| | 526 | HHB, M10 x 170 |
| 5327745 | 529 | Fitting, G1/8" Ø8, straight |
| 5328350 | 529 | Fitting Ø8- Ø8-G1/8" |
| 5327745 | 530 | Fitting, G1/8" Ø8, straight |
| | 531 | Inner hexangular set screw, M6 x 20 |
| | 532 | Rotary joint block inner piece |
| | 532 | Rotary joint block inner piece |
| | 533 | O-ring, Ø60 x 2.75 |
| | 534 | Rotary Valve jacket |
| | 534 | Rotary Valve jacket |
| 5327099 | 535 | Motor |
| 5328429 | 535 | Motor |
| 5328429 | 535 | Motor |
| | 535-1 | Start capacitance |
| | 535-2 | Running capacitance |
| | 536 | Locking nut |
| | 537 | Motor base weldment |
| | 538 | Nut, M8 |
| | 539 | HHB, M8 x 40 |
| | 540 | Socket flat head screw, M8 x 30 |
| 5327613 | 541 | V belt 1168 |
| 5400249 | 542 | Washer |
| | 543 | Washer, Ø10, flat |
| 5400457 | 544 | Nut, M10 |
| 5327369 | 545 | Motor pulley |
| | 546 | Inner hexangular set screw, M8 x 16 |
| | 547 | Washer, Ø8 flat |
| | 548 | Core cable |
| 5327877 | 549 | Rotary Valve fixed set of device configuration diagram |

Pedals

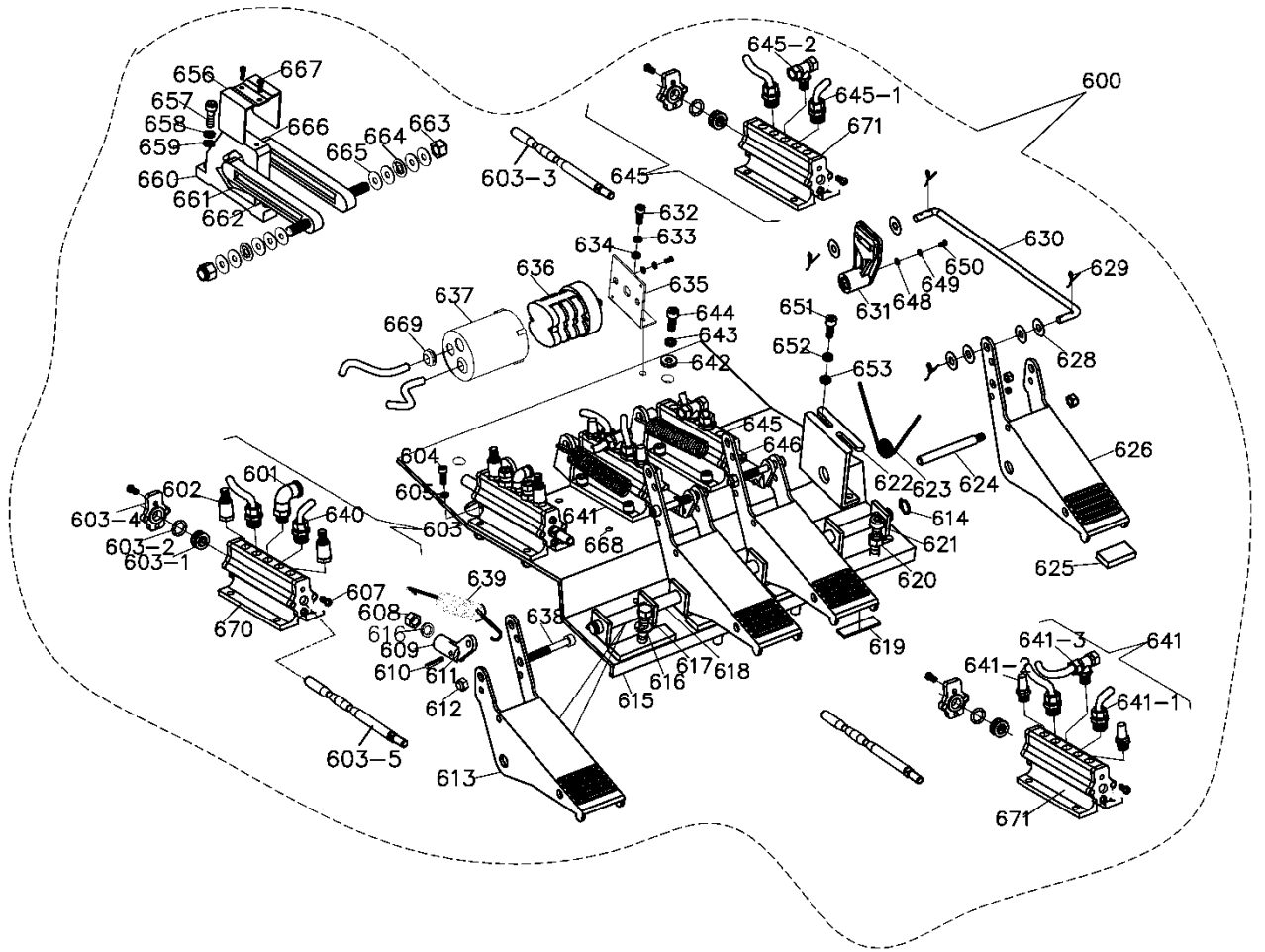

| BendPak Part # | Drawing # | Description |
|----------------|-----------|----------------------------------------|
| 5327103 | 600 | Front foot pedal assembly |
| 5400933 | 601 | Fitting, G1/8" Ø8, 90° |
| 5327545 | 602 | 1/8" Adjustable silencer |
| 5327387 | 603 | Tilt back air Valve |
| 5327482 | 603-1 | Air Valve O-ring spacer |
| 5327536 | 603-2 | O-ring, 17 x 4 |
| | 603-3 | Large cylinder Valve stem |
| 5327499 | 603-4 | Air Valve end cap |
| 5327531 | 603-5 | Valve stem |
| | 604 | SHCS, M6 x 12 |
| | 605 | Washer, M6, flat |
| | 607 | Cross recessed pan head screw, M4 x 10 |
| | 608 | Nut, M8 |
| 5327374 | 609 | Foot pedal link |
| 5327554 | 610 | Spring pin, M4 x 18 |

| | | |
|---------|-------|--------------------------------|
| 5327408 | 611 | Air Valve connecting link |
| | 612 | Locking nut M6 |
| | 613 | Foot pedal (right) |
| | 614 | Snap ring, Ø12 |
| | 615 | Base board |
| | 616 | Washer, Ø8 Split lock |
| | 617 | HHB, M8 x 16 |
| | 618 | Foot pedal shaft |
| | 619 | Control system adjusting pad |
| | 620 | Nut, M8 |
| | 621 | SHCS, M8 x 50 |
| | 622 | Torsion spring bracket |
| 5327035 | 623 | Foot pedal torsion spring |
| | 624 | Foot pedal limit rod |
| | 625 | Foot pedal rubber insert |
| 5327033 | 626 | Foot pedal (left) |
| | 628 | Spacer, Ø6 |
| | 629 | Pin, Ø3.2 x 25 |
| 5327038 | 630 | Directional switch cam linkage |
| 5400324 | 631 | Turntable direction switch cam |
| | 632 | SHCS, M6 x 12 |
| | 633 | Washer, Ø6 split lock |
| | 634 | Washer, Ø6 flat |
| | 635 | Directional switch bracket |
| 5400331 | 636 | Directional switch, 220V/40A |
| | 637 | Directional switch cover |
| | 638 | SHCS, M6 x 55 |
| 5327034 | 639 | Foot pedal return split lock |
| 5327745 | 640 | Fitting, G1/8" Ø8, straight |
| 5327385 | 641 | Jaw clamp air Valve |
| | 641-1 | Fitting, G1/4" Ø8, straight |
| | 641-2 | Silencer, G1/4" |
| | 641-3 | Fitting, Tee G1/4" Ø8 |
| | 642 | Spacer, Ø8 |
| | 643 | Washer, Ø8 split lock |
| | 644 | SHCS, M8 x 20 |
| 5327386 | 645 | Bead breaker air Valve |
| | 645-1 | Fitting, G1/4" Ø10 |
| | 645-2 | Fitting, Tee G1/4" Ø8 |
| | 646 | Cylinder retaining bush |
| | 648 | Washer, Ø5 flat |
| | 649 | Washer, Ø5 split lock |

| | | |
|---------|-----|----------------------------------------|
| | 650 | Cross recessed pan head screw, M5 x 16 |
| | 651 | SHCS, M6 x 16 |
| | 652 | Washer, M6 flat |
| 5400913 | 653 | Washer, M6 flat |
| 5327412 | 656 | Foot pedal cam cover |
| | 657 | SHCS, M6 x 20 |
| | 658 | Washer, M6 flat |
| 5400913 | 659 | Washer, M6 flat |
| 5327047 | 660 | Foot pedal cam |
| 5327048 | 661 | Foot pedal cam leaf spring (left) |
| | 662 | Foot pedal cam leaf spring (right) |
| | 663 | Locking nut, M8 |
| | 664 | Curved spring Washers, Ø8 |
| | 665 | Washer, Ø8 flat |
| 5327049 | 666 | Foot pedal cam link |
| | 667 | Cross recessed pan head screw, M3 x 10 |
| | 669 | Cable holder |
| | 670 | Air Valve (B) |
| | 671 | Air Valve (A) |

Turbo-Blast™

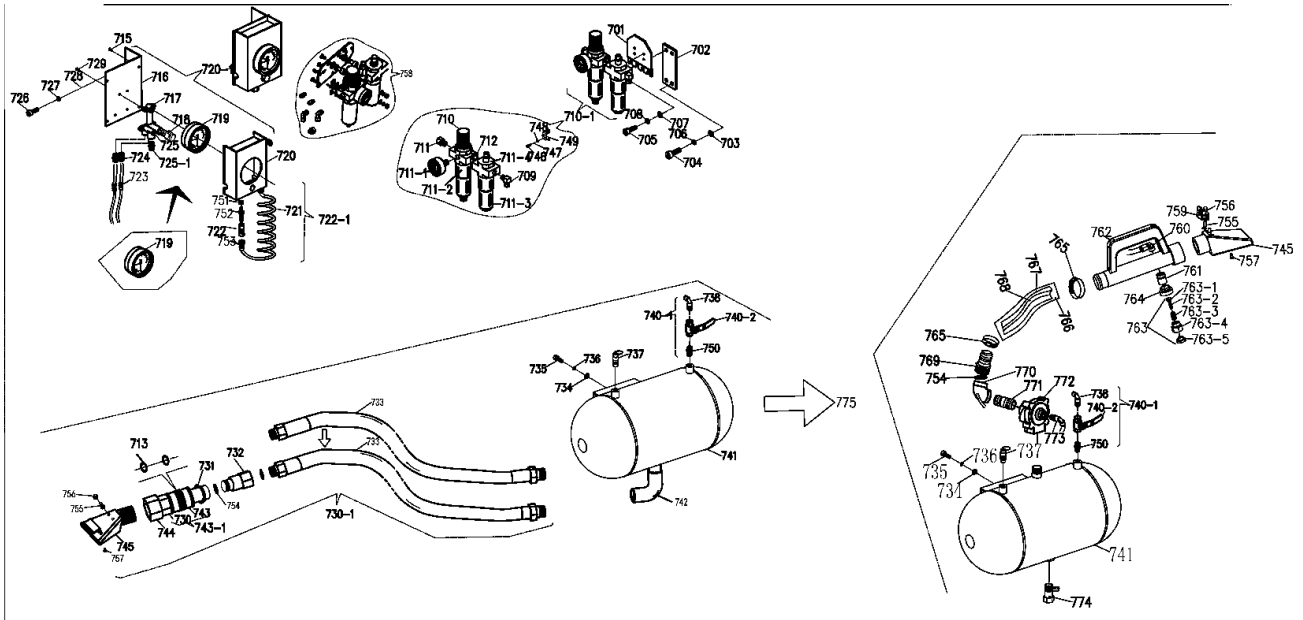

| BendPak Part # | Drawing # | Description |
|----------------|-----------|----------------------------------------|
| | 701 | Upper air/oil reg bracket |
| | 702 | Lower air/oil reg bracket |
| | 703 | Washer, Ø8 Flat |
| | 704 | SHCS, M8 x 20 |
| | 705 | SHCS, M8 x 16 |
| | 706 | Washer, Ø8 split lock |
| | 707 | Washer, Ø8 flat |
| | 708 | Washer, Ø8 split lock |
| 5400007 | 709 | Fitting, 8 mm, 1/4", 90° |
| 5327125 | 710 | Air regulator w/gauge |
| | 710-1 | Air/oil regulator assembly |
| 5327559 | 711 | Air fitting spacer |
| | 711-1 | Pressure gauge |
| | 711-2 | Filter cup |
| | 711-3 | Oiler cup |
| | 711-4 | The big cups table oil mist detector |
| | 711-4 | Air regulator w/gauge |
| 5327448 | 712 | Fitting, 1/4" Tee |
| 5327512 | 713 | Turbo blast seal kit, Ø50 x Ø 40 x 6 |
| 5326270 | 713 | O-Ring, Ø40 x 3.55 |
| | 715 | Cross recessed pan head screw, M3 x 10 |
| | 716 | Inflator assembly base |
| 5327054 | 717 | Tire inflator relief Valve |
| 5327055 | 718 | Air release Valve, G1/4" |

| | | |
|---------|-------|----------------------------------------|
| 5327769 | 719 | Inflation gauge, G1/4" |
| 5327769 | 719 | Inflation gauge (damp), G1/4" |
| 5327051 | 720 | Inflation system plastic cover |
| 5327463 | 720-1 | Tire inflator box assembly |
| 5327484 | 721 | Coiled hose, air |
| 5327130 | 721-1 | Inflation hose assembly |
| 5327538 | 722 | Air Chuck, Ø8 |
| 5327538 | 722 | Air Chuck, Ø8 |
| | 723 | Quick plug, straight Ø8- Ø8 |
| | 724 | Fitting, G1/8" Ø8 |
| | 725 | Block, G1/8" |
| | 725-1 | Tower straight in, G1/4" - G1/8" |
| | 726 | SHCS, M6 x 20 |
| | 727 | Washer, M6 flat |
| 5400913 | 728 | Washer, M6 flat |
| | 729 | Cross recessed pan head screw, M3 x 10 |
| | 730 | 1" Connector |
| 5327892 | 730-1 | Turbo blast hose assembly |
| 5327611 | 731 | M40 snap ring |
| 5327335 | 732 | Turbo blast handle / connector |
| 5327603 | 733 | Turbo blast 1" Hose |
| 5327603 | 733 | Turbo blast 1" Hose |
| 5327603 | 733 | Turbo blast 1" Hose |
| | 734 | Washer, Ø8 flat |
| | 735 | SHCS, M8 x 25 |
| | 736 | Washer, Ø8 split lock |
| 5327449 | 737 | Pressure release Valve |
| 5400931 | 738 | Fitting, 8 mm x 1/4" 90° |
| | 740-1 | Ball Valve, G1/4" assembly |
| 5327671 | 740-2 | Ball Valve, G1/4" |
| 5327460 | 741 | Air tank |
| | 741 | Air tank |
| 5400824 | 742 | Fitting, 1" elbow |
| 5324125 | 743 | Turbo Blast Valve |
| | 743-1 | Turbo Blast Valve assembly |
| | 743-1 | Turbo Blast Valve assembly |
| 5327102 | 744 | Turbo Blast nozzle adapter |
| | 746 | SHCS, M4 x 12 |
| | 747 | Washer, Ø4 split lock |
| | 748 | Washer, Ø4 flat |
| | 749 | Air/oil regulator bracket |
| | 750 | Screwed nipple, G1/4" - G1/4" |

| | | |
|---------|-------|---------------------------------------------|
| | 751 | Nut, M6 |
| | 752 | Inflation hose plug |
| | 753 | Fitting, G1/8" Ø8 |
| 5327044 | 745 | Jet blast nozzle |
| 5328445 | 745 | Blasting nozzle upper cover |
| | 755 | Cross recessed pan head screw, M6 x 12 |
| | 756 | Acorn nut, M6 |
| | 757 | Cross recessed head tapping screw, 4.2 x 13 |
| | 759 | Cross recessed pan head tapping screws |
| | 758 | Air/oil regulator assembly |
| 5328443 | 760 | Lock nut |
| | 761 | Butt joint (G1/4" - G1/8") |
| | 762 | BB blade handle cover |
| | 763 | Vent Valve |
| | 764 | Lock nut |
| | 763-1 | O-Ring |
| | 763-2 | Piston |
| | 763-3 | Spring |
| | 763-4 | Valve body |
| | 763-5 | Button |
| 5328444 | 765 | Stainless steel tube button |
| | 766 | Nylon fabric jacket |
| | 767 | PVC steel wire tube |
| | 768 | PU straight pipe |
| 5328442 | 754 | O-Ring, Ø28 X 3.55 |
| | 769 | Blasting Valve joint |
| | 770 | Elbow |
| | 771 | Butt joint, 1" |
| 5328446 | 772 | Blasting Valve |
| | 773 | Elbow, G1/4" Ø6 single |
| | 774 | Mother baby Valve |
| 5400429 | 775 | Turbo Blast assembly |

Assist Tower (R76ATR Only)

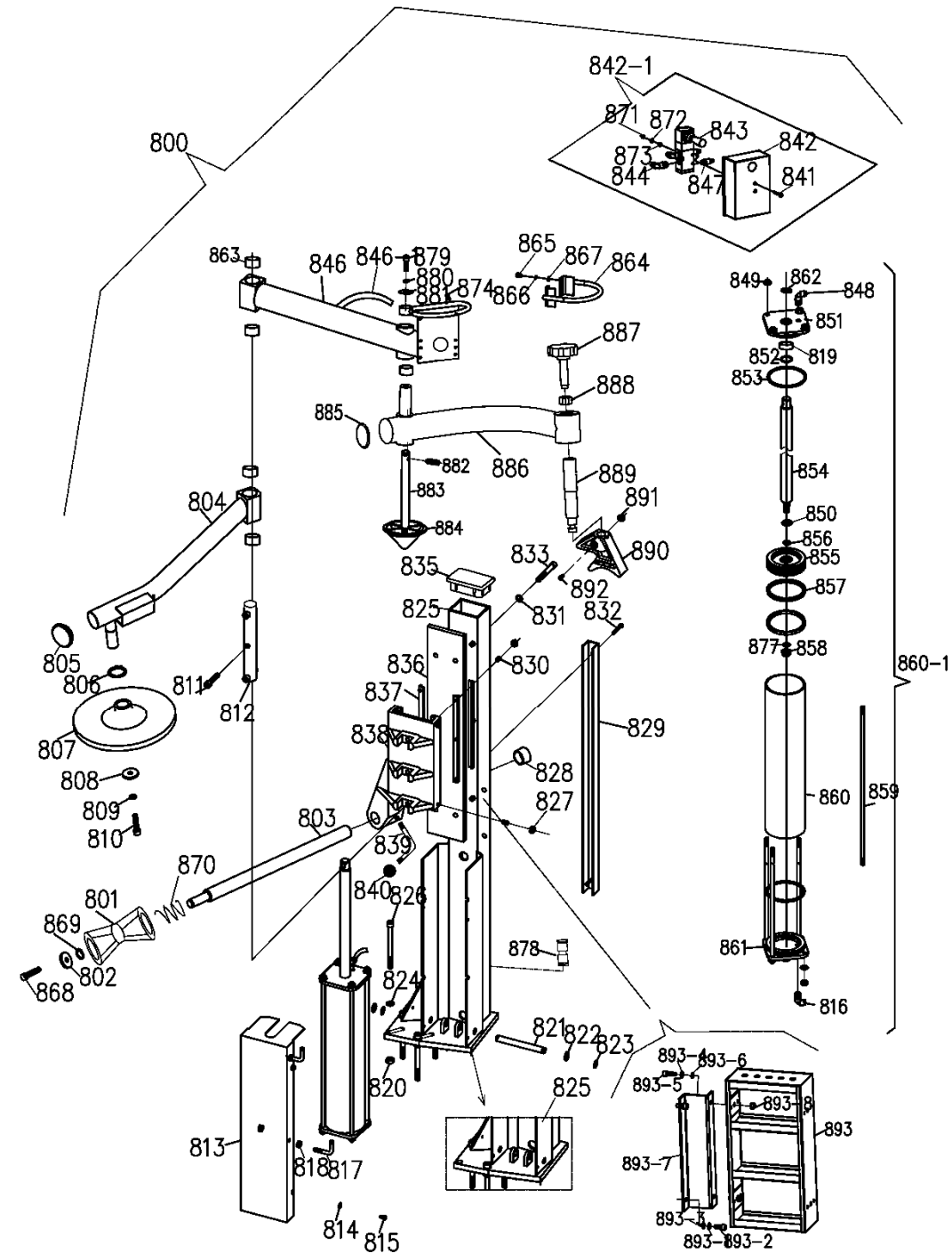

| BendPak Part # | Drawing # | Description |
|----------------|-----------|------------------------|
| | 800 | Assist in hand |
| 5327567 | 801 | Double cone BB Roller |
| | 802 | Washer, Ø20 split lock |
| | 803 | Tire pressure rod |

| | | |
|---------|-----|----------------------------------------|
| 5327607 | 804 | Left assist arm, plastic disk |
| 5327433 | 805 | Assist arm end plug |
| | 806 | Seeger ring, Ø25 |
| 5400885 | 807 | Plastic disk |
| | 808 | Snap ring |
| | 809 | Washer, Ø10 split lock |
| | 810 | SHCS, M10 x 20 |
| | 811 | SHCS, M10 x 50 |
| | 812 | Connecting shaft |
| | 812 | Connecting shaft |
| | 813 | Left assist tower cylinder cover |
| | 814 | Washer, Ø6 flat |
| | 815 | SHCS, M6 x 12 |
| | 816 | Fitting, Ø6 x 1/8" 90° |
| 5327472 | 817 | Turbo Blast hook |
| 5327884 | 818 | Nut, M8 |
| | 819 | Bearing, B2510 |
| | 820 | Nut, M10 |
| 5327432 | 821 | Assist tower lower pin |
| | 822 | Washer, Ø12 flat |
| | 823 | Snap ring, Ø12 |
| | 824 | Washer, Ø10 flat |
| | 825 | Left assist tower weldment |
| | 825 | Left assist tower weldment |
| | 825 | Left assist tower weldment |
| | 826 | SHCS, M10 x 120 |
| | 827 | Nut, M8 |
| | 828 | Tire pressure lever back cover |
| | 829 | Assist tower air hose cover |
| | 830 | Inner hexangular set screw, M8 x 16 |
| | 831 | Washer, Ø10 split lock |
| | 832 | SHCS, M6 x 40 BOC |
| | 833 | SHCS, M10 x 75 |
| 5327434 | 835 | Assist tower top plug |
| | 836 | Slide guide |
| 5327483 | 837 | Assist tower plastic slide |
| 5327483 | 837 | Assist tower plastic slide |
| 5328294 | 838 | Assist tower slide unit |
| | 838 | Assist tower slide unit |
| | 839 | Clamp handle |
| 5327651 | 840 | Assist tower lock knob |
| 5530012 | 841 | Cross recessed pan head screw, M4 x 30 |

| | | |
|---------|-------|----------------------------------------|
| 5327098 | 842 | L/R assist arm Valve cover |
| | 842-1 | Assist arm Valve control assembly |
| | 843 | Assist arm control Valve |
| 5401427 | 844 | Banjo bolt, G1/8" Ø6 single |
| 5401427 | 844 | Banjo bolt, G1/8" Ø6 single |
| | 846 | Assist tower bent arm |
| | 846-1 | Metal braided hose cover |
| | 847 | Adjustment silencer, G1/8" |
| | 848 | Fitting, Ø6 x 1/8" 90° |
| | 849 | Nut, M8 |
| | 850 | O-ring, 16 x 2.4 |
| | 851 | Cylinder front flange |
| | 851 | Cylinder front flange |
| | 852 | O-ring, Ø25 x 2.65 |
| | 852 | O-ring, Ø25 x 2.65 |
| | 853 | O-ring, Ø90 x 2.65 |
| | 854 | Left assist tower cylinder rod |
| | 854 | Left assist tower cylinder rod |
| | 855 | Assist tower cylinder piston |
| | 855 | Assist tower cylinder piston |
| | 856 | O-ring, Ø14 x 2.4 |
| | 856 | O-ring, Ø13.2 x 2.65 |
| | 857 | Y-ring, Ø82.5 x 5.3 |
| | 858 | Locking nut, M12 |
| | 859 | Cylinder connecting thread shaft |
| | 860 | Left assist tower cylinder body |
| | 860 | Left assist tower cylinder body |
| 5327388 | 860-1 | Left assist tower cylinder |
| 5327429 | 861 | Assist tower rear cylinder plate |
| | 862 | Seal ring, Ø33 x 25 x 6 |
| | 862 | Seal ring, Ø35 x 25 x 8 |
| | 863 | Bearing B3025 |
| | 864 | Assist arm handle weldment |
| | 865 | Cross recessed pan head screw, M5 x 12 |
| | 866 | Washer, Ø5 flat |
| | 867 | Washer, Ø5 split lock |
| | 868 | SHCS, M10 x 20 |
| | 869 | Washer, Ø10 flat |
| | 870 | Spring |
| | 871 | Nut, M4 |
| | 872 | Washer, Ø 4 flat |
| | 873 | Washer, Ø 4 split lock |

| | | |
|---------|-------|----------------------------------------|
| | 874 | Cross recessed pan head screw, M4 x 12 |
| | 875 | Washer, Ø12 |
| | 877 | Washer, Ø12 |
| | 878 | 8 mm to 6 mm union |
| 5530061 | 879 | SHCS, M12 x 25 |
| | 880 | Washer, Ø12 split lock |
| | 881 | Washer |
| | 882 | Roller latch, M8 x 18 |
| | 883 | Cone shaft |
| 5400890 | 884 | Assist arm cone |
| 5327979 | 885 | Assist tower bent arm plug |
| 5327582 | 886 | Presser arm weldment |
| 5328283 | 887 | Black assist top knob |
| | 888 | Nut, M18 |
| 5328279 | 889 | Screw |
| 5327075 | 890 | Assist arm block |
| | 891 | Nut, M6 |
| 5400959 | 892 | SHCS, M6 x 30 |
| 5327173 | 893 | Tool box |
| | 893-1 | Washer, Ø8 flat |
| | 893-2 | SHCS, M8 x 20 |
| | 893-3 | Washer, Ø8 split lock |
| | 893-4 | Washer, Ø8 flat |
| | 893-5 | SHCS, M8 x 25 |
| | 893-6 | Washer, Ø8 split lock |
| | 893-7 | Tool box bracket |
| | 893-8 | Nut, M8 |



1645 Lemonwood Drive
Santa Paula, CA 93060 USA