

Four-Post Alignment Lifts

Installation and Operation Manual

Manual P/N 5900162 — Revision F7 — March 2024

Models:

- HDS-14LSX
- HDS-14LSXE

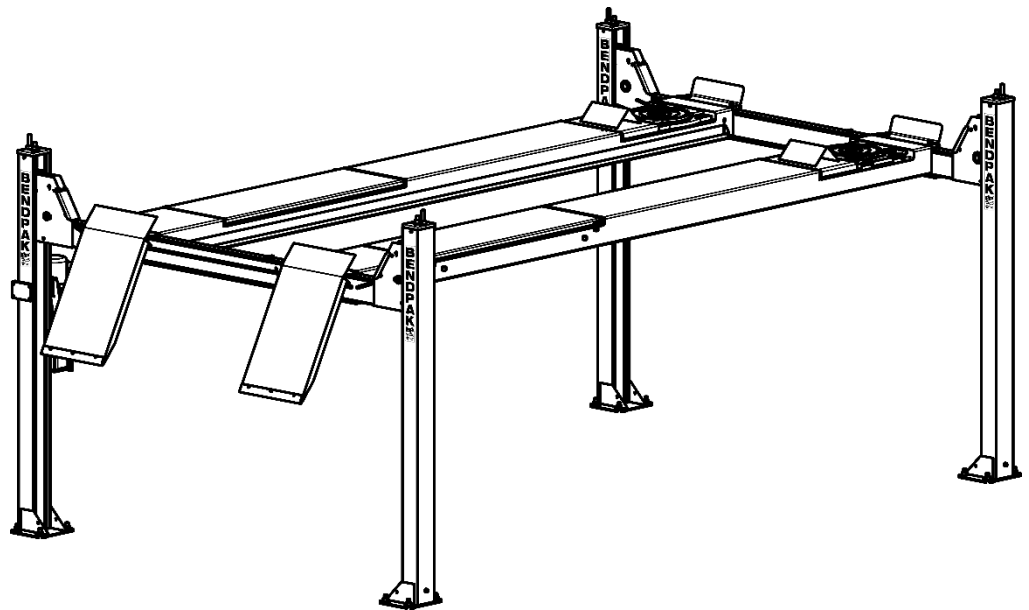

Model HDS-14LSX shown above.

*Original instructions in
the English language*

Designed and engineered by BendPak Inc. in Southern California, USA. Made in China.

 **DANGER**

IMPORTANT Safety Instructions, save these instructions! Read the *entire contents* of this manual **before using this product. Failure to follow the instructions and safety precautions in this manual can result in severe injury or death. Make sure all other operators also read this manual. Keep the manual near the product for future reference. **By proceeding with setup and operation, you agree that you fully understand the contents of this manual and assume full responsibility for product use.****

Manual – HDS-14LSX and HDS-14LSXE Four-Post Alignment Lifts, *Installation and Operation Manual*, Manual P/N 5900162, Manual Revision F7, Released March 2024.

Copyright – Copyright © 2024 by BendPak Inc. All rights reserved. You may make copies of this document if you agree that: you will give full attribution to BendPak Inc., you will not make changes to the content, you do not gain any rights to this content, and you will not use the copies for commercial purposes.

Trademarks – BendPak and the BendPak logo are registered trademarks of BendPak Inc. All other company, product, and service names are used for identification only. All trademarks and registered trademarks mentioned in this manual are the property of their respective owners.

Limitations – Every effort has been made to ensure complete and accurate instructions are included in this manual. However, product updates, revisions, and/or changes may have occurred since this manual was published. BendPak reserves the right to change any information in this manual without incurring any obligation for equipment previously or subsequently sold. All drawings are reference only – do not scale. BendPak is not responsible for typographical errors in this manual. You can always find the latest version of the **manual for your product on the BendPak website**.



SCAN FOR
DIGITAL PDF

Warranty – The BendPak warranty is more than a commitment to you: it is also a commitment to the value of your new product. Contact your nearest BendPak dealer or visit www.bendpak.com/support/warranty for full warranty details. Go to bendpak.com/support/register-your-product/ and fill out the online form to register your product (be sure to click **Submit**).

Safety – Your product was designed and manufactured with safety in mind. However, your safety also depends on proper training and thoughtful operation. Do not install, operate, maintain, or repair the unit without reading and understanding this manual and the labels on the unit; **do not use your Lift unless you can do so safely!**

Owner Responsibility – In order to ensure operator safety and maintain your product properly, it is the responsibility of the product owner to read and follow these instructions:

- Follow all setup, operation, and maintenance instructions.
- Make sure product setup and use conforms to all applicable local, state, and federal codes, rules, and regulations, such as state and federal OSHA regulations and electrical codes.
- Read and follow all safety instructions. Keep them readily available for operators.
- Make sure all operators are properly trained, know how to safely operate the unit, and are properly supervised.
- Do not operate the product until you are certain all parts are in place and operating correctly.
- Carefully inspect the product on a regular basis and perform all maintenance as specified.
- Service and maintain the unit only with approved replacement parts.
- Keep all instructions permanently with the product and make sure all labels are clean and visible. BendPak makes no promises, guarantees or assurances that our products meet any state, county, federal or international mandated permit, license, code, standard, certification, or any other mandate other than what is listed or shown on BendPak website(s), or any BendPak or Ranger online or published catalog. Not all BendPak lift models meet the standards as prescribed by ANSI/ALI ALCTV-(current edition) or ANSI/UL 201. Consult www.autolift.org for a complete list of lift models that meet ANSI/ALI ALCTV-(current edition) or ANSI/UL 201, or contact BendPak via contact@bendpak.com. Buyer assumes full responsibility for any state, county, federal or international mandated permit, license, code, standard, certification, or any other mandate required related to the installation and/or operation of any BendPak or Ranger product. BENDPAK will not be responsible for any charges, fines, liens, or other levies imposed on the Buyer related to any special or regional structural, seismic or any other building code and/or codes such as the Uniform Building Code (UBC), International Building Code (IBC), or any other state, county, federal or international mandated permit, license, code, standard, certification, or other mandate, law, rule, regulation or directive by any other agency, government, administrations, or corporations whether state, county, federal, or international mandated.

- **Only use the Lift if it can be used safely!**

Unit Information. Enter the Model Number, Serial Number, and the Date of Code from the label on your unit. This information is required for part or warranty issues.

Model: _____

Serial: _____

Date of Manufacture: _____

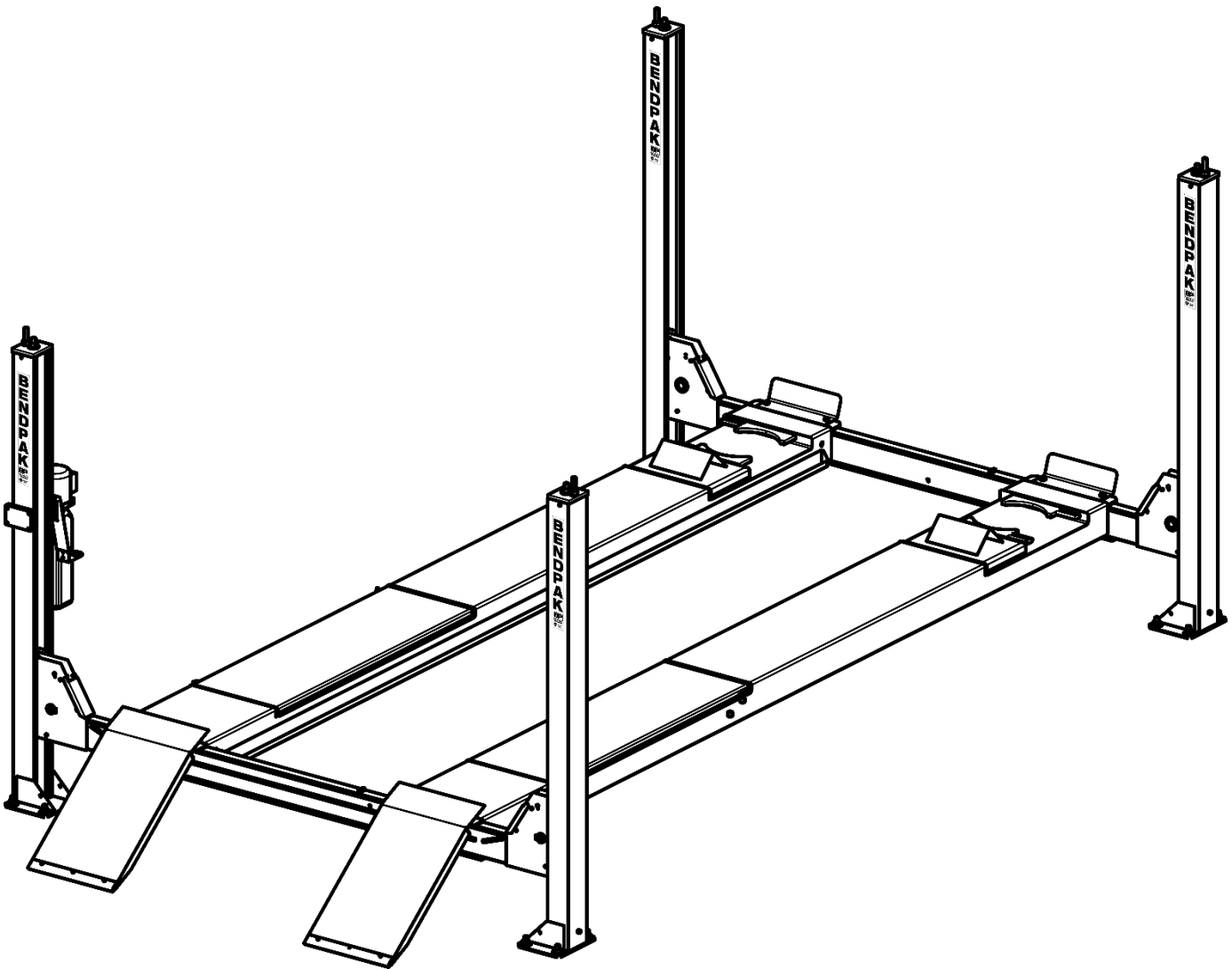

Table of Contents

Introduction	4	Installation	15
Shipping Information	5	Operation	69
Safety Considerations	5	Maintenance	72
Additional Products	8	Troubleshooting	76
Components	9	Wiring Diagrams	77
FAQs	11	Labels	78
Specifications	12	Parts Drawings	81
Installation Checklist	14	Maintenance Log	92

Introduction

This manual describes the following BendPak Four-Post Alignment Lifts:

- **HDS-14LSX:** Four-post Alignment Lift that can raise vehicles up to 14,000 pounds (6,350 kg). ALI and CE-certified.
- **HDS-14LSXE:** Four-post Alignment Lift with extended Runways that can raise vehicles up to 14,000 pounds (6,350 kg). ALI and CE-certified.

This manual is mandatory reading for all users of the HDS-14LSX and HDS-14LSXE, including anyone who installs, uses, maintains, repairs, or wants to know more about them.

⚠ DANGER Use care when installing, operating, maintaining, or repairing this equipment; failure to do so could result in property damage, product damage, injury, or (in very rare cases) death. Make sure only authorized personnel operate this equipment. An authorized technician must perform all repairs. Do not make modifications to the unit; this voids the warranty and increases the chances of injury or property damage. Make sure to read and follow the instructions in this manual and on the labels on the unit.

This manual is mandatory reading for all users of HDS-14 Series Lifts, including anyone who installs, operates, maintains, or repairs them. Always keep this manual on or near the equipment.

Technical support and service is available from your dealer, on the Web at bendpak.com/support, by email at support@bendpak.com, or by phone at **(800) 253-2363**, option 7 then 4.

Online chat is also available at www.bendpak.com click the chat icon.

Scan this QR Code for up-to-date information and videos on BendPak Lifts.



SCAN FOR VIDEO

Shipping Information

Your equipment was carefully checked before shipping. Nevertheless, you should thoroughly inspect the shipment **before** you sign to acknowledge that you received it.

When you sign a bill of lading, it tells the carrier that the items on the invoice were received in good condition. *To protect yourself, do not sign until **after** you have inspected the shipment.* If any of the items listed on the bill of lading are missing or are damaged, do not accept the shipment until the carrier makes a notation on the bill of lading that lists the missing and/or damaged goods.

If you discover missing or damaged goods **after** you receive the shipment and have signed the bill of lading, notify the carrier at once and request the carrier to make an inspection. If the carrier will not make an inspection, prepare a signed statement to the effect that you have notified the carrier (on a specific date), and that the carrier has failed to comply with your request.

It is difficult to collect for loss or damage after you have given the carrier a signed bill of lading. If this happens to you, file a claim with the carrier promptly. Support your claim with copies of the bill of lading, freight bill, invoice, and photographs, if available. ***Our willingness to assist in helping you process your claim does not make us responsible for collection of claims or replacement of lost or damaged materials.***

Read and follow the warnings and instructions on the labels on the product. Contact BendPak at **(800) 253-2363** or support@bendpak.com if you need replacement labels or a replacement manual.

Safety Considerations

Read this entire manual carefully before using your new product. Do not install or operate the product until you are familiar with all operating instructions and warnings. Refer to ANSI/ALI ALIS Standard *Safety Requirements for Installation and Service of Automotive Lifts* for more information about safely installing your Lift.

 **WARNING** **California Proposition 65.** This product can expose you to chemicals including styrene and vinyl chloride which are on the list of over 900 chemicals identified by the State of California to cause cancer, birth defects or reproductive harm. **ALWAYS** use this product in accordance with BendPak BendPak's instructions. For more information go to www.P65Warnings.ca.gov.

IMPORTANT SAFETY INSTRUCTIONS!

Save these instructions!





1. Read all instructions.
2. Care must be taken as burns can occur from touching hot parts.
3. Do not operate equipment with a damaged cord or if the equipment has been dropped or damaged – until it has been examined by a qualified service person.
4. Do not let a cord hang over the edge of a table, bench, or counter, or come in contact with hot manifolds or moving fan blades.

-
5. If an extension cord is necessary, a cord with a current rating equal to or more than that of the equipment should be used. Cords with a current rating less than the equipment may overheat. Care should be taken to arrange the cord so that it will not be tripped over or pulled.
 6. Always unplug the equipment from the electrical outlet when not in use. Never use the cord to pull the plug from the outlet. Grasp the plug and pull to disconnect.
 7. Let the equipment cool completely before putting away. Loop cord loosely around equipment when storing.
 8. To reduce the risk of fire, do not operate in the vicinity of open containers of flammable liquids (gasoline).
 9. Adequate ventilation should be provided when working on operating internal combustion engines.
 10. Keep hair, loose clothing, fingers, and all parts of body away from moving parts.
 11. To reduce the risk of electric shock, do not use on wet surfaces or expose to rain.
 12. Use only as described in this manual. Use only BendPak recommended attachments.
 13. ALWAYS WEAR SAFETY GLASSES. Everyday eyeglasses only have impact resistant lenses, they are not safety glasses.
 14. To reduce the risk of injury, close supervision is necessary when this product will be used around children.
 15. To reduce the risk of injury, **never** attempt to lift more than the rated capacity. Refer to loading instructions.
 16. The Lift uses electrical energy; if your organization has Lockout/Tagout policies, make sure to implement them after connecting the Lift to a power source.
 17. Refer to markings for proper load on electrical receptacles.
 18. Only operate your Lift between temperatures of +41°F to +104°F (+5°C to +40°C).
 19. The Lift should **only** be operated by authorized personnel. Keep children and untrained personnel away from the Lift.
 20. Do not make any modifications to the Lift; this voids the warranty and increases the chances of injury or property damage.
 21. Do not use the Lift while tired or under the influence of drugs, alcohol, or medication.
 22. Consider the work environment. Keep the work area clean. Cluttered work areas invite injuries. Keep areas well lit.
 23. **Always** make sure the Lift is secured on Safety Locks before attempting to work on or near a Vehicle.
 24. Make a thorough inspection of the product at least once a year. Replace any damaged or severely worn parts, decals, or warning labels. Replace worn or damaged parts with BendPak or BendPak approved parts and assemblies only.
 25. BendPak recommends referring to the ANSI/ALI ALIS Standard *Safety Requirements for Installation and Service* for more information about safely installing, using, and servicing your Lift.
 26. **HDS-14LSX** and **HDS-14LSXE** are Four-Post Alignment Lifts. **Use them only for their intended purpose.**
 27. You **must** wear OSHA-approved (publication 3151) personal protective equipment at all times when installing, using, maintaining, or repairing the Lift. Leather gloves, steel-toed work boots, eye protection, back belts, and hearing protection are **mandatory**.

-
28. Keep loads balanced on the Lift Arms. Clear the area immediately if a Vehicle is in danger of falling off the Lift. Do not make any modifications to the Lift.
 29. Modifications void the warranty and increases the chances of injury or property damage. *Do not modify any safety-related features in any way.*
 30. Make sure all operators read and understand this Installation and Operation Manual. *Keep the manual near the Lift at all times.*
 31. While handling a Hydraulic Cylinder or a Hydraulic Hose, **always** wear gloves. In rare cases, a needle-like stream of hydraulic fluid (even at low pressure) can penetrate fingers, hands, or arms; such a puncture can feel like a bite, electric shock, or a prick. While it may seem like a minor issue, any amount of Hydraulic Fluid injected into the human body is a serious issue. Anyone suffering such a puncture wound should be **immediately** taken to a hospital emergency room to determine the extent of the injury. Explain the circumstances of the injury to the attending physician, including what kind of Hydraulic Fluid was involved. Do not assume a puncture wound that could have been caused by Hydraulic Fluid is a minor issue; it could be life threatening.
 32. Make an inspection of the Lift **before** using it. Check for damaged, worn, or missing parts. Do not use it if you find any of these issues. Instead, take it out of service, then contact an authorized repair facility, your dealer, or BendPak **(805) 933-9970** or email support@bendpak.com.
 33. To reduce the risk of property damage, personal injury, or loss of life, **NEVER** park any vehicle on the Lift's runways without placing suitable wheel chocks behind each rear tire so that the vehicle cannot roll backward from Lift. Vehicles parked on Lift **MUST** also be placed in Park or First Gear (Manual Transmission) with the Parking Brake fully applied.

Symbols

Following are the symbols used in this manual:

- | | |
|--|--|
|  DANGER | Calls attention to an immediate hazard that will result in death or severe injury. |
|  WARNING | Calls attention to a hazard or unsafe practice that could result in death or severe personal injury. |
|  CAUTION | Calls attention to a hazard or unsafe practice that could result in minor personal injury, product damage, or property damage. |
| NOTICE | Calls attention to a situation that, if not avoided, could result in product or property damage. |
|  Tip | Calls attention to information that can help you use your product better. |

Liability Information

BendPak Inc. assumes **no** liability for damages resulting from:

- Use of the equipment for purposes other than those described in this manual.
- Modifications to the equipment without prior, written permission from BendPak.
- Injury or death caused by modifying, disabling, overriding, or removing safety features.
- Damage to the equipment from external influences.
- Incorrect operation of the equipment.

Additional Products

There are additional products you compatible with these Lifts:

- **Aligner.** An Aligner is a hardware/software product that allows wheel alignments. If you already have an Alignment Lift, like an HDS-14LSX or HDS-14LSXE, simply purchase the Aligner and you can start performing wheel alignments.

Refer to the [Aligner page on the BendPak website](#) for more information.

- **Rolling Bridge Jack.** A Rolling Bridge Jack raises the wheels of a vehicle off the Runways of a Lift, like an HDS-14LSX or HDS-14LSXE, making it much easier to perform service such as brake jobs and suspension work while the vehicle is still on the Lift.

You can raise two wheels off the Runways if you have one Rolling Bridge Jack. It takes two Rolling Bridge Jacks to raise all four wheels off the Runways.

Refer to the [Rolling Bridge Jack page on the BendPak website](#) for more information.

- **WSA-100 Air/Electric Workstation.** The Air/Electric Workstation adds air and electric capabilities to your Lift. It includes four electrical outlets and specialized air service outlets, among other features. Refer to the [WSA-100 Air/Electric Workstation page on the BendPak website](#) for more information.

Note that SKU 5210439 is optimized for the HDS-14LSX and HDS-14LSXE Alignment Lifts.

Components

The main components of your Lift include:

- **Power Post.** The Post that holds the Power Unit. **You must put the Power Post in the Rear left position** (refer to the drawing on the following page for more orientation information). You can tell the Power Post from the other Posts because it has two Mounting Brackets on it. Mount the Power Unit on one of the two Mounting Brackets.
- **The other three Posts.** These Posts are interchangeable, although their Labels are different.
- **Power Unit.** An electric/hydraulic unit that connects to an electric power source and then provides hydraulic fluid to the Hydraulic Cylinder that raises and lowers the Runways.
- **Powerside Runway.** The Runway on the same side as the Power Post. The Powerside Runway has the Hydraulic Cylinder and the Cables under it.
- **Offside Runway.** The other Runway. It does not have a Hydraulic Cylinder or Cables under it.
- **Utility Rails.** Holds the optional Rolling Bridge Jacks. Utility Rails must go on the inside of the Lift.
- **Crosstubes.** One at the front of the Lift, one at the rear. The Crosstubes are hollow; the Cables that raise and lower the Runways are routed through the Crosstubes. The Crosstubes are not interchangeable: the Front Crosstube has a small opening (called a 'Window') that faces the inside, the Rear Crosstube has a larger Window that also faces the inside of the Lift. **Windows open to the inside of the Lift only.** Cables go into the Crosstubes through the Windows.
- **Ramps.** One for each Runway. Use them to drive onto and off of the Runways.
- **Tire Stops.** Located at the Front of the Lift, Tire Stops prevent the vehicle's front tires from going any further forward. Always chock the vehicle's rear tires.
- **Turn Plates.** Movable plates that go near the Front of each Runway; required for alignments. You must orient both Runways so that their Turn Plates are at the Front of the Lift, whether you are doing alignments or not.
- **Filler Plate.** Sits next to the Turn Plate, holding it in position.
- **Slip Plate.** A large movable plate on both Runways towards the Rear of the Lift; used for alignments.
- **Safety Locks.** Once engaged, they hold the Runways in position, even if the power goes out or there is a leak in the Hydraulic Lines. Your Lift has 15 Safety Locks, spaced every four inches. This lets you lock the Lift at just the right height for what you want to do. The Lift also has a backup Slack Safety system; refer to [About Safety Locks](#) for more information. **Only leave your Lift on the ground or engaged on a Safety Lock.**
- **Pushbutton Air Valve.** Includes a pushbutton that moves the Safety Locks away from the Ladder so that they do not engage as you lower the Lift. Used to lower the Runways.
- **Ladder.** A piece of steel that gets installed at the back of each Post. Each Ladder has 15 holes in it; these are part of the Safety Lock system.
- **Aligner.** An optional, separate product that lets you perform vehicle alignments. Refer to the [aligner page on the BendPak website](#) for more information.
- **Rolling Bridge Jacks.** An optional, separate product that raises wheels of the vehicle on the Lift off the Runway, making it much easier to perform brake jobs and suspension work while the vehicle is still on the Lift. Refer to the [Rolling Bridge Jack page on the BendPak website](#) for more information.

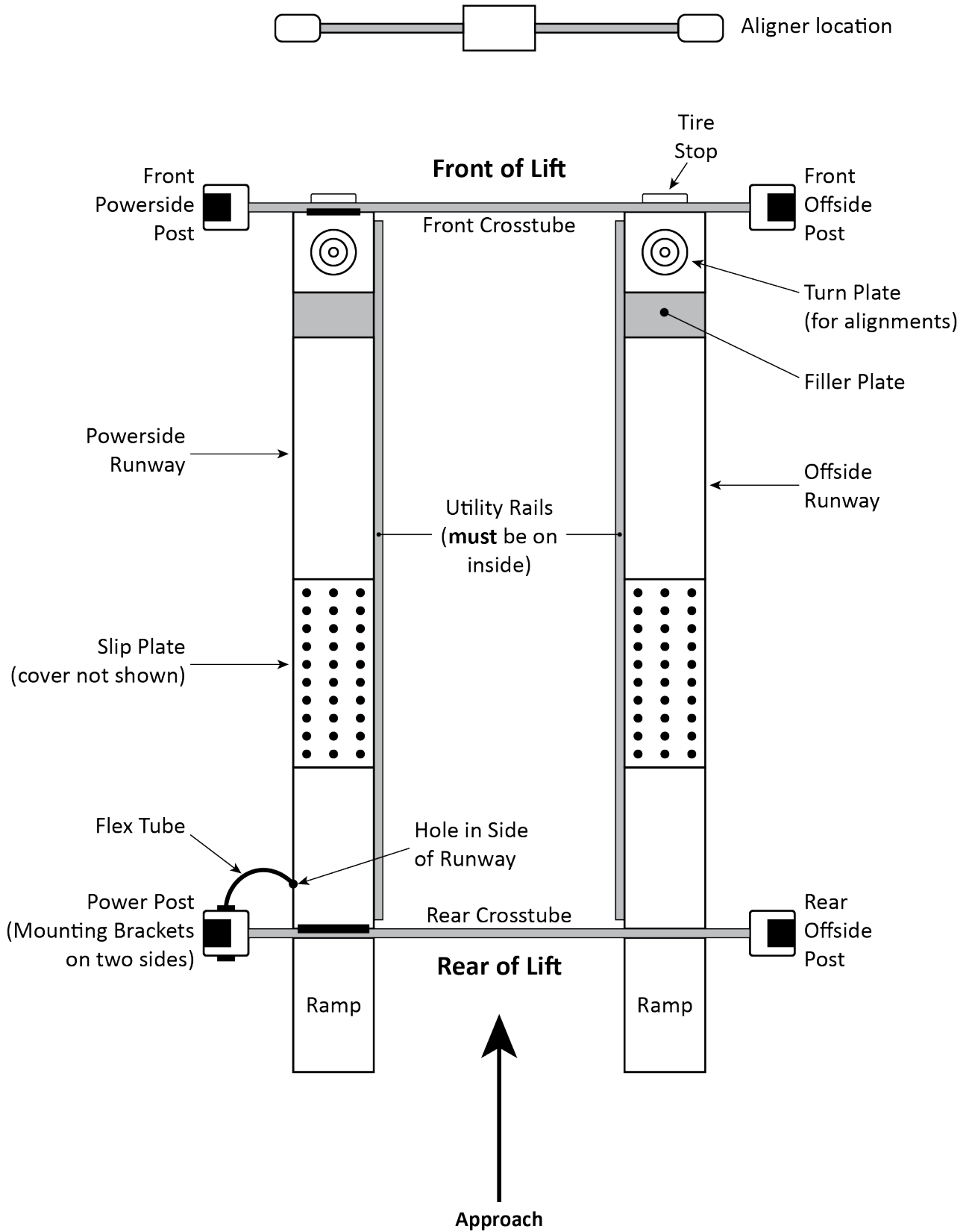

*Drawing not necessarily to scale. Some components not shown. Aligner is a separate product; it is not included with the Lift. The Front of the Lift is the end **opposite** the Ramps.*

Frequently Asked Questions

Question: What kinds of vehicles can I put on my Lift?

Answer: Cars, trucks, SUVs; anything that fits on the Runways, up to 14,000 lbs. (6,350 kg) each.

Q: What is an 'alignment' Lift?

A: A Lift with special components that allow it to be used to perform automotive alignments. The HDS-14LSX and the HDS-14LSXE are both Alignment Lifts. An alignment is an adjusting of the angles of a vehicle's wheels to the manufacturer's specifications, which generally reduces tire wear and makes the vehicle drive without pulling to one side. The HDS-14LSX and the HDS-14LSXE can also be used as Service Lifts or Parking Lifts. A Service Lift gives access to the underside of a vehicle for maintenance tasks. A Parking Lift lets you park one vehicle on the Runways and a second vehicle under the Runways.

Q: How long does it take to raise or lower my Lift?

A: About 60 seconds.

Q: Does the Lift have to be anchored in place?

A: If you are using it as an Alignment Lift, then yes, you must anchor it. If not, then it is up to you. A four-post Lift is relatively stable, but for safety reasons we recommend anchoring it.

Q: How high does the ceiling have to be?

A: It depends on the height of the vehicles you are putting on the Runways and how high you raise the Runways. If you are going to put a tall vehicle on the Lift and raise it all the way up, you should check to make sure there is enough room.

Q: Does it matter if I drive my vehicles in front first or back them in?

A: We strongly recommend driving your vehicle in front first, because that makes it easier to center the vehicle's wheels on the Runways. Also, remember to put the front wheels up against the Tire Stops and chock the rear wheels.

Q: Will the Cables really hold my vehicles?

A: Yes. Your Lift has 1/2 inch thick, aircraft-quality **wire rope** that runs through oversized sheaves, reducing friction on them and extending their life with minimal maintenance.

Q: How long can I leave a vehicle on a raised Runway?

A: As long as you want. Once the Lift is engaged on a Safety Lock, gravity holds it in position, so a loss of power does not impact it; it is going to stay where you left it. You should always leave your Lift either fully lowered or engaged on a Safety Lock.

Q: Can I install my Lift outside?

A: No. Your Lift is approved for indoor installation and use only. **Outdoor installation is prohibited.**

Q: How many Safety Lock positions does my Lift have?

A: 15, spaced every four inches.

Specifications

Top View

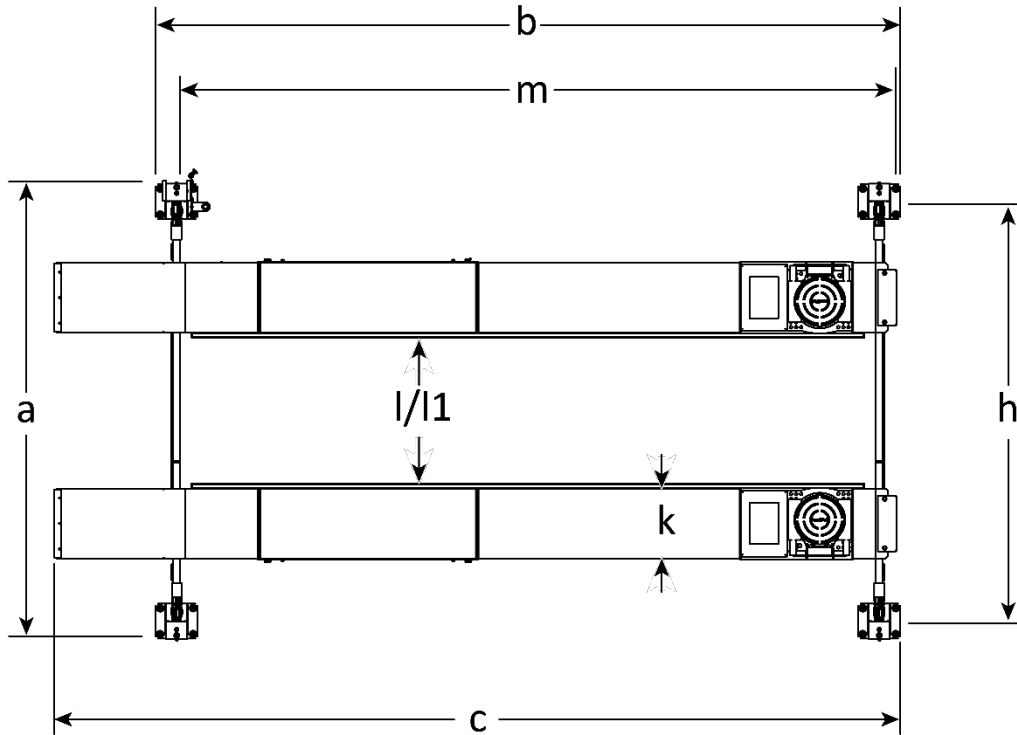

Side View

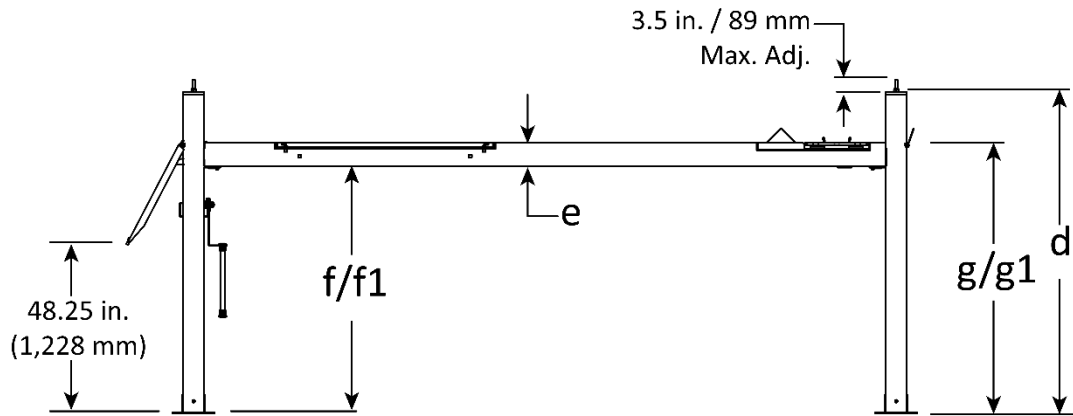

Approach View

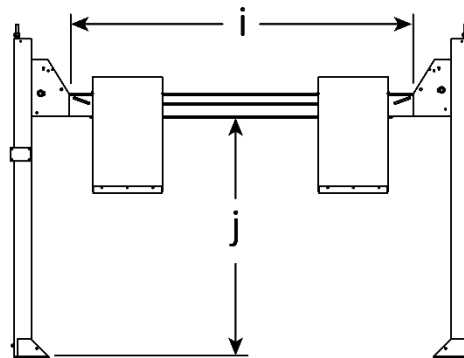

Model	HDS-14LSX	HDS-14LSXE
Lifting capacity	14,000 lbs. (6,350 kg)	
Maximum capacity front axle	7,000 lbs. (3,175 kg)	
Maximum capacity rear axle	7,000 lbs. (3,175 kg)	
a – Total width ¹	130.08 ±.125 in. (3,304 ±3.2 mm)	
b – Outside Posts length	213 in. (5,408 mm)	243 in. (6,170 mm)
c – Total length (includes ramps)	242 in. (6,146 mm)	272 in. (6,908 mm)
d – Post height (add up to 3.5 in. (89 mm) max. for Safety Ladder adjustment)	92 in. (2,338 mm)	
e – Runway thickness	6.75 in. (171 mm)	
f – Maximum rise	70.75 in. (1,799 mm)	
f1 – Max. Rise (Top Lock)	69.5 in. (1768 mm)	
g – Maximum lifting height	77.5 in. (1,970 mm)	
g1 – Max. Lifting Height (Top Lock)	76 in. (1934 mm)	
h – Distance between Posts	120 in. (3,050 mm)	
i – Drive-Thru (Width)	98.25 in. (2,498 mm)	
j – Drive-Thru (Top Lock)	68.75 (1,747 mm)	
k – Runway width	20 in. (508 mm)	
l – Width between Runways, ² min.	34.5 in. (876 mm)	
l1 – Width between Runways, ² max.	41.5 in. (1,058 mm)	
m – Runway length	197.5 in. (5,016 mm)	227.5 in. (5,778 mm)
Min 4-wheel alignment ³	89 in. (2,261 mm)	
Max. 4-wheel alignment ³	156 in. (3,962 mm)	
Max. 2-wheel alignment ³	182 in. (4,623 mm)	212 in. (5,385 mm)
Min. wheelbase @ rated capacity ⁴	140 in. (3,556 mm)	160 in. (4,064 mm)
Min. wheelbase @ 75% capacity ⁴	120 in. (3,048 mm)	140 in. (3,556 mm)
Min. wheelbase @ 50% capacity ⁴	100 in. (2,540 mm)	115 in. (2,921 mm)
Min. wheelbase @ 25% capacity ⁴	80 in. (2,032 mm)	95 in. (2,413 mm)
Locking positions	15, spaced every 4 in. (101 mm)	
Operating Pressure under Max. Load	2,250 psi	
Lifting time	60 seconds	
Regulated Air Pressure Required	50 psi at 3 cfm minimum (<i>Do not exceed 125 psi</i>)	
Motor Power Consumption Range (typical) ⁵	208 to 240 VAC, 50/60 Hz, 1 Ph, 2-3HP, 6.5 to 11 Amps	

¹ Safety Ladder fasteners add ≈30mm to the overall width. Do **not** add this 30mm to the chalk line dimensions.

² May be limited if using Rolling Bridge Jacks.

³ May vary depending on wheel size.

⁴ The Lift's rated capacity reduces with the Vehicle's wheelbase. Reducing the Vehicle's wheelbase brings the rear wheels closer to the center of the Runways, where there is less strength. For example, the maximum capacity of the Lift for a vehicle with a wheelbase of 100 in. is 50 percent (7,000 lbs.) of the Lift's rated maximum capacity.

⁵ Several different Power Units are available for this Lift. Verify actual power requirements marked on the unit delivered with the Lift. Special voltages available on request.

Specifications subject to change without notice.

Installation Checklist

Following are the steps needed to install your Lift. Perform them in the order shown.

- 1. Review the installation safety rules.
- 2. Make sure you have the necessary tools.
- 3. Plan for electrical work.
- 4. Select the installation location.
- 5. Unload and unpack the Lift components.
- 6. Create Chalk Line Guides.
- 7. Move the Posts into position.
- 8. Install the Crosstubes.
- 9. Install the Ladders.
- 10. Raise the Crosstubes
- 11. Secure the Ladders.
- 12. Install the Runways.
- 13. Install the first end of the Flex Tube.
- 14. Install the Return Line.
- 15. Install the Air Lines.
- 16. Hydraulic Fluid Contamination.
- 17. About Thread Sealants.
- 18. Install the Hydraulic Hose.
- 19. Route the Cables.
- 20. Install the Power Unit.
- 21. Install the second end of the Flex Tube.
- 22. Install the Pushbutton Air Valve and connect the Air Line.
- 23. Connect the Return Line.
- 24. Connect the Hydraulic Hose.
- 25. Contact the Electrician.
- 26. Connect to a power source (**Electrician required**).
- 27. Install the Power Disconnect Switch and Thermal Disconnect Switch (**Electrician required**).
- 28. Anchor the Posts.
- 29. Perform final leveling.
- 30. Install the Accessories.
- 31. Lubricate the Lift.
- 32. Bleed the Hydraulic Cylinder.
- 33. Perform an operational test.
- 34. Review the final checklist.
- 35. Leave the manual for the owner/operator.

Installation

The installation process takes multiple steps. Perform them in the order listed. **Read the entire Installation section before beginning the install**; this gives you a better understanding of the process as a whole.

 **WARNING** **Only use the factory-supplied parts that came with your Lift.** If you use parts from a different source, you void your warranty and compromise the safety of everyone who installs or uses the Lift. If you are missing parts, visit bendpak.com/support or call **(800) 253-2363**, select option 7 then 5.

Safety

While installing this equipment, your safety depends on proper training and thoughtful operation.

 **WARNING** Do not install this equipment unless you have automotive Lift installation training. Always use proper lifting tools, such as a Forklift or Shop Crane, to move heavy components. Do not install this equipment without reading and understanding this manual and the safety labels on the unit.

 **WARNING** Many of the Lift components are heavy and awkward to work with. Installation should be accomplished by competent personnel ensuring all heavy components are properly rigged and balanced for lifting. Installation personnel should have knowledge, training, and experience in lifting, rigging, and securing heavy objects.

Only fully trained personnel should be involved in installing this equipment. Pay attention at all times. Use appropriate tools and lifting equipment. Stay clear of moving parts.

BendPak recommends referring to the latest version of the ANSI/ALI ALIS Standard (R2015) *Safety Requirements for Installation and Service* for more information about safely installing, using, and servicing your Lift.

 **WARNING** You **must** wear OSHA-approved (publication 3151) personal protective equipment at all times when installing, using, maintaining, or repairing the Lift: leather gloves, steel-toed boots, eye protection, back belts, and hearing protection are **mandatory**.

Tools

You may need some or all of the following tools:

- Rotary hammer drill (or equal)
- ¾ inch carbide bit (conforming to ANSI B212.15)
- Hammer and crow bar
- Four-foot level
- Open-end wrench set, SAE, and metric
- Socket and ratchet set, SAE, and metric
- Hex key wrench set
- Medium crescent wrench, torque wrench, pipe wrench
- Chalk line
- Medium-sized flat screwdriver and needle-nose pliers
- Tape measure (25 feet or above)
- Forklift, shop crane, or heavy-duty rolling dolly, and two sawhorses
- 12-foot ladder

Planning for Electrical Work

A licensed Electrician must be available at some point during the installation.

 **DANGER** A licensed Electrician must perform all wiring.

Notify your Electrician in advance so that they come prepared with an appropriate cable for connecting to the power source, a plug for the Power Unit, a Power Disconnect Switch, and a Thermal Disconnect Switch. Refer to [Contacting the Electrician](#) for more information.

The Electrician needs to:

- **Connect an electric power source to the Power Unit.** An electrical power source is required. The Electrician will install an appropriate plug to the wiring on the Power Unit and provide a power cable from the power source to the Power Unit.
- **Install a Power Disconnect Switch.** Ensures you can quickly and completely interrupt electrical power to the Lift in the event of an electrical circuit fault, emergency, or when equipment is undergoing service or maintenance. Put it within sight and reach of the Lift operator.
- **Install a Thermal Disconnect Switch.** Ensures the equipment shuts down in the event of an overload or an overheated motor.

Selecting a Location

When selecting the location for your Lift, consider:

- **Architectural plans.** Consult the architectural plans for your desired installation location. Make sure there are no issues between what you want to do and what the plans show.
- **Power.** You need a 220 VAC power source available for the Power Unit. Electrical current requirements will vary with the power unit supplied. Refer to the electrical data plate on the power unit for specific wiring and current requirements.

 **DANGER** Risk of explosion: The Power Unit has internal arcing or parts that may spark and should not be exposed to flammable vapors. Motor should not be located in a recessed area or below floor level. Never expose the Power Unit motor to rain or other damp environments. Damage to the motor caused by water is **not** covered by the warranty.

- **Outdoor installations.** Your Lift is approved for indoor installation and use only. Outdoor installation is prohibited.
- **Floor.** Only install the Lift on a flat, concrete floor; do not install on asphalt or any other surface. The surface must be level; do not install if the surface has more than three degrees of slope.

 **WARNING** Installing your Lift on a surface with more than three degrees of slope could lead to injury or even death. Only install the Lift on a level floor (defined as no more than 3/8 of an inch difference over the installation area). If your floor is not level, consider making the floor level or using a different location.

- **Shimming.** If your concrete floor is not completely level, you can use Shims under the bases of the Posts, to level the Lift.

NOTICE Because your Lift is an Alignment Lift, you want to **make it as level as possible**. You can level you Lift in two ways: first, by shimming the Posts and second by adjusting the Nuts at the top of the Ladder. Both methods are covered in the

installation instructions, shimming near the beginning of the install, adjusting towards the end.

To estimate your Shim requirements, use a transit level and targets to check for flatness. Use the provided Shims, as necessary.

NOTICE Do not shim a Post more than half an inch using the provided Shims and Anchor Bolts. A maximum shim of 2 inches is possible by ordering optional Shim Plates. Contact BendPak at **(800) 253-2363**, select option 7 then 5 to order. Please have the model and serial number of your Lift available.

- **Concrete specifications.** Do not install the Lift on cracked or defective concrete. Make sure the concrete is at least 4.25 inches thick, 3,000 PSI, steel reinforced, and cured for a minimum of 28 days.

CAUTION BendPak lifts are supplied with installation instructions and concrete anchors that meet the criteria set by the American National Standard “Automotive Lifts – Safety Requirements for Construction, Testing, and Validation,” ANSI/ALI ALCTV. You are responsible for any special regional structural and/or seismic anchoring requirements specified by any other agencies and/or codes such as the Uniform Building Code (UBC) and/or International Building Code (IBC).

Be sure to check your concrete floor to determine if it is a **post-tension slab**. In this case, you must contact the building architect or the local building and safety department before drilling. Using ground penetrating radar may be required to find the tensioned steel.

WARNING Cutting through a tensioned cable can result in injury or death. Do not drill into a post-tension slab unless the building architect confirms you are not going to hit tensioned steel, or you have located it using ground penetrating radar. **If a colored sheath comes up during drilling, stop drilling immediately.**

If the existing concrete floor does not meet the minimum requirements **BendPak strongly recommends consulting a Concrete Specialist early in your planning process for the Lift installation.** The recommendations presented in this manual are generic in nature and cannot cover all situations. A Concrete Specialist will adjust these recommendations to account for national, state, and local building codes as well as local weather conditions, soil composition, base preparation, load bearing, seismic requirements and any other structural concerns that may arise.

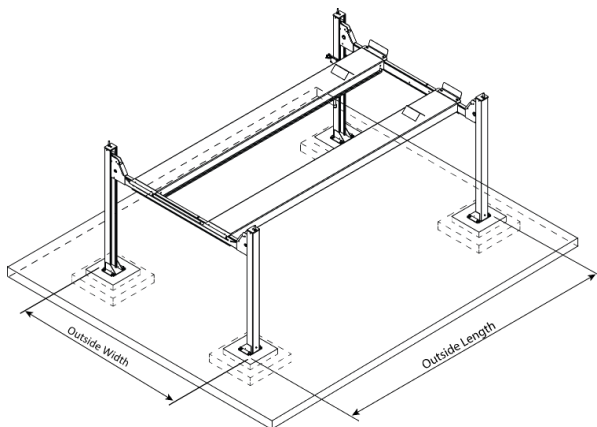

- **Available space.** Make sure there is enough space for the Lift: front, back, sides, and above. Refer to **Specifications** for measurements.
- **Overhead obstructions.** Check for overhead obstructions such as building supports, heaters, electrical lines, low ceilings, hanging lights, and so on. **You do not want the vehicles on the**

Lift hitting obstructions. As a general rule, the Lift location should have 92 inches of height for the Lift posts, plus the height of the tallest vehicle you plan to lift.

- **Side and front clearances.** You must leave room around the Lift. Leave at least five feet (60 inches) clear on each side, three feet (36 inches) clear on the Front of the Lift (you will need more for the alignment equipment if you have an Aligner), and no obstructions at all at the Rear of the Lift (so you can safely drive vehicles onto the Runways).

Clearances

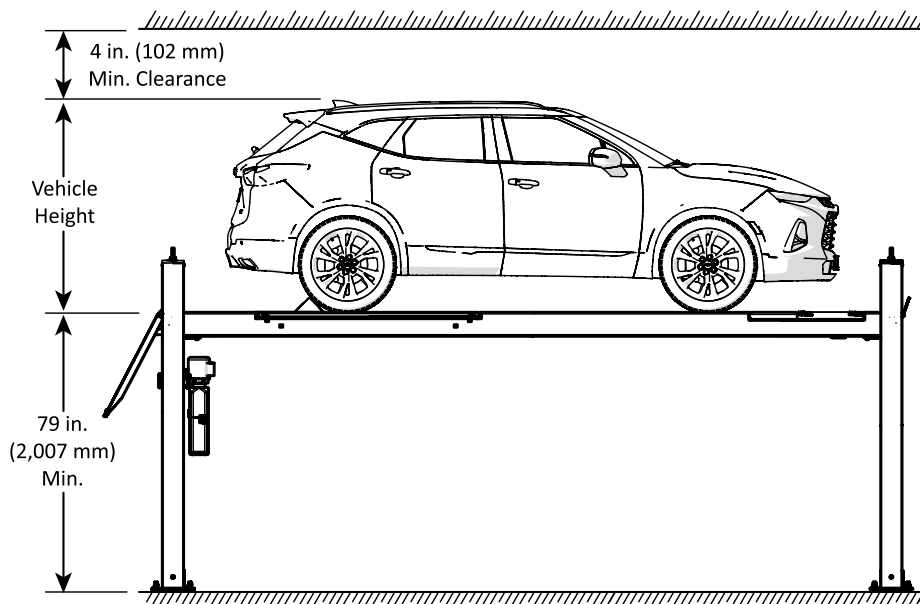
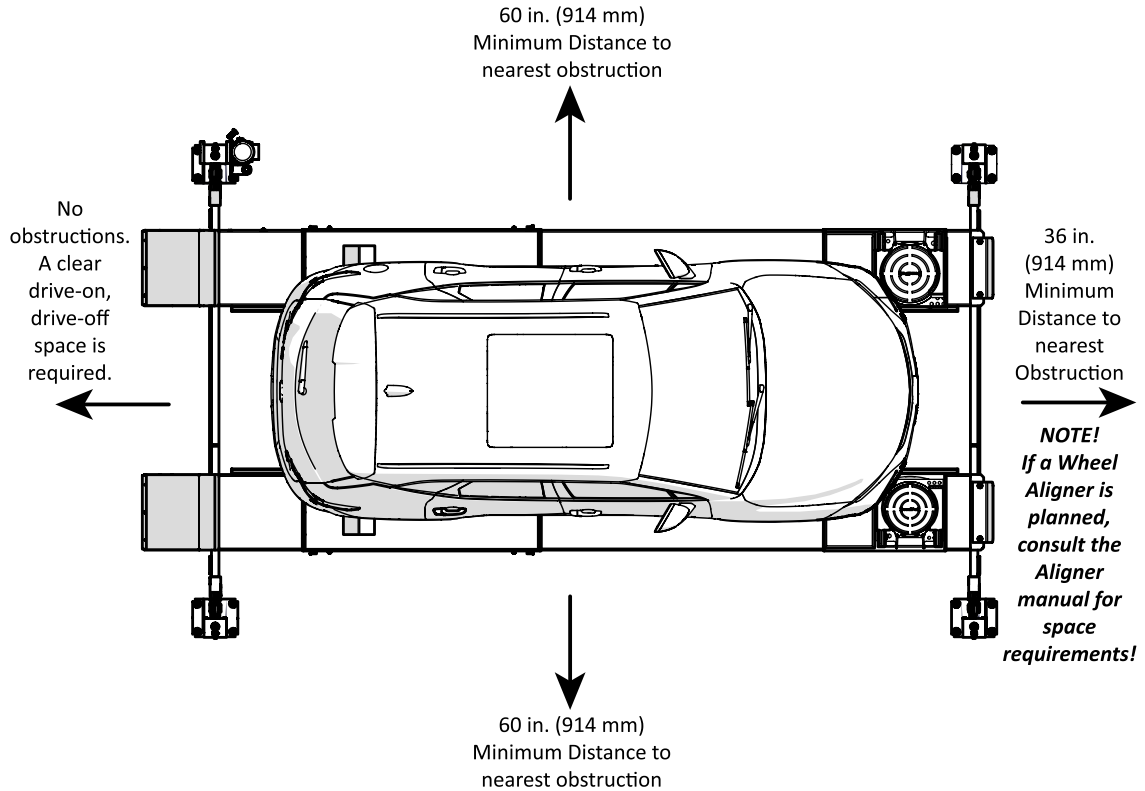

Unloading and Unpacking

Try to have the components of the Lift unloaded near the installation location.

Once the components are unloaded, they are your responsibility to move around. As the Lift includes a number of heavy pieces, the closer you unload them to the installation location, the better off you are.

 **CAUTION** Some Lift components are very heavy; if handled incorrectly, they can damage materials like tile, sandstone, and brick. Try to handle the Lift components twice: once when delivered and once when moved into position. You must have a Forklift or Shop Crane to move them into position. Use care when moving them.

 **WARNING** The Posts and Runways are delivered with stabilizing structures on each end. Be very careful when removing these stabilizing structures; the Posts and Runways can shift or even fall. If they fall on a person, they could cause severe injury.

Creating Chalk Line Guides

Use Chalk Line Guides to ensure that your Posts get installed correctly.

Create the Chalk Line Guides so that the outside edges of all four Post bases fit into the four corners created by the Chalk Line Guides.

Refer to **Specifications** to determine the **Total Width** and **Outside Posts Length** values for your Lift.

Note: Do **not** use the Total Length value; this includes the Ramps, which are not taken into consideration for creating Chalk Line Guides.

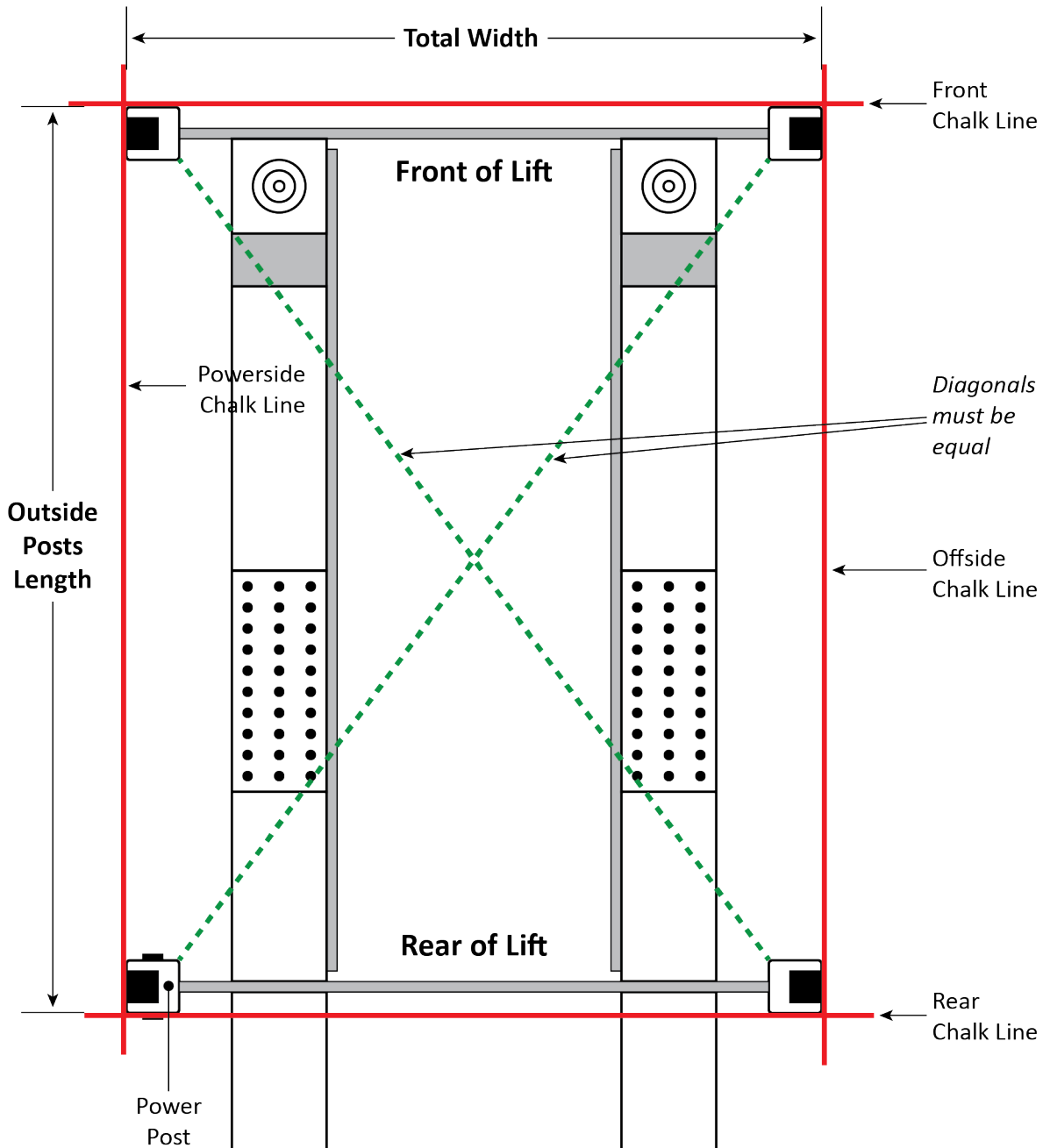

To create Chalk Line Guides:

1. Create the Front Chalk Line where you want the Front of the Lift.

Make the Front Chalk Line longer than the Total Width setting for your Lift model.



Tip

If you are going to be using the Lift to do alignments, leave room at the Front of the Lift for the alignment equipment.

2. Create the Powerside and Offside Chalk Lines at 90° angles to the Front Chalk Line and parallel to each other. Make the Powerside and Offside Chalk Lines longer than the Outside Posts Length setting for your Lift model.

The Powerside and Offside Chalk Lines must be parallel to each other.

Measure to verify that this is true.

3. Create the Rear Chalk Line parallel to the Front Chalk Line. Make the Rear Chalk Line longer than the Total Width setting for your Lift model.

The Front and Rear Chalk Lines must also be parallel to each other.

Measure to verify that this is true.

4. Before moving the Posts into position, measure **diagonally** to make sure the two diagonal measurements are the same. This ensures your layout is correct.

Do not forget to check the diagonals.

5. When you move the Posts into position, put the outside edges of the bases inside the corners created by the Chalk Line Guides.

Move the Posts into Position

Use a Forklift or Shop Crane to move the Posts. You need to have at least two people work together to stand up the Posts.

 **DANGER** The Posts are heavy and awkward; be very careful when handling them. If they fall on a person, they will cause injury.

To move the Posts into position:

1. Using a Forklift or Shop Crane, move the four Posts, one at a time, to the inside corners of the Chalk Line Guides.

Important: Position the Power Post at its **required** location. The other three Posts can go at any of the remaining Post locations.

2. Stand up each Post. Have at least two people work together to stand up a Post.

 **CAUTION** Use caution when walking around the Posts; they are not anchored down at this point, so it is possible to knock them over, which could cause injury.

3. Use a Transit Level to estimate the Shim requirements: use a target to find the difference in height between the Posts. The difference is the estimated amount of Shim thickness you will need.

Do not use Shims and/or Anchor Bolts to Shim more than half an inch. You can order 2 inch Shim plates for extreme cases.

4. **Do not anchor the Posts at this point.**

Install the Crosstubes

Your Lift has two Crosstubes:

- **Front Crosstube:** Has the Small Window, where two Cable Sheaves go. Located at the Front of the Lift, with the Window facing the inside.
- **Rear Crosstube:** Has the Large Window, where four Cable Sheaves go. Located at the Rear of the Lift, with the Window facing the inside.

Both Crosstubes are hollow, which allows the Cables to be run through them to the Posts.

The following drawing shows both Crosstubes and additional components.

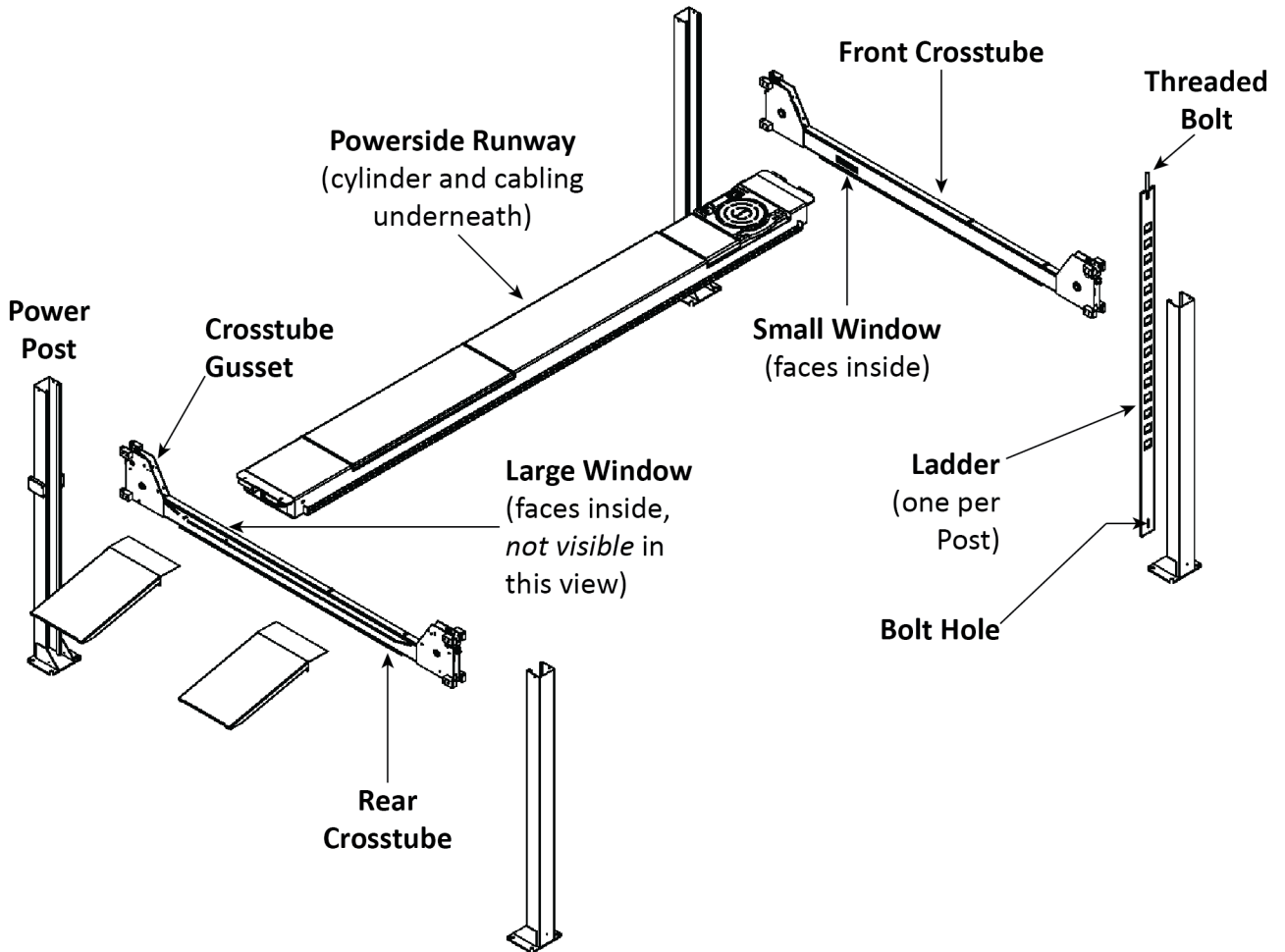

Drawing not necessarily to scale. Some components not shown. Offside Runway removed for clarity.

Crosstubes have a Crosstube Gusset on both ends.

To install the Crosstubes:

1. Orient the Crosstubes in their required locations:
 - The Front Crosstube must be at the Front of the Lift with the Small Window facing the inside.
 - The Rear Crosstube must be at the Rear of the Lift with the Large Window facing the inside.Both Windows must be on the Powerside.

The Crosstubes **must** be installed in these orientations.

2. Put black Slide Blocks into place on the outside ends of each Gusset (4 Slide Blocks per Gusset, 8 per Crosstube, 16 total for the Lift).

Align the holes in the Slide Blocks with the rods on the sides of the Gusset, then press the Slide Blocks in. Make sure the Slide Blocks are oriented so that they create a Slot when pushed in.

The following drawing shows how to correctly install two Slide Blocks onto a Gusset.

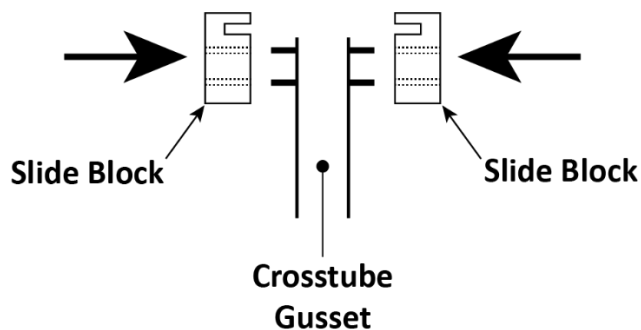

The four Slide Blocks on a Gusset, when put into place, create two Slots about four inches wide and half an inch deep. There is one Slot at the top of the Gusset and a second Slot at the bottom; the Ladder **must** go through **both** Slots on the Gusset.

- ⚠ WARNING** If the Slide Blocks are not correctly installed, then the Slots for the Ladder are not created. In such a case, the Safety Locks will not work correctly, which endangers everyone who uses the Lift. Make sure to correctly install the Slide Blocks.

The following drawing shows the Slot created by two Slide Blocks.

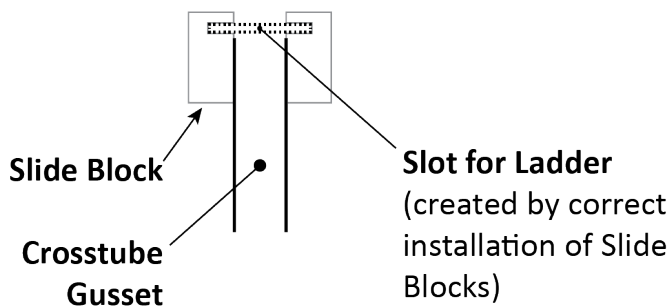

3. Using a Forklift or Shop Crane, raise the Crosstube with the Slide Blocks installed above the top of the two Posts that it goes between, lower it to just over the top of the Post, orient the Slide Blocks over the openings in the Posts, then slide the Crosstube down.
4. Perform Steps 2 and 3 for the second Crosstube.

About Safety Locks

Safety Locks hold the Runways in place. Once engaged, Safety Locks hold the Runways in place, even if the power goes out or the Hydraulic Hoses break or leak. Your Lift has 15 Safety Locks, spaced every four inches. Each Post has its own Safety Lock mechanism, for a total of four for the Lift.

Important: Simply raising the Runways does not necessarily engage them on the Safety Locks. You must back the Runways down onto the Safety Locks to engage them.

⚠ WARNING Safety Locks are dependent on correct installation of the 'Ladders.' Pay careful attention when installing the Ladders, thus ensuring correct operation of the Safety Locks on your Lift.

The Ladders, one per Post, are steel pieces with holes spaced every four inches. As you raise the Runways, the Safety Locks move into the holes in the Ladder. When you move the Runways back down a little after passing a Safety Lock, the Safety Lock engages. Once they are engaged, Safety Locks stay engaged until you are ready to lower the Runways. Even if the power goes out or one of the Hydraulic Lines breaks or leaks, the engaged Safety Locks hold the Runways in place.

⚠ WARNING Always leave the Runways either fully lowered or engaged on their Safety Locks. When you engage the Safety Locks at a desired height, check to make sure that all four Safety Locks (one per Post) are engaged.

So how do the Runways come down if the Safety Locks are engaged? To lower the Runways, you raise them a few inches (to get them off the Safety Locks), then *press and hold down* the pushbutton on the Pushbutton Air Valve. While you hold down the pushbutton, the Safety Locks are moved away from the Ladders; they cannot engage, which allows the Runways to be lowered.

Out of an abundance of caution, your Lift has a second, independent Safety Lock system called the Slack Safety. In total, your Lift has two Safety systems:

- **Safety Locks:** The primary system to hold up the Runways on your Lift are the Safety Locks. When you move the Runways up, you can hear clicks as the Safety Locks go into the holes in the Ladders. When you want to keep the Runways at a certain height, you go slightly past the height you want, then back the Safety Locks down in to the holes in the Ladders, which engages them.
- **Slack Safety:** The Slack Safeties are next to the Safety Locks on the ends of the Crosstube Gussets. They are different from the Safety Locks in that when the Cables are taut (which they are during normal operation), they hold the Slack Safeties away from the Ladder so that the Slack Safeties cannot engage. However, if a Cable were to break (which very rarely happens), the Slack Safety for the broken Cable immediately engages, preventing the Runways from falling.

Install the Safety Ladders and Top Cap

Your Lift has four Ladders (one per Post); each gets installed on the inside back of a Post. Ladders are secured at the top and the bottom.

The Top Caps secure the Ladder at the top of each Post and hold the ends of the Cables.

Note: It is much easier to secure the bottom of the Ladders once the Crosstubes have been raised, so that portion of installing the Ladders is described in [Securing the Ladders](#).

Each Ladder has 15 holes in it, spaced four inches apart; these holes are the Safety Locks. Each Ladder has a Bolt Hole at the bottom and a Threaded Bolt at the top.

⚠ WARNING Make sure to install the Ladders correctly. If they are not installed correctly, the Safety Locks on your Lift may not hold the weight of a vehicle, putting anyone under the Lift in danger.

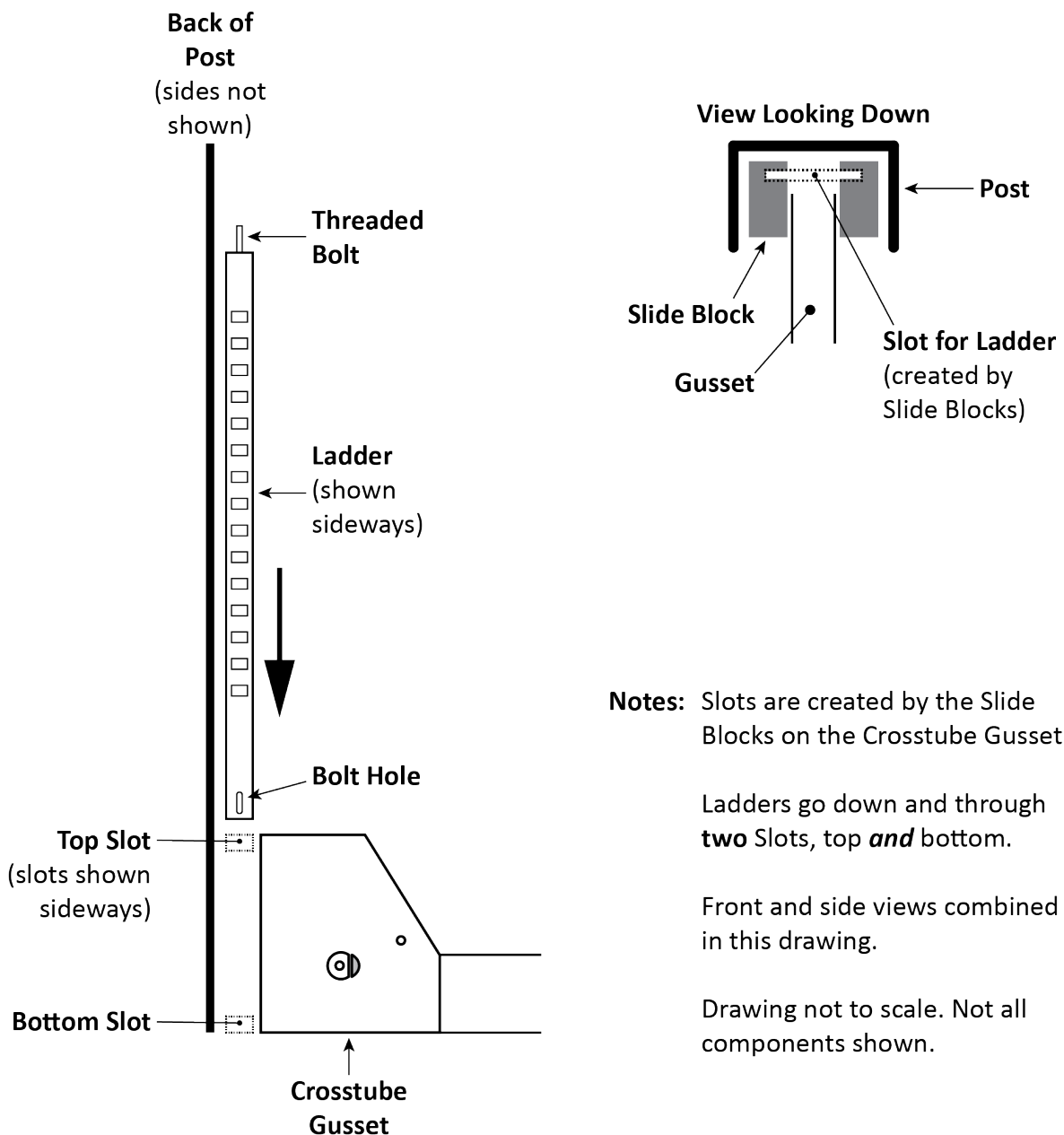

Notes: Slots are created by the Slide Blocks on the Crosstube Gusset.

Ladders go down and through **two** Slots, top **and** bottom.

Front and side views combined in this drawing.

Drawing not to scale. Not all components shown.

To install the Ladders and the Top Cap:

1. Take a Ladder and slide it down the back of the Post, Bolt Hole end at the bottom; see the drawing on the previous page.

Make sure the Ladder goes through both Slots on each Gusset. There is a Slot at the top of the Gusset and another Slot at the bottom of the Gusset, formed by the Slide Blocks.

If the Ladder misses a Slot or the Slide Blocks were not installed correctly, your Safety Locks will **not** function correctly.

⚠ WARNING Make sure that all four Ladders go through both Slots on their Gussets. If the Ladders are not installed correctly, the Safety Locks on your Lift may not hold the weight of a vehicle. If the vehicle were to fall, it could cause significant injury to anyone underneath it.

2. Install the other three Ladders the same way.
3. For each Ladder, put a Stop Nut on the Threaded Bolt at the top; move it half of the way down towards the top of the Ladder.
4. Put a Top Cap onto the top of the Post, securing it on the sides with one Hex Head Bolt and one Nyloc Nut on each side of the Top Cap.
5. Once the Top Cap is secure, move the Stop Nut up until it contacts the underside of the Top Cap, then add a Flat Washer and Nyloc Nut to the top of the Top Cap and tighten it. Only hand tighten at this point.

You are looking for about an inch of thread above the top of the Top Nut.

Note: The other hole in the Top Cap is for the Cable that is routed to the top of the Post, which is done later in the installation.

6. Install the other three Top Caps in the same manner.

Raise the Crosstubes

You need to manually raise the Crosstubes, which makes it easier to complete the rest of the installation tasks. Both Crosstubes need to be raised the same amount, to the same Safety Lock.

To raise the Crosstubes:

1. Using a Forklift or Shop Crane, carefully raise each Crosstube.

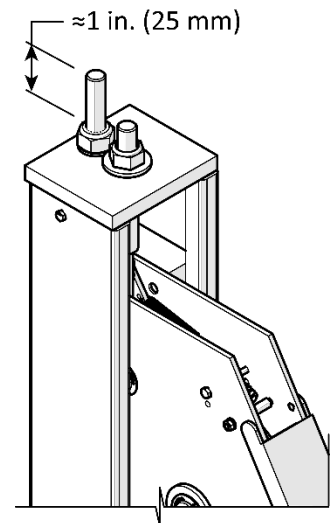
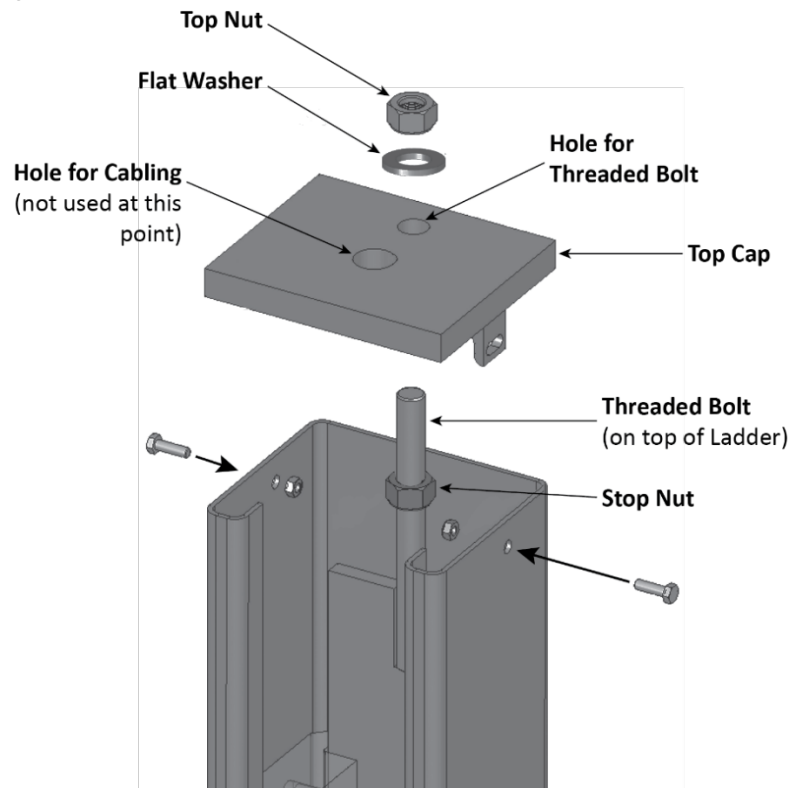

You probably want to raise the Crosstubes at least two feet off the ground, but it is up to you. Many people move it up enough to work under it, which makes it easier to route the Cables, Return Line, Air Lines, and Hydraulic Hose.

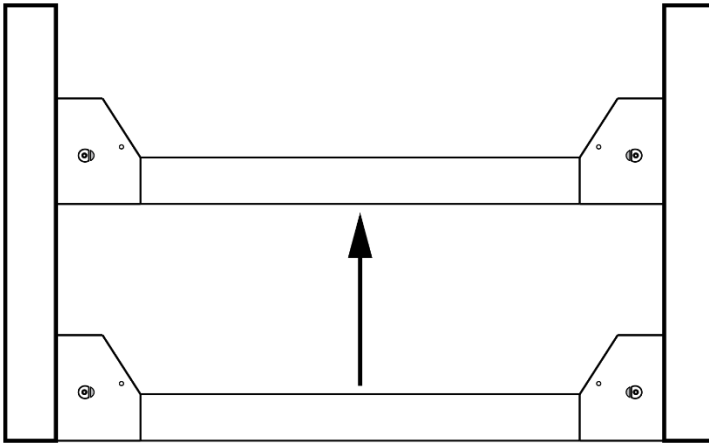

Important: The Slack Safeties cannot be engaged as you continue with the installation. Because the Cables are not in place yet, the Slack Safeties are going to engage when you manually raise the Crosstubes. You need to disengage them after you have raised the Crosstubes. The Primary Safeties are not impacted; they will engage normally when you manually raise each Crosstube, which is what you want.

2. To disengage the Slack Safeties after raising a Crosstube, press the Sheave and/or the Steel Piece (they are connected and will move together) back towards the Ladder and the back of the Post.

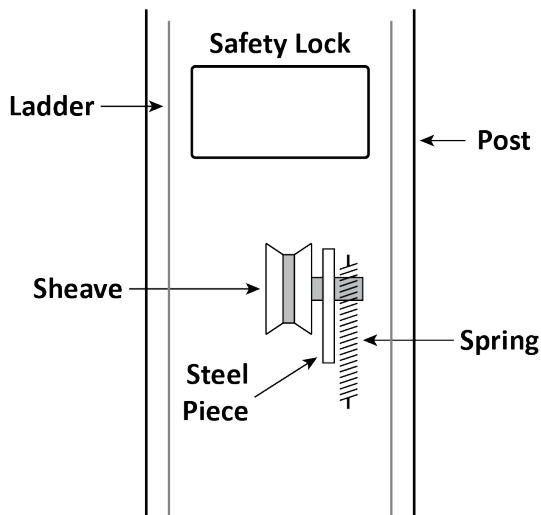

3. Once both Crosstubes are in position, **all Primary Safeties are engaged**, and the Slack Safeties have been disengaged, you can continue with the installation.

Secure the Safety Ladders

Because it is much easier to secure the Ladders at the bottom of each Post **after** the Crosstubes have been raised, that procedure is described here.

Note: The following procedure assumes that the Ladders are in place and secured at the top. If this is not the case, return to [Installing the Ladders](#).

To secure the Ladders:

1. Locate a Bolt, Washer, Spacer, second Washer, and Nut.

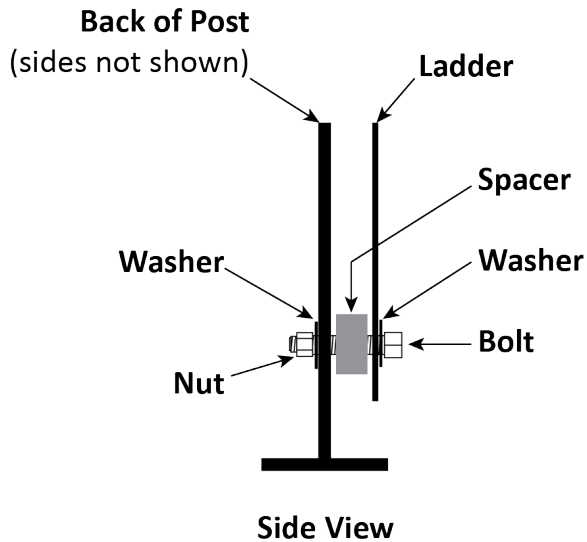

2. Put a Washer next to the Bolt head, then insert the Bolt just through the elongated hole near the bottom of the Ladder.
3. Put the Spacer into position between the Ladder and the back of the Post.
4. Push the Bolt through the Spacer and then through the back of the Post.
5. Take the second Washer and the Nut and install them on the end of the Bolt; secure the Nut.
6. Perform the same procedure to secure the other three Ladders on the Lift.

Note: Do not securely tighten the Top Nut at the top of the Top Cap at this point. The Top Nut and the Stop Nut will be used later to make sure the Lift is level. They can be securely tightened after you do the final leveling of the Lift; refer to **Final Leveling** for additional information.

⚠ WARNING Make sure that all four Ladders are correctly installed and secured. If not, the Lift may not be able to hold a vehicle, which is a danger to anyone under the vehicle or around it.

Install the Runways

Your Lift has two Runways:

- **Powerside Runway:** Has the Lift's Hydraulic Cylinder underneath it. Gets bolted into position. Has a hole on the outside (near the Rear of the Lift) that lets you route the Hydraulic Hose, Air Lines, and Return Line to the Power Unit. Cable routing starts under the Powerside Runway.
- **Offside Runway:** Is not bolted into position, so you can adjust the width between Runways; the Stop Blocks prevent it from moving too far to either side. The Offside Runway does not have a Hydraulic Cylinder under it, nor are there any Cables under it.

Orient the two Runways this way:

- Turn Plates at the Front of the Lift (the end opposite end from the Power Post and Ramps)
- Utility Rails on the inside

In this configuration, the Powerside Runway will be on the left and the Offside will be on the right, which is the orientation you want.

You can double check this by:

- Looking under the Runways. Only the Powerside Runway has a Hydraulic Cylinder underneath.
- Finding the ~1.5-inch wide hole in the side of the Powerside Runway at the Power Post. There is only one hole, it is only on the outside of the Powerside Runway, and it is next to the Power Post.

The following drawing shows the correct orientation of the Runways.

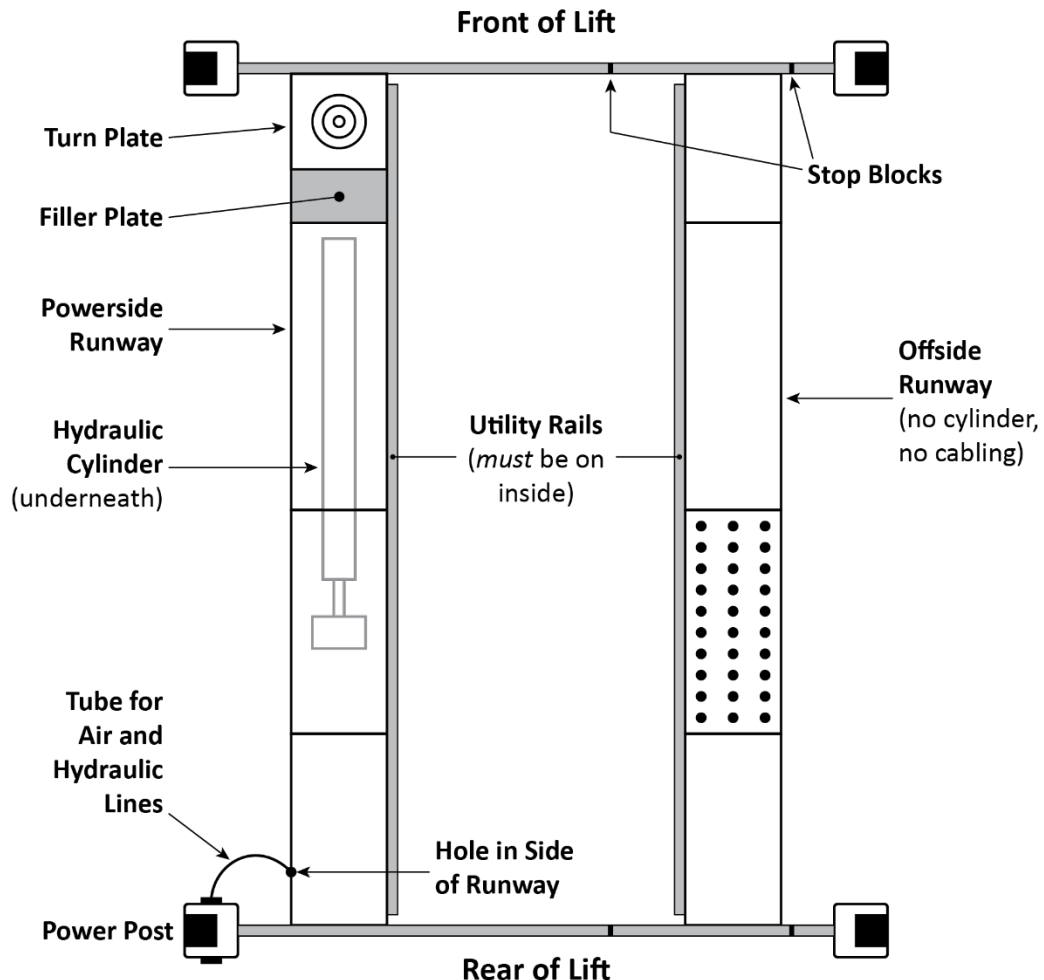

Use a Forklift or Shop Crane to raise the Runways and move them into position.

 **WARNING** Pay close attention when moving the Runways into position; they are long, very heavy, and could shift position or fall, potentially causing serious injury.

To install the Runways:

1. Correctly orient the Powerside Runway and the Offside Runway.

See the previous page for more information.

2. On the Powerside Runway, remove the Cable Sheaves.

To remove the Cable Sheaves: unscrew the Sheave Pin Lock Screw (on the underside of the Sheaves), pull out the Sheave Pin, then remove the Cable Sheaves.

There are four Cable Sheaves at the Rear of the Lift (near the Power Post) and two Cable Sheaves at the Front of the Lift. You need to remove all six.

Note: Keep all of the components nearby, you will be putting them back in shortly.

3. When the Cable Sheaves have been removed, use a Forklift or Shop Crane to pick up the Powerside Runway and move it into place on the Powerside of the Lift.

Make sure the Utility Rail is on the inside.

4. Bolt the Powerside Runway into place, two Bolts on each end going into the Crosstubes.

Use four M12 by 1.75 by 90 Hex Head Bolts.

5. Using a Forklift or Shop Crane, pick up the Offside Runway and move it into place between the Stop Blocks.

Make sure the Utility Rail is on the inside.

The Offside Runway does not have any Cable Sheaves, nor does it bolt into place.

6. Check all of the Safety Locks to make sure they are engaged.

You do not want anyone going under the Runways unless the Safety Locks are engaged.

 **WARNING** Do not continue with the installation until you have visually confirmed that all four Safety Locks are engaged. If they are not engaged, the Runways could move or fall, possibly causing personal injury or product damage.

 **WARNING:** Never walk or work under the Lift until all four Safety Locks are securely engaged.

 **DANGER** **Crushing hazard and pinch points.** Do not place any part of your body between the Runway and any moving part of the Lift unless visual confirmation is made that the safety lock is fully engaged, and that the Lift's downward motion is blocked by a Jack Stand, Forklift or other Load-Holding device that will prevent the Lift's downward movement while working under it.

Install the Flex Tube

The Flex Tube is a flexible, black tube that attaches to a hole on the Powerside Runway on one end and to the bottom of the Flex Tube Bracket Plate (near the Power Unit) on the other end.

A much longer Flex Tube is supplied and will need to cut to length. **Cut the Flex Tube to approximately 52 in. (1,320 mm) long.** The flexible tubing is about 1.5 in. (38 mm) in diameter. The connectors on each end are about 1.75 in. (44.5 mm) wide. Both ends are identical, it does not matter which end attaches to the Lift.

The Flex Tube consolidates and protects three different lines that exit from under the Powerside Runway on their way to the Power Unit.

- **Return Line.** A thin, black tube that returns extra Hydraulic Fluid to the fluid reservoir on the Power Unit.
- **Air Line.** A thin, black tube, the Air Line provides air pressure that is used to disengage the Safety Locks so that the Runways may be lowered.
- **Hydraulic Hose.** A heavy, black hose that routes Hydraulic Fluid from the Power Unit to the Hydraulic Cylinder.

Installation of the Flex Tube is usually done in two parts: the first is completed after the Powerside Runway is installed (now), the second part after the Power Unit (and the Flex Tube Bracket Plate) is installed (later in the installation).

The following drawing shows the Flex Tube.

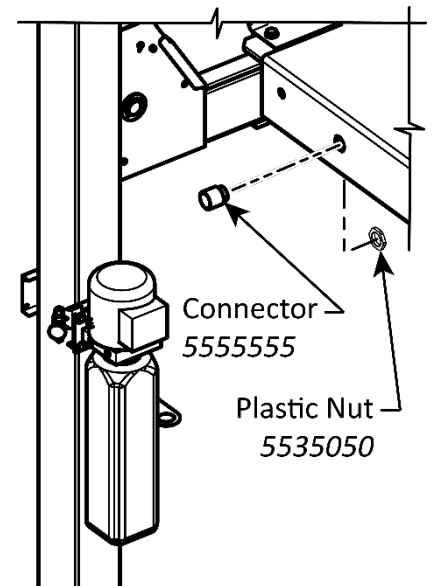
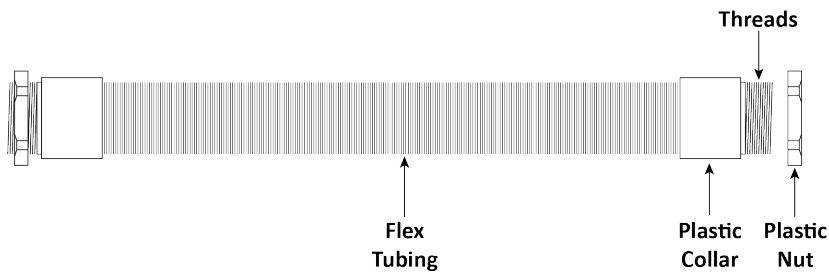

To install the Flex Tube on the Powerside Runway:

1. Unscrew the Plastic Nut from one end of the Flex Tube.
2. Holding the Flex Tube by the Plastic Collar, put the Threads on the end of the Flex Tube through the hole on the Powerside Runway.
3. On the inside of the Powerside Runway, screw the Plastic Nut back onto the Threads of the Flex Tube and tighten it.
4. Let the other end of the Flex Tube hang in place until the Flex Tube Bracket Plate is installed.

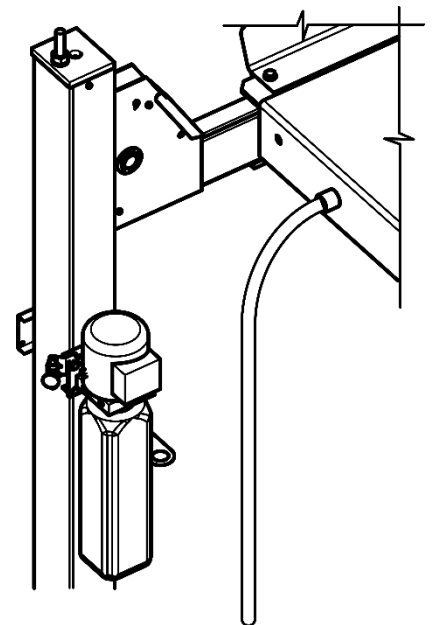

Working with Compression Fittings and Tubing

Your Lift comes with a roll of ¼ inch, black, polyethylene Tubing (also called Poly-Flo® Tubing) that is used with Compression Fittings in two ways: for the Return Line and for the Air Lines.

Important: While both lines use Tubing and Compression Fittings, the Return Line and Air Lines are used for completely separate purposes; do not connect the two together.

Note: Compression Fittings are different from Hydraulic Fittings. This section covers Compression Fittings only.

The components involved with Compression Fittings include:

- **¼ inch, black, polyethylene Tubing.** You use a single piece of Tubing for the Return Line. The Air Lines require multiple Tubing pieces. Create the Tubing pieces for both the Return Line and the Air Lines by cutting lengths from the long roll of Tubing supplied with your Lift.
- **Elbow Compression Fittings.** The Return Line uses two Elbow Compression Fittings, one at each end.
- **Tee Compression Fittings.** The Air Lines require three Tee Compression Fittings.
- **Nuts, Ferrules, Rods, and Threads.** Each connector on Elbow and Tee Compression Fittings have a Nut, Ferrule, Rod, and Threads (see drawing below). The Nut holds the Tubing and Fitting together. The Ferrule compresses when you tighten the Nut on the Threads to make a secure connection. The Rod goes inside the Tubing so that nothing leaks out.

The following drawing shows the components of a connector on a Tee Compression Fitting.



Important: *Ferrules can only be tightened once.* When you tighten the Nut on the Threads, the Ferrule gets compressed; it literally changes shape and **cannot** be used again.

To connect Tubing to a Compression Fitting:

1. Push the Tubing through the Nut and over the Rod.

Do not push hard; you only need the Tubing to go a little way over the Rod. You cannot see the Ferrule at this point, but the Tubing must go through the Ferrule and over the Rod.

2. Slide the Nut on the Tubing **away from the Fitting**; if the Nut is still on the Threads, unscrew it from the Threads and then slide it away from the Fitting. See the drawing above.
3. Slide the Ferrule over the Tubing, away from the Fitting and towards the Nut.
4. With the Nut and the Ferrule out of the way, push the Tubing further over the Rod until it stops.
5. Slide the Ferrule and the Nut back to the Threads on the Fitting.

The Ferrule goes around the Rod and under the Threads. The Nut goes onto the Threads.

6. Tighten the Nut.

Remember that the Ferrule can only be used once; do not tighten the Nut until everything is ready.

Install the Return Line

The Return Line takes excess Hydraulic Fluid coming out of the Hydraulic Cylinder and sends it back into the Fluid Reservoir on the Power Unit.

The Return Line is a single piece of ¼ inch, black, polyethylene Tubing with Elbow Compression Fittings on each end. You need to cut off a piece of the supplied Tubing — of the right length, 18 to 20 feet — to create the Return Line.

Important: The Return Line uses the same ¼ inch, black, polyethylene Tubing as the Air Lines. Be sure not to confuse the two; the Return Line and the Air Lines do completely different things and must be kept separate from each other.

The following drawing shows where the Return Line connects on the Lift.

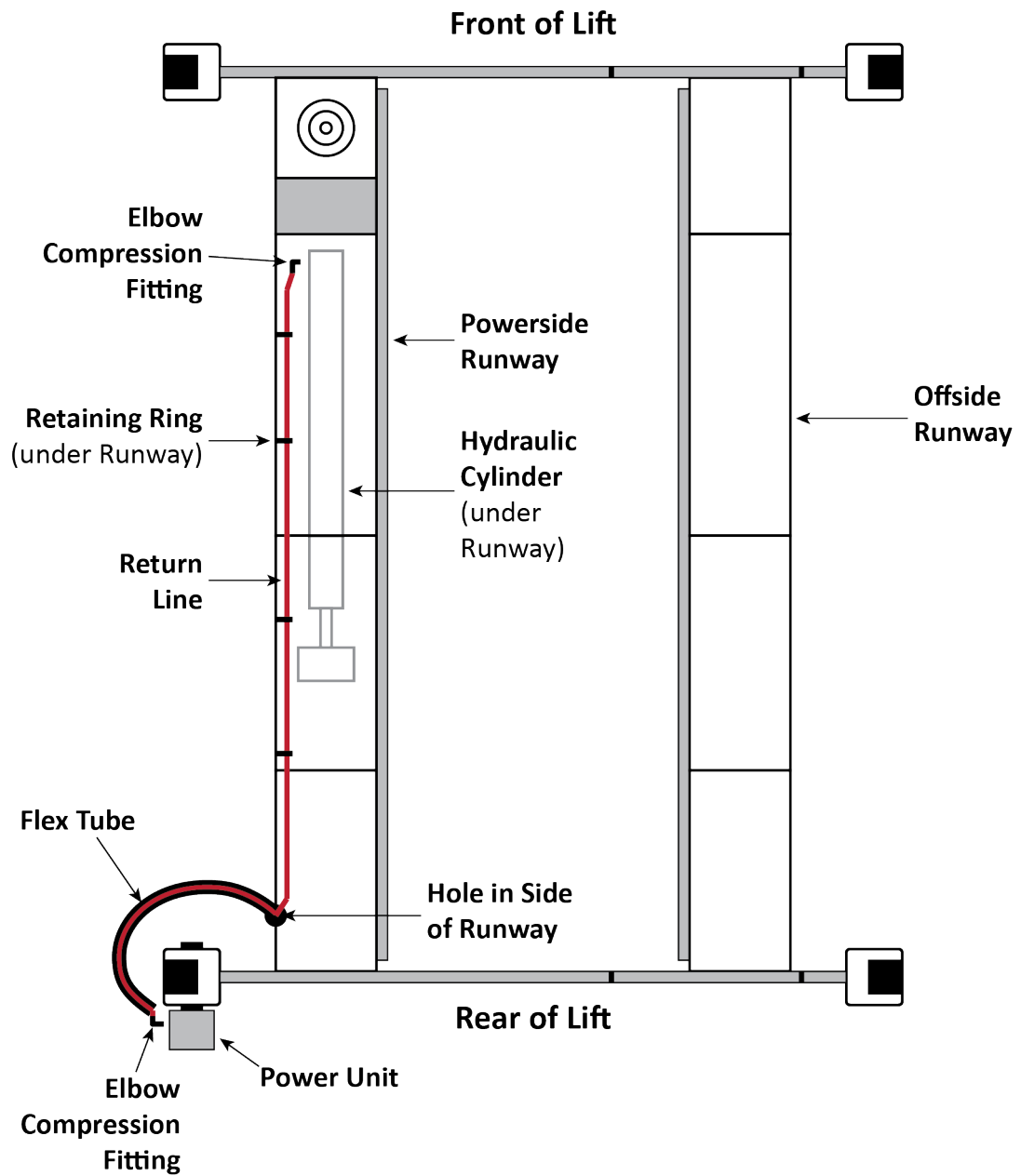

The following drawing shows the Return Line.

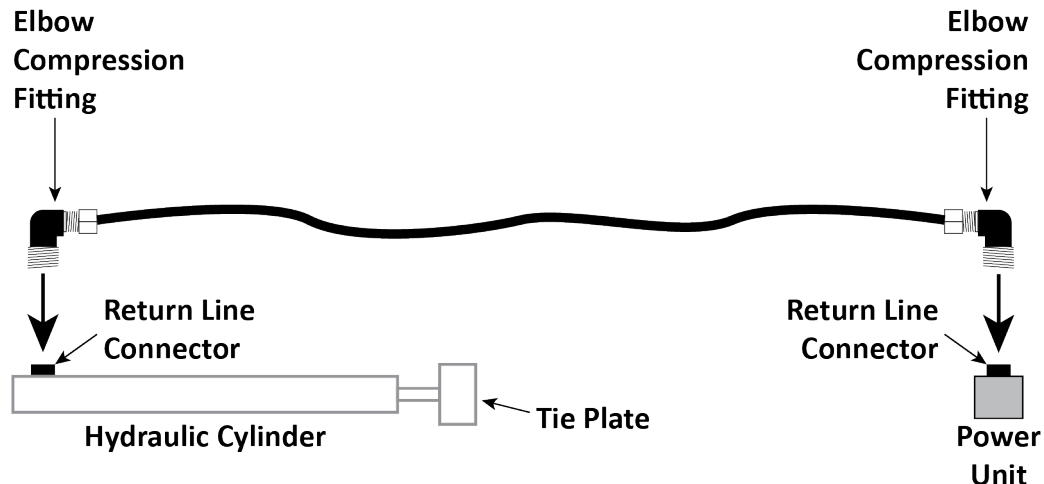

Drawing not to scale. Some components not shown. Some components exaggerated.

To install the Return Line:

1. Attach an air pressure source to the Return Line Connector on the Hydraulic Cylinder and extend the Cylinder's Piston and Weldment Plate until it is fully extended towards the Power Post.

This step does not apply to installing the Return Line, but it does need to be done at this point in the Lift installation.

Do not exceed 50 psi. If the Cylinder does not move, stop using air pressure; instead, use a pulling device (such as a Come Along Tool) to extend the Piston and Weldment Plate. Be careful not to damage the Piston or the Weldment Plate.

2. Measure the distance from the Return Line connector on the Hydraulic Cylinder to the Return Line connector on the Power Unit.
3. Cut a piece of Tubing to the measured length from the roll of Tubing that comes with the Lift.
It is better to cut the Tubing a little too long rather than a little too short.
4. Route the Tubing from the Hydraulic Cylinder, through the Retaining Rings on the underside of the Powerside Runway, through the Flex Tube, and out next to where the Power Unit will be installed (see the drawing on the previous page).

You need to route the Return Line through the Retaining Rings so that it is out of the way of where the Cables will be routed.

5. Remove the Shipping Plug from the Return Line Connector on the Hydraulic Cylinder.
6. Connect and tighten the threaded end of an Elbow Compression Fitting into the opening where the Shipping Plug used to be.
7. Connect one end of the Return Line to the Elbow Compression Fitting you just installed.
Refer to **Working with Compression Fittings and Tubing** for instructions.
8. Leave the Power Unit end of the Return Line hanging out of the Flex Tube for now.

It will be connected to an Elbow Compression Fitting and to the Power Unit later in the installation.

Install the Air Lines

The Air Lines use air pressure to disengage the Safety Locks in each Post so that you can lower the Runways. **It is the owner's responsibility to supply the air pressure (minimum of 50 psi at 3 CFM required).**

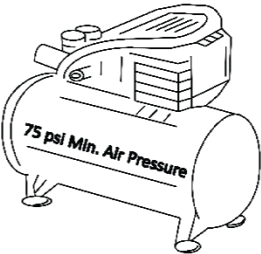
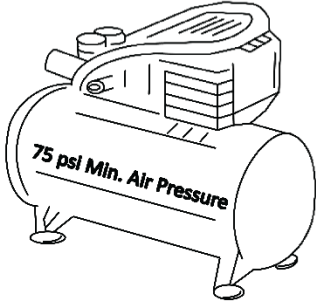
Suggested Air Compressors for use with Four-Post Lifts				
Model Level	Service Size	Air Tank Volume	CFM	Minimum Operational PSI
Good		3 Gallon Min.	3 to 25	50
Better		10 Gallon Min.	3 to 25	50
Best		20 Gallon Min.	3 to 25	50

You will need more of the ¼ inch, black, polyethylene Tubing delivered with the Lift and three Air Line Tee Connectors to install the Air Lines.

Important: Do not confuse the Air Lines with the Return Line. They use the same Tubing and similar connectors, but they are used for completely different things; the two systems cannot be connected to each other.

The Air Line Elbow Connectors on the Crosstube Gussets are pre-installed at the factory.

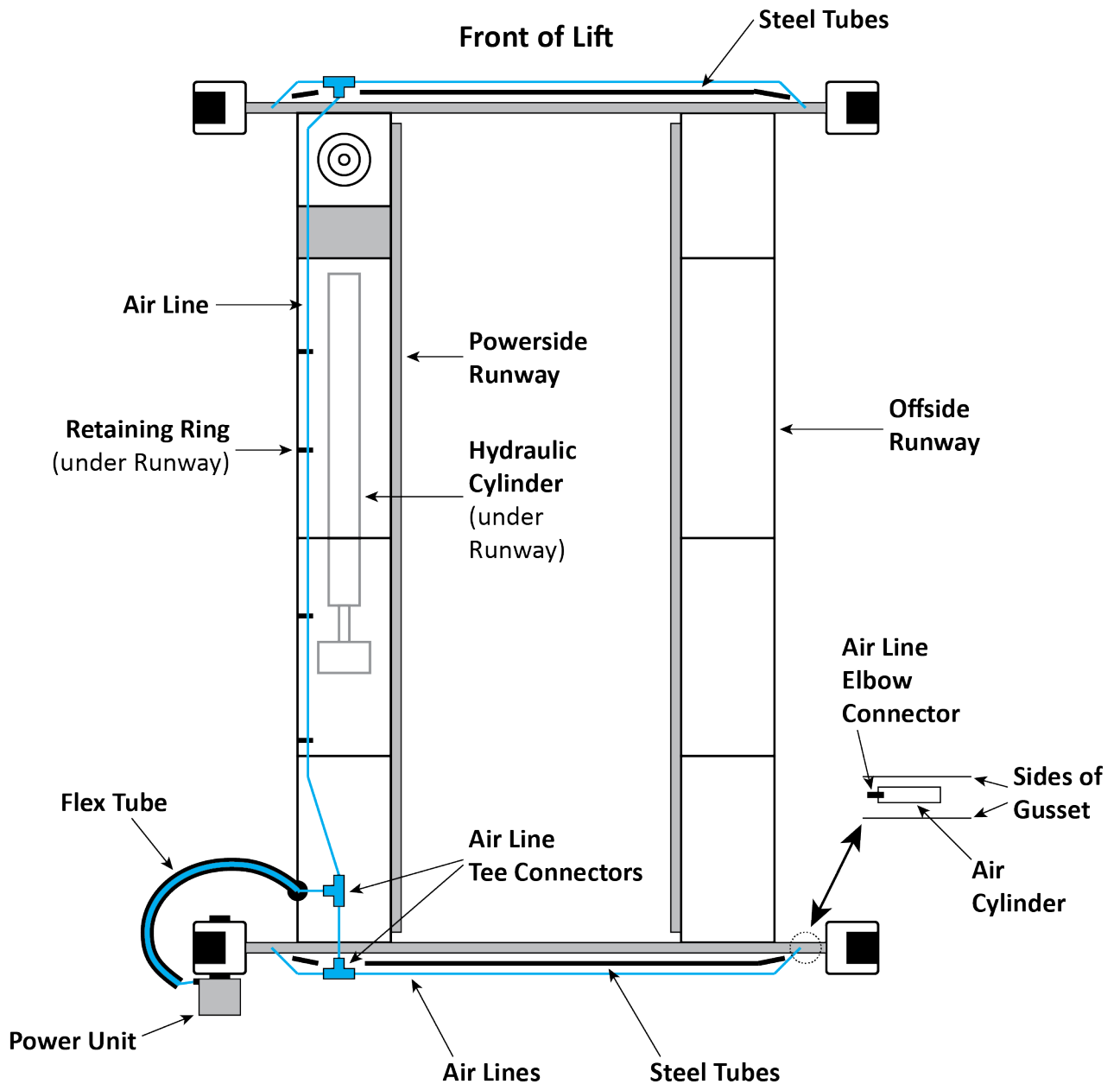

Drawing not to scale. Some components not shown. Air Lines shown outside Steel Tubes for clarity.

To install the Air Lines:

1. Find the roll of supplied ¼ inch, black, polyethylene Tubing and three Air Line Tee Connectors.
2. Measure the distances for each of the seven Tubing pieces you will need (see the sketch on the previous page) for the Air Lines.
3. Cut seven pieces of Tubing to the measured lengths from the roll of Tubing.
4. Connect the various pieces of Tubing to the Air Line Tee Connectors on the Lift, as shown on the previous page for the locations of the Tubing pieces.

Make sure to position the three Air Line Tee Connectors as shown in the drawing.

Also make sure to route the long Tubing piece under the Powerside Runway through the Retaining Rings. Verify the Air Lines will not become tangled with the Lift Cables.

⚠ WARNING Make sure to route the Tubing pieces on the **outside** ends of the Front and Rear Crosstubes through the Steel Tubes welded to the Crosstubes. This keeps the Tubing and the Tee Connectors from being damaged as you use the Lift. This is critical. If the Air Lines are damaged, the Safety Locks on the Lift may not function correctly. If you notice that Tubing has become disconnected or damaged, take the Lift out of service and repair the Air Lines.

Refer to **Working with Compression Fittings and Tubing** for more information about connecting the Tubing to the Air Line Tee Connectors.

5. Leave the Power Unit end of the Air Line hanging out of the Flex Tube for now.
It will be connected to the Pushbutton Air Valve later in the installation process.

About Thread Sealants

Liquid Thread Sealant lubricates and fills the gaps between the Fitting threads and leaves no residue that could contaminate the Hydraulic Fluid.

Other types of Thread Sealants (like Teflon Tape) can shred during installation or removal and eventually enter the Hydraulic System.

Thread Sealant can be used with most Hydraulic Fittings, although you probably only need to use with NPT connectors.

Apply the thread sealant when the ambient temperature is between +46.5°F to +70°F (+8°C to 21°C)



To apply Thread Sealant:

1. Verify the fittings and connectors are clean and dry.

If you are adding Thread Sealant to a Fitting or connector that has already been used with a different sealant, use a wire brush to thoroughly remove the old sealant before adding more.

2. Skipping the first thread, apply a small amount of Thread Sealant to the next four threads of the Fitting.

⚠ WARNING Always wear the proper protective equipment when handling Thread Sealant.

You only need a small amount. The sealant spreads to the other threads as it is tightened into place. Excess Sealant will be pushed out when the Fitting is tightened; use a rag to wipe away the excess.

3. Tighten the Fitting into the connector; do **not** over tighten the Fitting.
4. Allow the **24-hour** manufacturer-recommended curing time before pressurizing the system.

Identifying Hydraulic Fittings

Joint Industry Council (JIC)

National Pipe Thread (NPT)

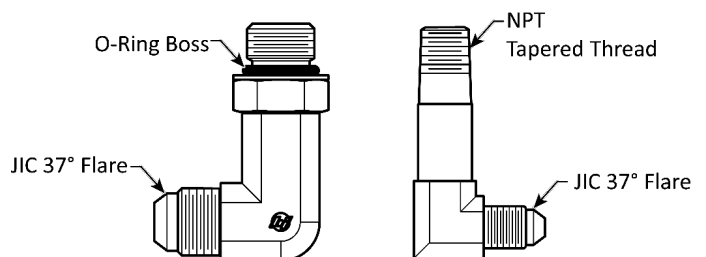

Install the Hydraulic Hose

The Hydraulic Hose moves Hydraulic Fluid from the Power Unit to the Hydraulic Cylinder, which pulls the Lift Cables to raise the Runways.

To install the Hydraulic Hose, you will need:

- **The Hydraulic Hose.** The Straight end attaches at the Power Unit and the end with the 90° attaches to the Power Unit.
- **One JIC to NPT Hydraulic Elbow Fitting.** The JIC end attaches to the Curved end of the Hydraulic Hose and the NPT end to the Hydraulic Cylinder.
- **One JIC to ORB Hydraulic Fitting.** The JIC end attaches to the Straight end of the Hydraulic Hose and the ORB end to the Power Unit.

The figure below displays the Hydraulic Hose routing on the Lift.

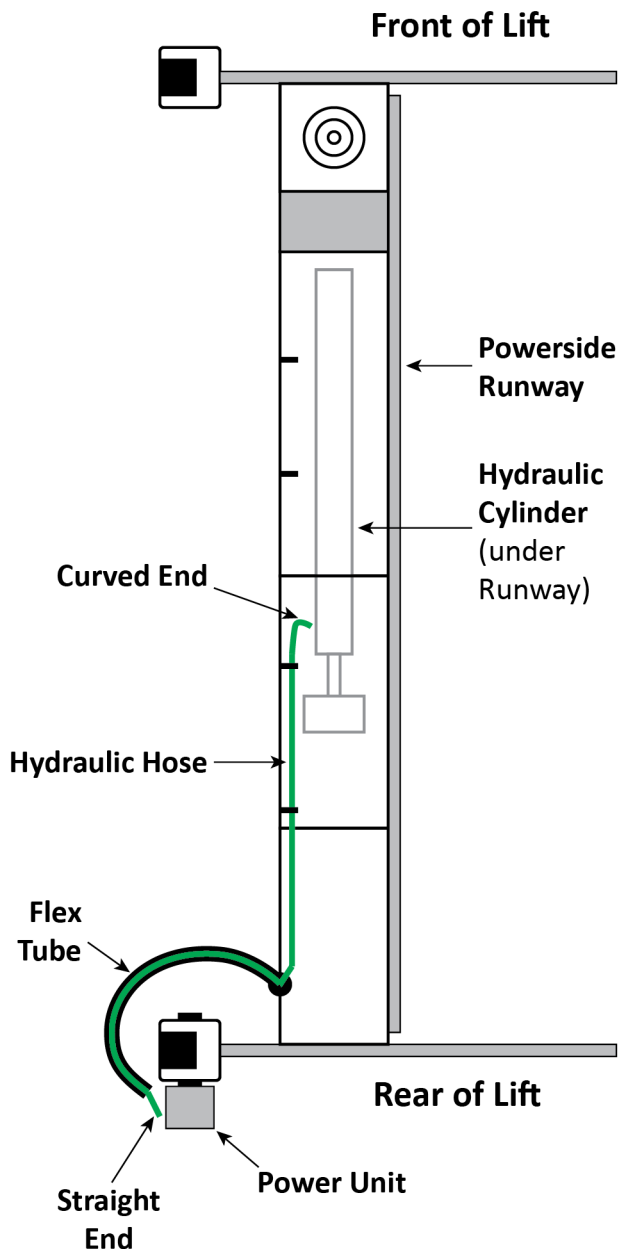

Notes: Offside Runway not shown.

The Hydraulic Hose can connect to the Power Unit at either Hydraulic Power Out connector, P1 or P2.

Figure not to scale. Not all components shown.

The figure to the right displays the Hydraulic Hose and its connectors in more detail.

To install the Hydraulic Hose:

1. Retrieve the Hydraulic Hose and two Hydraulic Fittings.
2. Route the straight end of the Hydraulic Hose beginning at the Hydraulic Cylinder, route the Straight end through the Retainers and then through the Flex Tube to exit near the Power Unit.
3. On the Hydraulic Cylinder, remove the Shipping Plug from the Cylinder Port at the Piston Rod end.
4. Apply thread sealant to the NPT end of the -04JIC x 3/8 NPT elbow.
5. Thread the NPT end of the Elbow into the on the Hydraulic Cylinder where you just removed the Shipping Plug.
Tighten until secure.
Leave the JIC connector pointing up; this will help keep the Hydraulic Hose up and away from where the Cables will be installed.
6. Attach the Curved end of the Hydraulic Hose to the JIC connector that is facing up.
Tighten until secure.
7. Leave the Straight end of the Hydraulic Hose coming out of the Flex Tube; do not connect it to the Power Unit at this point.

Note: The ORB connector of the JIC-to-ORB Fitting will be connected to the Power Unit later in the installation.

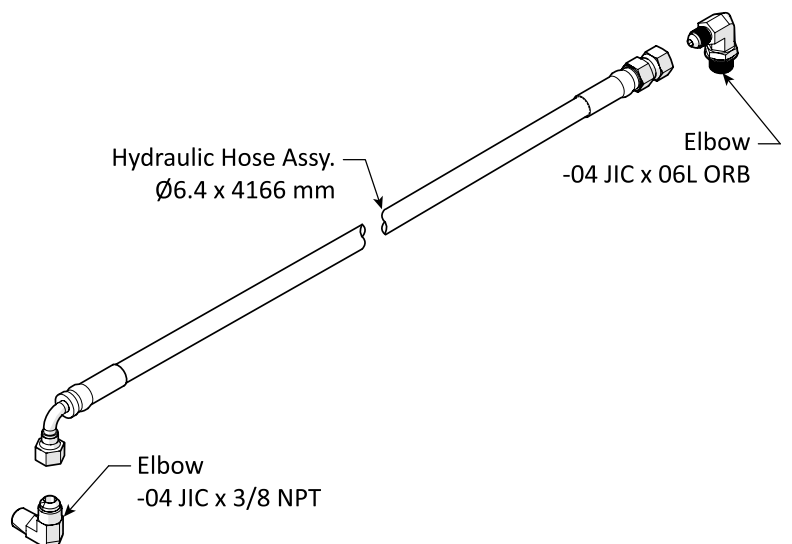
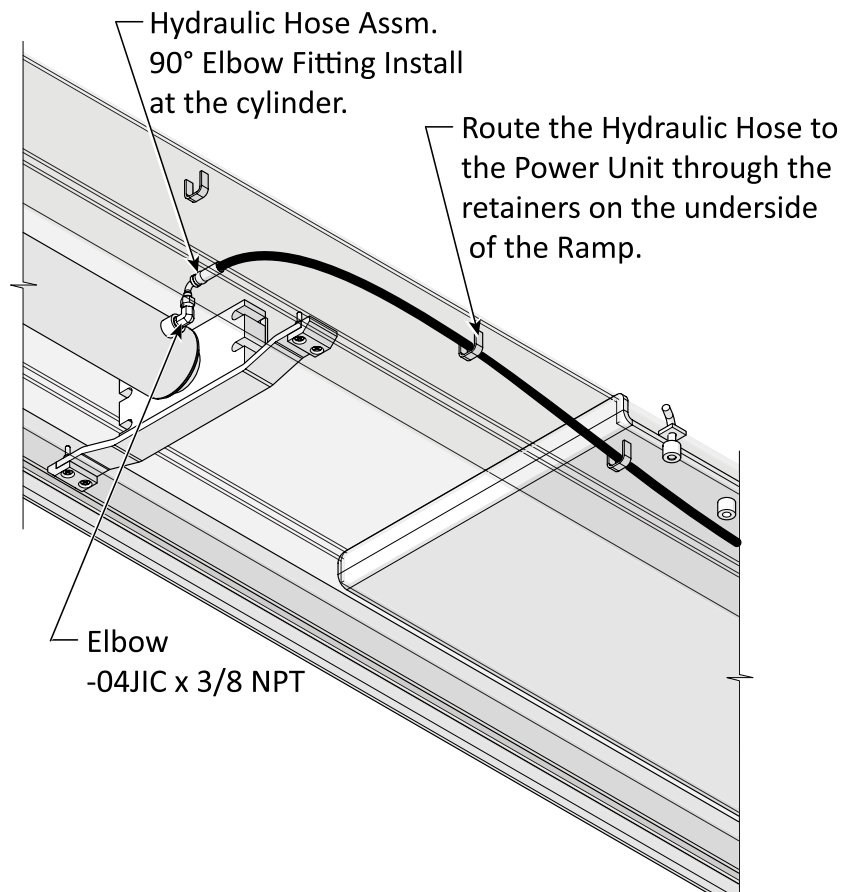

Route the Lift Cables

Before routing the Cables on your Lift, you need to know the following:

- BendPak strongly recommends using gloves when working with the Cables.
- Each Lift has four Cables. All four are different lengths; they can only be used in one position. If you use them in the wrong position, they will be too short or too long.
- All four Cables have a Button end and a Threaded end. The Threaded end has a label on it that identifies the Lift Model the Cable is designed for (and **must** be used with), the part number (if you need to replace it), and its length (in millimeters).

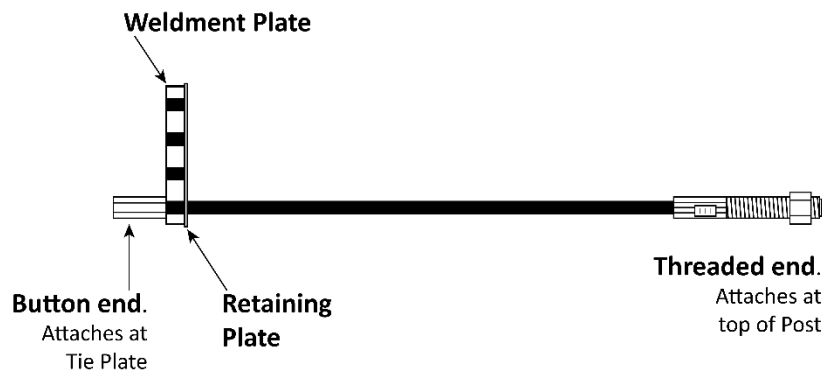

Figure not to scale. Not all components shown. The Weldment Plate, located under the Powerside Runway, is attached to the end of the Piston on the Hydraulic Cylinder.

- The Button end of each Cable connects at the Weldment Plate on the underside of the Powerside Runway. The Button ends of each Cable stay on one side of the Weldment Plate (as shown above), while the rest of the Cable goes through the Weldment Plate and the Retaining Plate on its way toward the appropriate Sheaves and then to the Post to which it attaches.
- The Threaded end of each Cable goes around the appropriate Sheaves and then is routed to a Post, where it is attached at the top. Before routing each Cable, remove the Nut at the Threaded end; you cannot route the Cable around the Sheaves if the Nut is still in place.
- The weldment plate includes a Retaining Plate on one side. The Retaining Plate holds the Button ends of the Cables in place after all four Cables are installed. Do not take the Retaining Plate off to install the Cables; instead, loosen it so that you can slip the Button end of the Cable into the correct slot. When all four Cables are installed, tighten the nut to secure the Retaining Plate.
- There are two kinds of Sheaves: Cable Sheaves and Gusset Sheaves. There are four Cable Sheaves at the Rear of the Powerside Runway and two Cable Sheaves at the Front of the Powerside Runway, for a total of six Cable Sheaves for the Lift. There are four Gusset Sheaves, one per Crosstube Gusset.
- Cable Sheaves come installed in the Powerside Runway. However, they must be removed prior to putting the Runways in place. When you start routing the Cables, all the Cable Sheaves should have been removed.
- Gusset Sheaves come installed in the Cross Tubes and **must not** be removed.
- Cable Sheaves are put back into place as you route each Cable. All of the six Cable Sheaves (two at the Front of the Lift, four at the Rear) are identical; you can use them at any location.
- The two Cable Sheave **Pins** are identical.
- A Cable and its corresponding Cable Sheave (or Sheaves) are put into place one at a time, starting from the Weldment Plate to the top of the Post. Cables and their Cable Sheaves must be put into

place at the same time. Do not install the next Cable/Cable Sheave pair until the previous Cable/Cable Sheave pair are in place.

- Each Crosstube Gusset has a Cable Lock Pin just under the bottom of the Gusset Sheave. Each Cable Lock Pin needs to be removed when you are routing the Cable for the applicable Post. Reinstall the Cable Lock Pin once the Cable is in place.

The Cable Lock Pin prevents the Cable from coming out later; there is not enough space between the bottom of the Gusset Sheave and the Cable Lock Pin for the Cable to slip out.

- In the figures on the following pages, the Cables and Cable Sheaves are labelled A, B, C, and D. These letters indicate the order in which they are put into place. Cable A and Cable Sheave A are put into place first, then Cable B and Cable Sheave B, and so on. These letters are **not** on the label on the Threaded end. You must match the Cable letter with the length information.

The Cable Sheave letters apply to the four Cable Sheaves at the Rear of the Lift. There are also two Cable Sheaves at the Front of the Lift; they are associated with Cables C and D.

- The order in which the Cables and Sheaves are put into place is based on the order the Cable Sheaves must be placed, **not the length of the Cables.**
- The four Cables for the **HDS-14LSX** are:
 - **A: 161.5 in.** (4,100 mm) (part number 5595065)
 - **B: 225.75 in.** (5,732 mm) (part number 5595066)
 - **C: 432.75 in.** (10,990 mm) (part number 5595075)
 - **D: 367.75 in.** (9,339 mm) (part number 5595074)
- The four Cables for the **HDS-14LSXE** are:
 - **A: 161.5 in.** (4,100 mm) (part number 5595065)
 - **B: 225.75 in.** (5,732 mm) (part number 5595066)
 - **C: 462.75 in.** (11,751 mm) (part number 5595068)
 - **D: 396.75 in.** (10,076 mm) (part number 5595067)

Important: Make sure to use the correct Cable for each route. If a Cable is installed in the wrong route, it will be too short or too long. Remember that the length of each Cable is printed on a label on the Threaded end.

- All four Cables start at the Weldment Plate attached to the Cylinder and then route around a Cable Sheave at the **Rear** of the Lift. Cables A and B then go to the Gusset Sheave at the bottoms of the Posts to which they attach.

Cables C and D start at the Weldment Plate, go around a Cable Sheave at the Rear of the Lift, and then are routed to the Front of the Lift where they go around another Cable Sheave, and then around the Gusset Sheave at the bottoms of the Posts to which they attach.

In summary: Cables A and B go through one Cable Sheave and one Gusset Sheave. Cables C and D go through two Cable Sheaves and one Gusset Sheave.

See the figures on the following pages for routing information.

The figure below details the Cable routing.

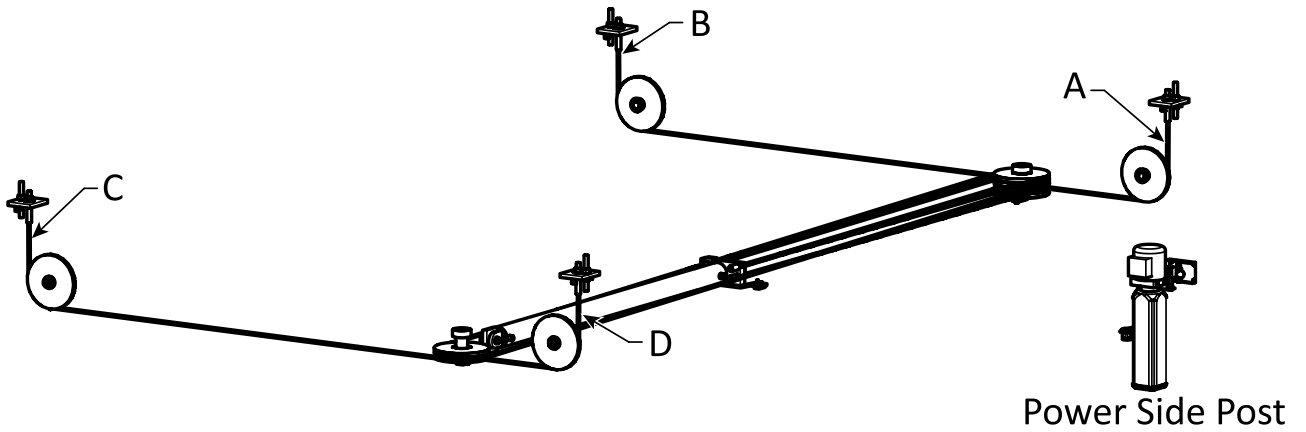

Not to scale. Components removed for clarity.

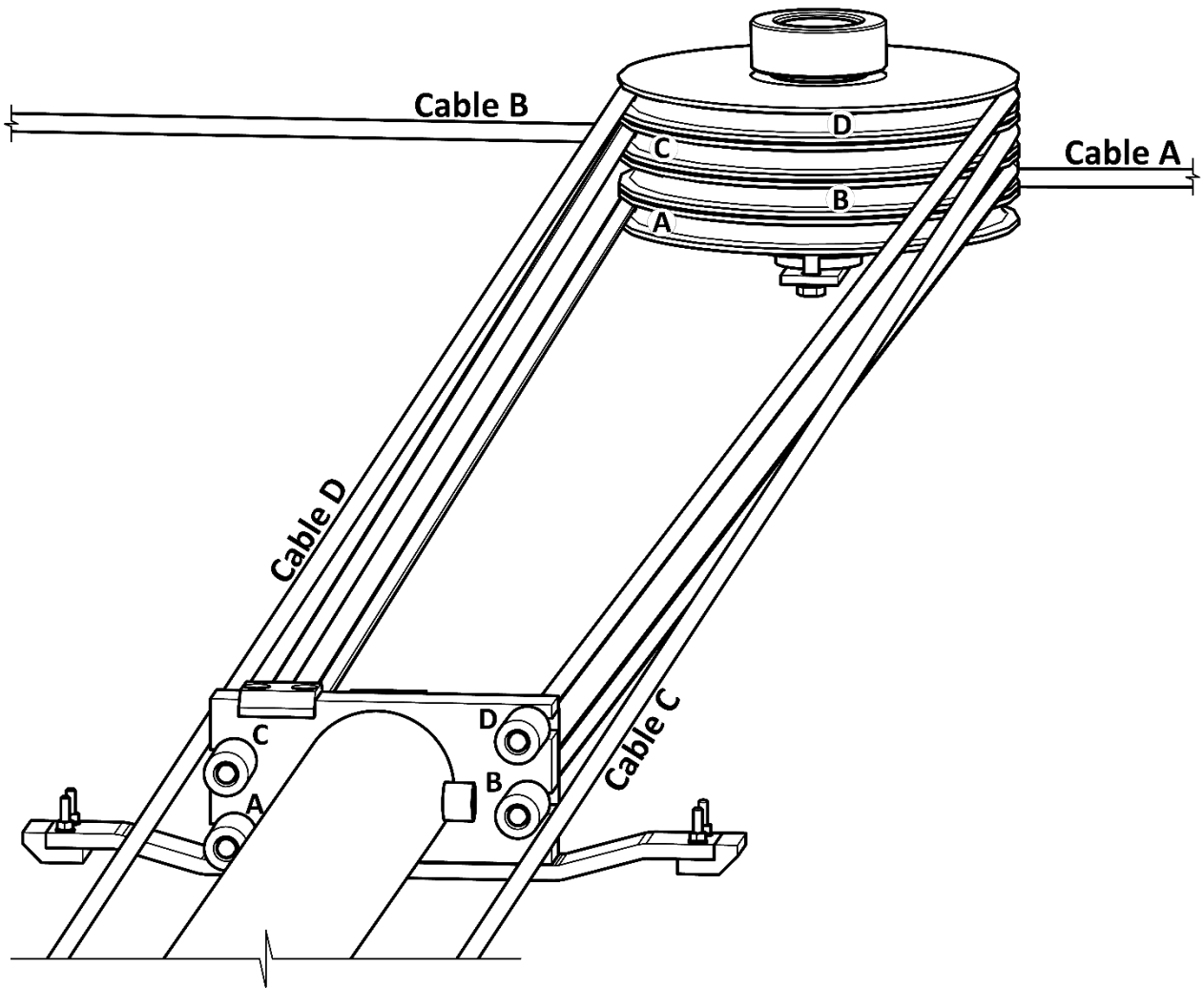

Not to scale. Components removed for clarity.

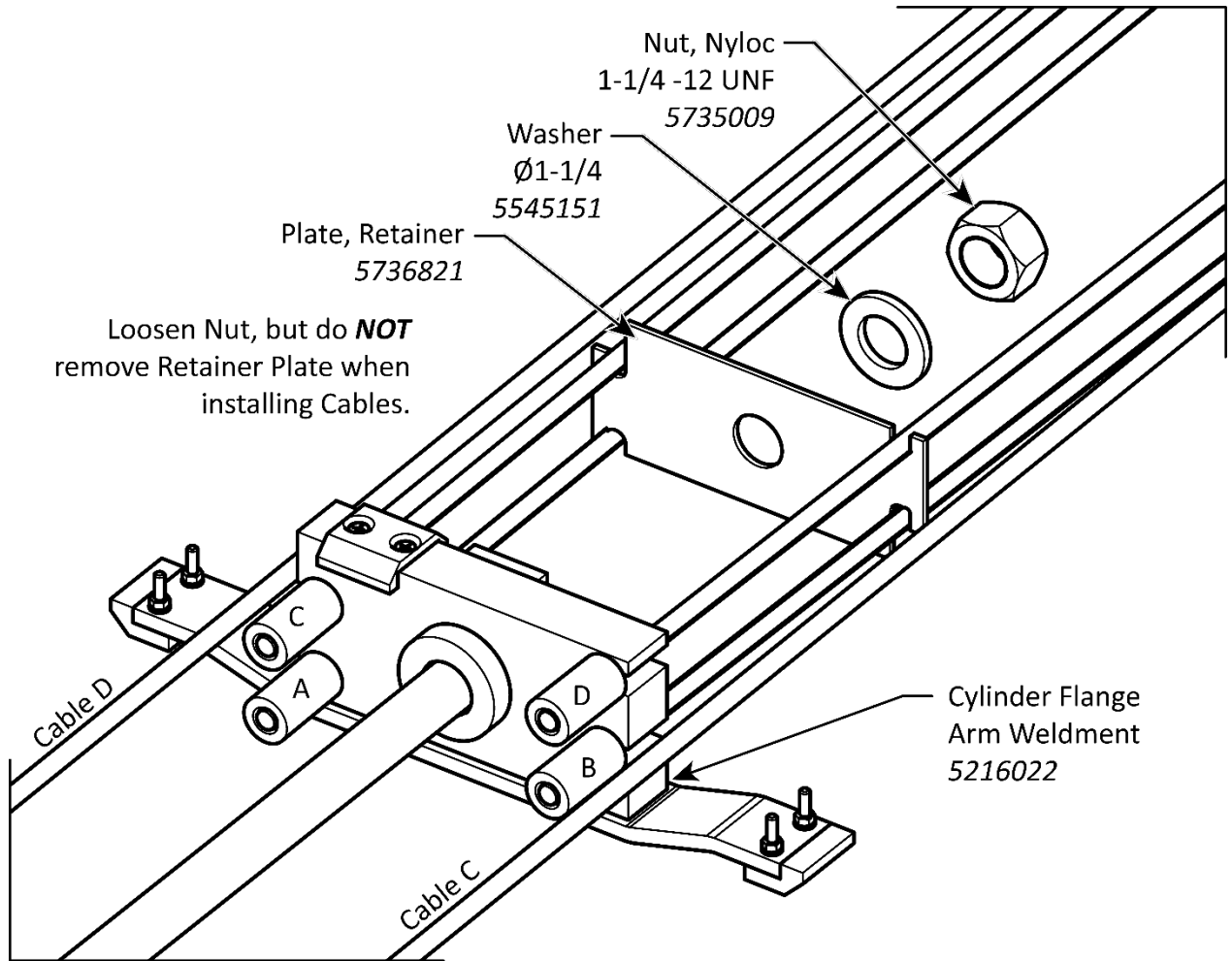

Not to scale. Components removed for clarity.

Before routing your Cables, Verify the Piston of the Hydraulic Cylinder has been extended, which is part of the procedure described in **Installing the Return Line**.

If the Piston has **not** been extended, extend it prior to routing the Cables: remove the Elbow Compression Fitting from the Return Line Connector, extend the Piston using air pressure or a pulling device, then reinstall the Elbow Compression Fitting.

Note: There are separate procedures for routing each Cable.

To route Cable A to the Power Post:

1. Find the four Cables for your Lift model.
Check the labels on each Cable to verify you have the correct cable.
2. Retrieve the six Cable Sheaves that were removed earlier.
The Gusset Sheaves are installed and should not be removed.
The six Cable Sheaves and pins are identical.
3. Loosen the Retaining Plate enough so that you can slip the Button end of each Cable into its spot on the Weldment.

Do not remove the Retaining Plate just loosen the Nut enough to provide room to slip the Button End of each Cable into place.

- Find Cable A, unscrew the Nut from the Threaded end (the Nut cannot be on during routing, but keep it nearby), slip the Button End past the Retaining Plate and into its slot on the Weldment Plate, then route the Threaded End of the Cable towards its Cable Sheave at the Rear of the Lift.

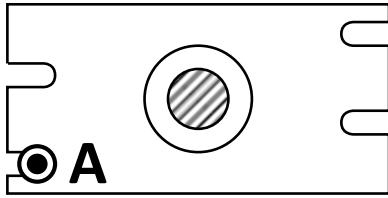
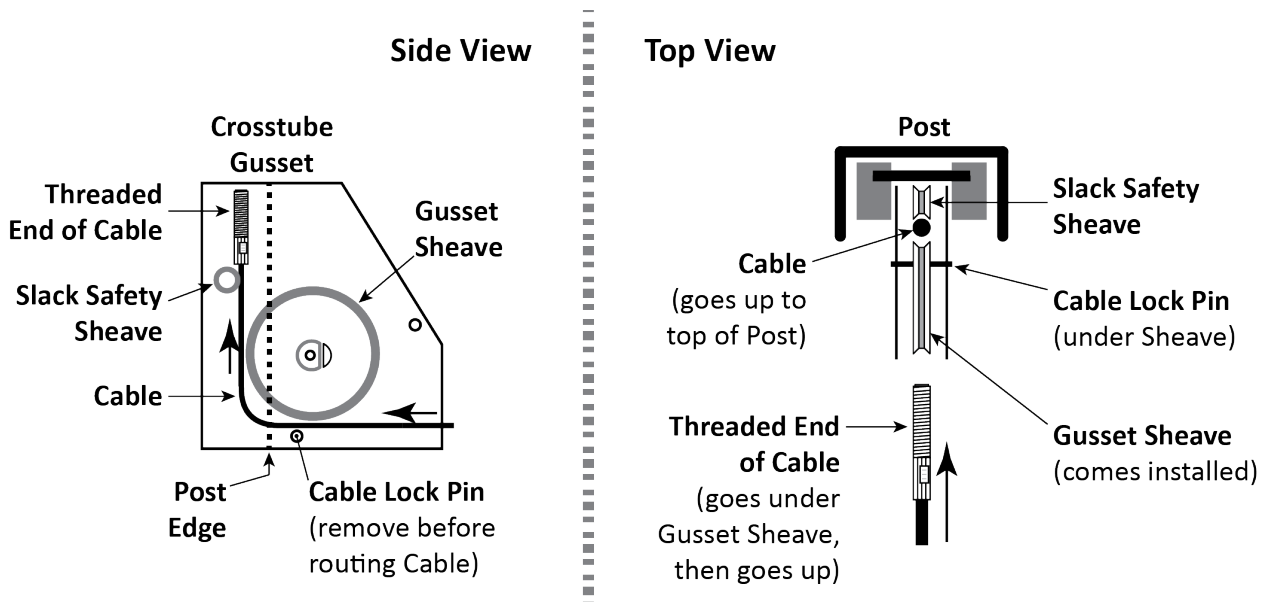

Figure displays Button End of Cable A in its slot on the Weldment Plate.

View is from Front of Lift looking back towards the Power Post. Not to scale. Not all components shown.

- Route the Cable into the Window on the Crosstube, push it toward the Power Post, then pull the Threaded end out of the Crosstube at the bottom of the Gusset. Let the Threaded end hang out of the Crosstube for now.
- Put Rear Sheave A in place, at the bottom of what will be the stack of four Sheaves when all four Cables are in place, then make sure Cable A is seated in Rear Sheave A.
- Remove the Cable Lock Pin on the bottom of the Gusset on the Power Post. Keep it handy; you will be putting it back in place soon.
- Route the Threaded end of Cable A **under** the Gusset Sheave, then up towards the Top Cap at the top of the Post.

When you start routing the Cable up, it **must** be between the Gusset Sheave and the Slack Safety Sheave, as shown in the drawing below.



Drawing not to scale. Not all components shown. Includes side view and top view of same area.

Important: When routing a Cable in its Post, the Cable must go **under** the Gusset Sheave and then, when it heads up towards the top of the Post, it must be on the side of the Slack Safety Sheave, as shown above. When the Cables are pulled tight, the Cable prevents the Slack Safety from engaging, which is what you want. If the Cable is **not in this exact location**, the Slack Safeties will **not** work correctly.

9. Push the Threaded end of Cable A through the Top Cap and **hand tighten** it in place with the Nut you removed just before starting to route the Cable.

You only want to hand tighten the Nut at this point so that there is a little play in the cabling. We will securely tighten all four Nuts later in the installation procedure.

Note: The Threaded end of Cable A should go just a little bit through the Top Cap. If it is too long or way too short, you probably have the wrong Cable. If it is just a few inches short, then the Piston on the Hydraulic Cylinder may not have been pulled out far enough.

10. Reinstall the Cable Lock Pin near the bottom of the Crosstube Gusset.

Cable A is now correctly routed to its Post.

To route Cable B to the Rear Offside Post:

1. Find Cable B, unscrew the Nut from the Threaded end, slip the Button end past the Retaining Plate and into its slot on the Weldment Plate (note that Cable B mounts on the other side of the Weldment Plate), then route the Threaded end of the Cable towards the Rear of the Lift.

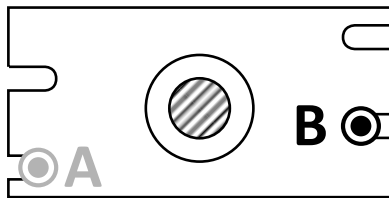

Figure displays Button End of Cable B in its slot on the Weldment Plate.

View is from Front of Lift looking back towards the Power Post. Not to scale. Not all components shown.

2. Route the Cable into the Window on the Crosstube, push it toward the Rear Offside Post, then pull the Threaded end out of the Crosstube at the bottom of the Gusset. Let the Threaded end hang out of the Crosstube for now.
3. Put Rear Sheave B in place, on top of Rear Sheave A, then make sure Cable B is seated in Rear Sheave B.
4. Remove the Cable Lock Pin on the bottom of the Gusset on the Rear Offside Post.
Keep it handy; you will be putting it back in place soon.
5. Route the Threaded end of Cable B **under** the Gusset Sheave, then up towards the Top Cap at the top of the Rear Offside Post.

When you start routing the Cable up, it **must** be between the Gusset Sheave and the Slack Safety Sheave.

Important: When routing a Cable in its Post, the Cable must go **under** the Gusset Sheave and then, when it heads up towards the top of the Post, it must be on the side of the Slack Safety Sheave. If the Cable is **not in this exact location**, the Slack Safeties will **not** work correctly.

6. Push the Threaded end of Cable B through the Top Cap and **hand tighten** it in place with the Nut you removed just before routing the Cable.

You only want to hand tighten the Nut at this point so that there is a little play in the cabling. We will securely tighten all four Nuts later in the installation procedure.

Note: The Threaded end of Cable B should go just a little bit through the Top Cap. If it is too long or way too short, you probably have the wrong Cable.

7. Reinstall the Cable Lock Pin near the bottom of the Crosstube Gusset.

Cable B is now correctly routed to the Rear Offside Post.

Important: The two Sheaves at the Front of the Lift are called Front Sheave C and Front Sheave D. There is no Front Sheave A or Front Sheave B. The C and D in the names of Front Sheave C and Front Sheave D refer to the Cables that go around them.

To route Cable C to the Front Offside Post:

1. Find Cable C, unscrew the Nut from the Threaded end, slip the Button end past the Retaining Plate and into its slot on the Weldment Plate, then route the Threaded end towards the Rear of the Lift.

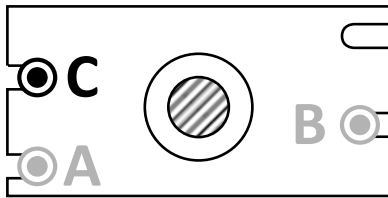

Figure displays the Button End of Cable C in its slot on the Weldment Plate.

View is from Front of Lift looking back towards the Power Post. Not to scale. Not all components shown.

2. Cable C needs to go around the Cable Sheaves at the Rear of the Lift and head back towards the Front of the Lift, so route Cable C around the Cable Sheaves already in place, then pull the Threaded end back towards the Weldment Plate.
3. Put Rear Sheave C in place, then make sure Cable C is seated in Rear Sheave C.
4. Pull the Threaded end of Cable C all the way to the Front of the Lift, then push the Threaded end into the Window, heading it towards the Front Offside Post.
5. Pull the Threaded end out of the Crosstube at the bottom of the Gusset at the Front Offside Post. Let the Threaded end hang out of the Crosstube for now.
6. Put Front Sheave C into place, then make sure Cable C is seated in Front Sheave C.
7. Remove the Cable Lock Pin on the bottom of the Gusset on the Front Offside Post.
8. Route the Threaded end of Cable C **under** the Gusset Sheave, then up towards the Top Cap at the top of the Front Offside Post.

When you route it up, it **must** be between the Gusset Sheave and the Slack Safety Sheave.

Important: When routing a Cable in its Post, the Cable must go **under** the Gusset Sheave and then, when it heads up towards the top of the Post, it must be on the side of the Slack Safety Sheave. If the Cable is **not in this exact location**, the Slack Safeties will **not** work correctly.

9. Push the Threaded end of Cable C through the Top Cap and **hand tighten** it in place with the Nut you removed just before routing the Cable.

You only want to hand tighten the Nut at this point so that there is a little play in the cabling. We will securely tighten all four Nuts later in the installation procedure.

Note: The Threaded end of Cable C should go just a little bit through the Top Cap. If it is too long or way too short, you probably have the wrong Cable. If it is just a few inches short, then the Piston on the Hydraulic Cylinder was probably not pulled out far enough.

10. Reinstall the Cable Lock Pin near the bottom of the Crosstube Gusset.

Cable C is now correctly routed to the Front Offside Post.

To route Cable D to the Front Powerside Post:

1. Find Cable D, unscrew the Nut from the Threaded end, slip the Button end past the Retaining Plate and into its slot on the Weldment Plate, then route the Threaded end towards the Rear of the Lift.

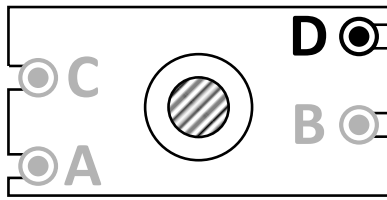

Figure displays the Button End of Cable D in its slot on the Weldment Plate.

View is from Front of Lift looking back towards the Power Post. Not to scale. Not all components shown.

2. Cable D is routed around the Cable Sheaves at the Rear of the Lift and head back towards the Front of the Lift, so route Cable D around the Cable Sheaves already in place, then pull the Threaded end back towards the Weldment Plate.
3. Put Rear Sheave D in place, then make sure Cable D is seated in Rear Sheave D.
4. Pull the Threaded end of Cable D all the way to the Front of the Lift, then push the Threaded end into the Window and towards the Front Powerside Post.
5. Pull the Threaded end out of the Crosstube at the bottom of the Gusset. Let the Threaded end hang out of the Crosstube for now.
6. Put Front Sheave D into place on top of Front Sheave C, then make sure Cable D is seated in Front Sheave D.
7. Remove the Cable Lock Pin on the bottom of the Gusset on the Front Powerside Post.
Keep it handy; you will be putting it back in place soon.
8. Route the Threaded end of Cable D **under** the Gusset Sheave, then up towards the Top Cap at the top of the Front Powerside Post.

When you start routing the Cable up, it **must** be between the Gusset Sheave and the Slack Safety Sheave.

Important: When routing a Cable in its Post, the Cable must go **under** the Gusset Sheave and then, when it heads up towards the top of the Post, it must be on the side of the Slack Safety Sheave. If the Cable is **not in this exact location**, the Slack Safeties will **not** work correctly.

9. Push the Threaded end of Cable D through the Top Cap and **hand tighten** it in place with the Nut you removed just before routing the Cable.

You only want to hand tighten the Nut at this point so that there is a little play in the cabling. We will securely tighten all four Nuts later in the installation procedure.

Note: The Threaded end of Cable D should go just a little bit through the Top Cap. If it is too long or way too short, you probably have the wrong Cable.

10. Reinstall the Cable Lock Pin near the bottom of the Crosstube Gusset.

Cable D is now correctly routed to the Front Powerside Post.

To finish the Cable routing:

1. Lubricate both Sheave Pins with a Red Lithium Grease and return the Pins into place. Insert and tighten the Sheave Pin Lock Screw.

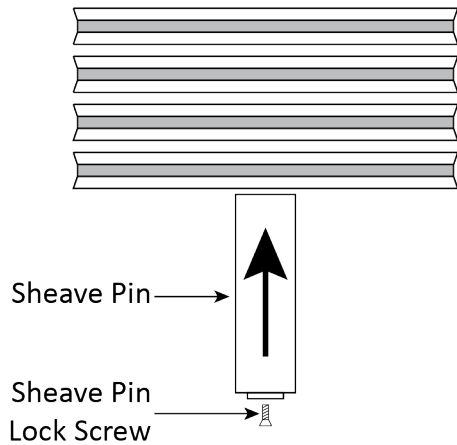

Using a Red Lithium Grease Lubricate each Sheave Pin Prior to inserting through the Sheaves. Figure displays Sheave Pin being installed into the four Cable Sheaves at the rear of the Lift.

Not to scale. Not all components shown.

It may be necessary to move the Cable Sheaves around to get the Sheave Pins back into place; they will not slide in until all the Cable Sheaves are properly aligned.

2. Go back and verify that each Cable is properly routed up its Post between the Slack Safety Sheave and the Gusset Sheave.
3. Verify each Cable carefully to ensure each one is seated in the middle of each Sheave (Cable Sheave and Gusset Sheave) that it passes through.
If you find one that is not seated correctly, adjust it until it is.
4. Check all four Cable Lock Pins (at the bottom of each Cross Tube Gusset) to ensure they are securely in place with the Cables **above** them.
5. Adjust and tighten each Cable Nut until a minimum 1 in. of thread is exposed above the nut.
6. Cable routing is now complete.

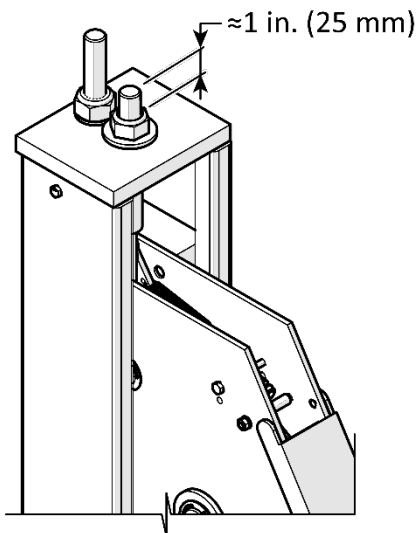

WARNING

When a Lift Cable adjusting nut bottoms out on the threaded end of the Cable Connector and there is still slack in the cables, the cables have stretched beyond their safe useful length and must be replaced with factory approved Cable Assemblies. Never install washers, spacers, or other devices to “shorten” the effective cable length. Damage may occur to the Lift and/or severe injury to those nearby.

Install the Power Unit

This section describes how to **install**, but not make the electrical connections to the Power Unit for your Lift. An Electrician is **not** required to mechanically install the Power Unit; one is required to connect the Power Unit to its power source.

The Power Unit **must** be installed on the Power Post; attach it to one of the two Mounting Brackets, whichever is more convenient for the installation.

Important: Many people install the Flex Tube Bracket Plate and/or the Zero Angle Bracket at the same time as they install the Power Unit. Review [Installing the Flex Tube](#) and [Installing the Pushbutton Air Valve](#) for more information to see if this makes sense for your installation.

 **DANGER** Risk of explosion: The Power Unit has internal arcing or parts that may spark and should not be exposed to flammable vapors. Motor should not be located in a recessed area or below floor level. Never expose the Power Unit motor to rain or other damp environments. Damage to the motor caused by water is **not** covered by the warranty.

The Hydraulic Fluid reservoir on the Power Unit must be filled with Hydraulic Fluid or automatic transmission fluid before you begin normal operation with the Lift. **When you receive the Lift, the fluid reservoir is empty.** The Power Unit will not work correctly until it is filled with approved Hydraulic Fluid.

Approved fluids are any general purpose ISO-32, ISO-46, or ISO-68 hydraulic fluid, approved automatic transmission fluids such as Dexron III, Dexron VI, Mercon V, Mercon LV, or any synthetic multi-vehicle automatic transmission fluid.

 **WARNING** Do not run your Power Unit without Hydraulic Fluid; you will damage it.

Even though you are not connecting the Power Unit at this point, you can fill the Hydraulic Fluid reservoir with fluid.

To install the Power Unit:

1. Locate the four supplied Hex Head Bolts, Flat Washers, and Nyloc Nuts.
2. Line up the holes on the Power Unit Back Plate with the four holes in the Mounting Bracket you want to use.

If you are going to install the Flex Tube Bracket Plate and/or the Zero Angle Bracket at the same time as the Power Unit, now is the time to put those into place.

There are multiple locations on the Back Plate of the Power Unit that you can use to attach to the Mounting Bracket. Choose the ones that best center the Power Unit on the Mounting Bracket.



Tip

The Power Unit is heavy. BendPak recommends having one person hold the Power Unit while another person bolts it into place.

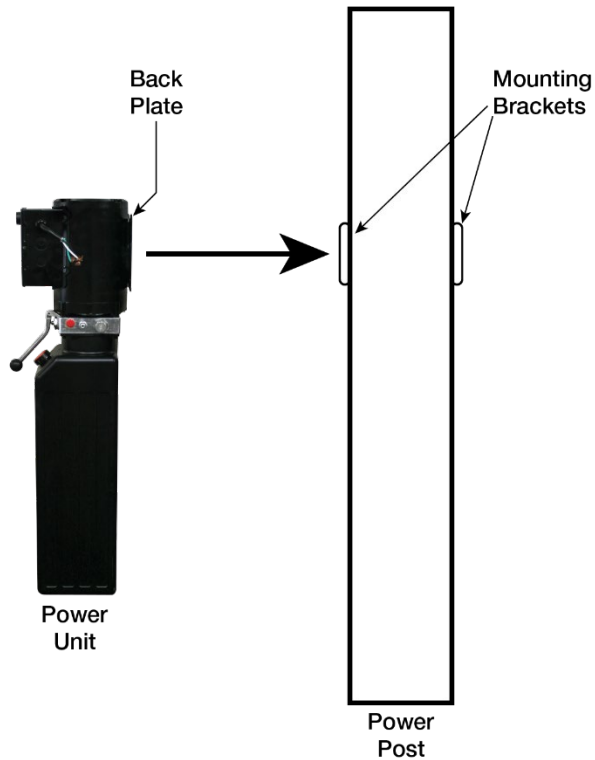

Figure not to scale. Not all components shown.

3. Connect the Power Unit to the desired Mounting Brackets on the Power Post.
4. Fill the Hydraulic Reservoir on the Power Unit with approved fluids.

The Hydraulic Reservoir holds approximately 3.6 gallons (14 liters). Use care to keep the fluid clean when filling the reservoir.

Approved fluids are any general purpose ISO-32, ISO-46, or ISO-68 hydraulic fluid or approved automatic transmission fluids such as Dexron III, Dexron VI, Mercon V, Mercon LV, or any synthetic multi-vehicle automatic transmission fluid.

Do not connect the Power Unit to a power source at this point.

Install the Flex Tube

Once the Power Unit is installed, you can install the second end of the Flex Tube (the other end was connected to the Powerside Runway earlier in the installation).

The Flex Tube consolidates and protects the lines routed from under the Powerside Runway: the Air Line, the Return Line, and the Hydraulic Hose.

To install the Flex Tube, the Flex Tube Bracket Plate and the Flex Tube Angle Plate must be installed.

Flex Tube Bracket Plate

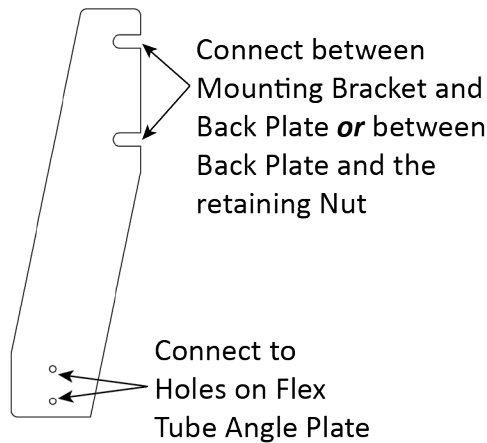

Flex Tube Angle Plate

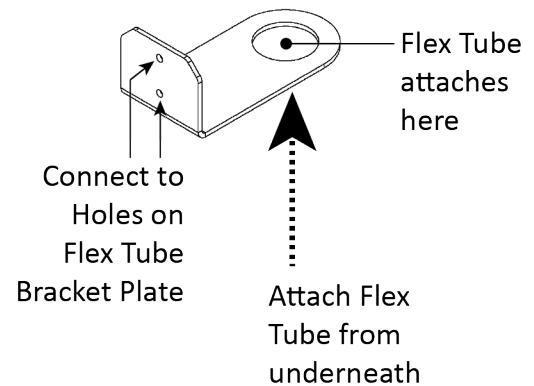

The components involved include:

- **Flex Tube.** Protects the Air Line, the Return Line, and the Hydraulic Hose. Connects to the hole on the Flex Tube Angle Plate from underneath.
- **Flex Tube Bracket Plate.** The two notches at the top attach near the Mounting Bracket on the Power Post. The two holes at the bottom connect to the Flex Tube Angle Plate.
- **Flex Tube Angle Plate.** Attaches to the Flex Tube Bracket Plate via two holes, giving you the flexibility to connect it on either side. Includes the hole to which the Flex Tube connects.

BendPak recommends orienting the Flex Tube so that the lines coming out of it are near where they connect on the Power Unit and to the Pushbutton Air Valve.

Install the Pushbutton Air Valve

Once the Power Unit and the Flex Tube are installed, you can install the Pushbutton Air Valve, which requires the Zero Angle Bracket (which may already have been installed).

The Pushbutton Air Valve is used to lower the Runways. It can go on either side of the Power Unit, whichever is easier to access for the Lift operator.

Once the pushbutton is in place, you need to connect it to the Air Line (which is coming out of the Flex Tube) on one end and the customer-supplied air pressure on the other end. **A minimum air pressure of 50 psi at 3 cfm is required. Air pressure should never exceed 125 psi.**

The figure below details the Zero Angle Bracket connection.

Zero Angle Bracket

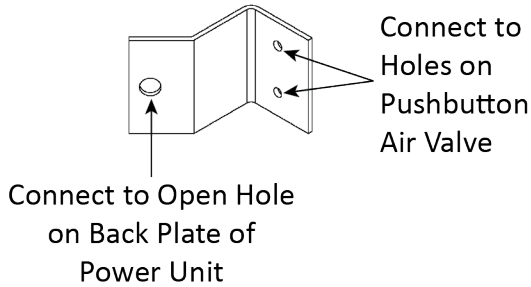

Pushbutton Air Valve

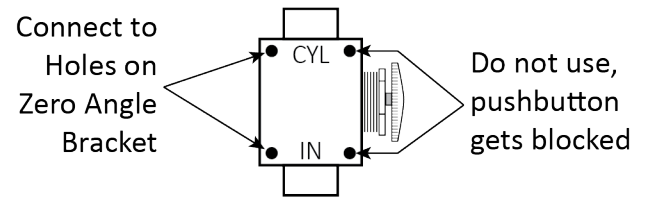

The components involved include:

- **Zero Angle Bracket.** Attaches at the Mounting Bracket on the Power Post or to other available holes on the Back Plate of the Power Unit. Holds the Pushbutton Air Valve, so be sure to orient the Zero Angle Bracket so that the Lift operator can easily reach the Pushbutton Air Valve.
- **Pushbutton Air Valve.** Used to lower the Runways.
- **Air Line Compression Elbow Fitting.** Connects the Pushbutton Air Valve to the Air Line coming out of the Flex Tube.
- **Straight Expander Fitting.** Connects the Pushbutton Air Valve to the customer-supplied air pressure. A minimum air pressure of 50 psi / 3 cfm is required.

To install the Pushbutton Air Valve:

1. Find the necessary components: Zero Angle Bracket, Pushbutton Air Valve, Air Line Compression Elbow Fitting, and Straight Expander Fitting.

2. Connect the Zero Angle Bracket at the desired location (if it has not already been connected).

It can attach to an available hole on the Back Plate of the Power Unit or to one of the Bolts that connect the Power Unit to the Mounting Bracket on the Power Post.

The best location is one that is visible and easily reached by the Lift operator.

3. Connect the Pushbutton Air Valve to the Zero Angle Bracket.

Use the two holes on the Pushbutton Air Valve on the side away from the actual pushbutton. If you use the holes next to the pushbutton, the Zero Angle Bracket interferes with the pushbutton when you try to use it.

The figure to the right details the Pushbutton Air Valve and its connections.

4. Connect the Air Line Compression Elbow Fitting and the Straight Expander Fitting to the appropriate locations on the Pushbutton Air Valve.

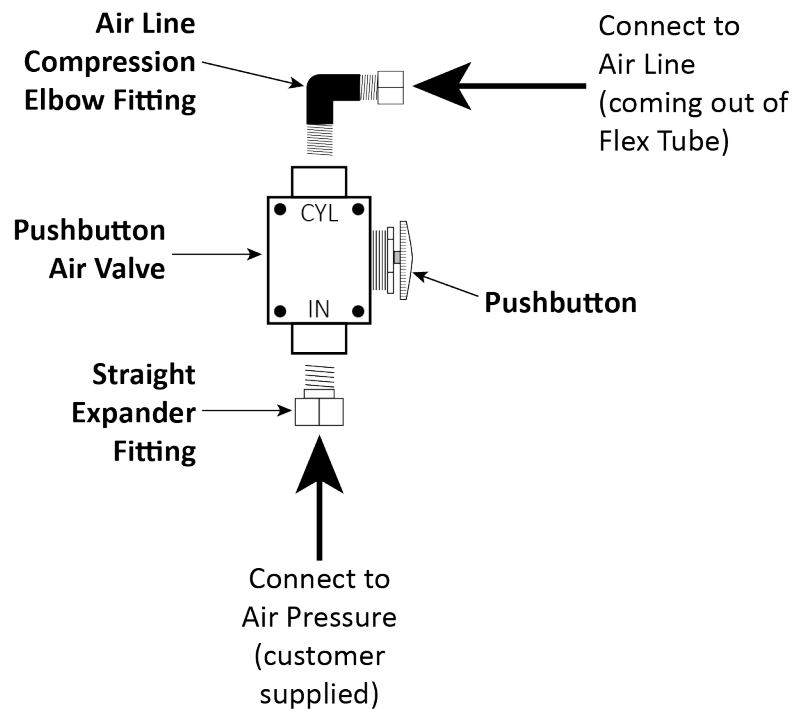

The elbow fitting connects to the opening labelled **CYL**. The straight fitting to the opening labelled **IN**. See the drawing above.

5. Attach the Air Line (coming out of the Flex Tube) to the compression fitting on the elbow fitting and the customer-supplied air to the straight fitting.

Important: The Return Line also comes out of the Flex Tube and is the same kind of tubing as the Air Line. **Do not attach the Return Line to the Pushbutton Air Valve by mistake.** Double check to make sure you are attaching the Air Line to the Pushbutton Air Valve.

For the customer-supplied air pressure, a minimum of 30 PSI / 3 CFM is required.

Connect the Return Line

The Return Line connects to the Hydraulic Return connector on the Power Unit.

One end of the Return Line is already connected to the Hydraulic Cylinder; the other end should be coming out of the Flex Tube.

To attach the Return Line to the Power Unit:

1. Locate the Hydraulic Return connector on the Power Unit and remove the Shipping Plug.

There is only one Hydraulic Return connector on the Power Unit.

2. Connect and tighten the threaded end of the remaining Elbow Compression Fitting to the Hydraulic Return connector.

For information about connection compression fittings, refer to [Working with Compression Fittings and Tubing](#).

3. Find the Return Line coming out of the Flex Tube and securely connect it to the Elbow Compression Fitting.

Important: The Air Line, at one point, was also coming out of the Flex Tube and it uses the same kind of tubing as the Return Line. The Air Line should have been connected in the previous section, but if it was not, make sure you are attaching the Return Line to the Power Unit and not the Air Line. **Do not attach the Air Line to the Power Unit by mistake.**



IMPORTANT! PLEASE READ NOW



Hydraulic Fluid Contamination

Hydraulic Fluid Contamination poses a **serious** issue for your Lift; contaminants such as water, dirt, or other debris can get into the Hydraulic Hoses and Fittings on your Lift, making your new Lift inoperable.

Your Lift is shipped with clean components; however, BendPak strongly recommends that you take secondary precaution and clean all Hydraulic Hoses and Fittings prior to making connections. It is better and less costly to take these extra steps now so that you do not need to take your Lift out of service later to fix issues that could have been prevented at the time of installation.

There are several ways to clean Hydraulic Hoses and Fittings:











- **Compressed Air.** Use an air compressor to blow out contaminants from each Hydraulic Hose and Fitting prior to installation. Clean, dry air is preferred. Wear eye protection (safety glasses, goggles, or face shield) when using compressed air for cleaning. Never point an air hose nozzle at any part of your body or any other person.
- **Fluid Flushing.** If the Hydraulic Fluid is clean and compatible with the system fluid, you can flush Hoses and Fittings to create turbulent flow and remove particulates. Always ensure that the fluid itself is contaminant-free.

Some additional steps that will help keep the Hydraulic Fluid clean:

- **Remove old thread seal tape.** Some ports on the Hydraulic Cylinders are shipped with temporary plugs secured with thread seal tape, so make sure to thoroughly remove any leftover thread seal tape that may inadvertently enter the Hydraulic System.
- **Use a liquid thread sealant only.** Teflon paste-type thread sealant or Loctite™ 5452 thread sealant is recommended for all NPT Fittings. Do not over tighten NPT Fittings or they may crack. Never use thread seal tape on JIC Fittings or ORB O-Ring Fittings.
- **Always use clean equipment.** If you use a dirty bucket or funnel to transfer the Hydraulic Fluid into the Hydraulic Fluid Reservoir, the contaminants will likely be introduced into the Fluid. When using cleaning rags, use a lint-free rag.
- **Proper storage.** Keep the Hydraulic Fluid sealed in its container until ready for use; store the Fluid in a clean, dry, and cool area.
- **Cover the Hoses and Fittings.** Before installation, do not leave the ends of the Fittings exposed; the same applies for the Hydraulic Hoses. Generally, keep the Hydraulic Hoses and Fittings capped and kept clean in a clean area until ready for use.
- **Filter the new Hydraulic Fluid.** Just because it is new does not necessarily mean it is *clean*. Use an offline filtration cart or kidney loop system to make sure the Hydraulic Fluid is clean before being transferred into the Hydraulic Fluid Reservoir (even using a heavy-duty nylon mesh screen is better than trusting what is left at the bottom of the barrel).
- **Avoid mixing different types of Hydraulic Fluid.** If Hydraulic Fluid needs to be replaced, make sure to flush the Hydraulic System of the old Hydraulic Fluid before you add the replacement Fluid; do not mix the two together.

Hydraulic System Warnings

Before applying power to the Hydraulic System note the following Warnings:

-  **WARNING** Failure to observe these warnings can result in serious personal injury including, in rare cases, death.
-  **WARNING** The Hydraulic hoses and connections **must** be inspected before any attempt to raise a Vehicle is made.
-  **WARNING** Verify all Hydraulic Hose connections and fittings, including unused auxiliary port plugs on the Power Unit, the Flow Divider, the Cylinders and anywhere else in the Hydraulic System are tightened.
-  **WARNING** The Power Unit is a Hydraulic Pump capable of developing pressures in excess of 5,000 psi (345 BAR). A pressure relief valve is used to set the pressure at the desired level. Tampering with, adjusting, modifying, or removing the relief valve is extremely dangerous and is not permitted. Only trained Hydraulics technicians should adjust the relief valve, using calibrated hydraulic pressure gauges to ensure the proper pressure setting is achieved.
-  **WARNING** Changes to the output pressure may render the power unit incompatible with pressure limitations of other components in the hydraulic circuit. This may cause catastrophic failure of those components, and could result in property damage, serious personal injury, or death.
-  **WARNING** The Hydraulic System can contain high pressures which, if suddenly released, can cause severe injury or death.
-  **WARNING** Do **not** attempt to connect or disconnect Hydraulic Hoses while the equipment is loaded or while a Vehicle is on the Lift, or the Hydraulic System is under pressure.
-  **WARNING** Keep bare hands away from Hydraulic Fluid; always wear gloves when handling Hydraulic Fluid, Cylinders or Hydraulic Hoses.
-  **WARNING** When handling Hydraulic Fluid, always observe the safety instructions from the manufacturer.
-  **WARNING** **Always** promptly clean any Hydraulic Fluid spills. If a leak is the source of the spill, lockout the Lift to prevent use until the Hydraulic System is repaired.
-  **WARNING** Do **not** attempt to service the Power Unit through the rear panel. Only access the Power unit through the Front of the Console.

Connect the Hydraulic Hose

The Hydraulic Hose connects to a Hydraulic Out connector on the Power Unit.

One end of the Hydraulic Hose is already connected to the Hydraulic Cylinder; the other end (the Straight end) should be coming out of the Flex Tube.

To attach the Hydraulic Hose to the Power Unit:

-
1. Locate the Hydraulic Out connector on the Power Unit you want to use and remove the Shipping Plug.
There are two Hydraulic Out connectors on the Power Unit; you can use either one.
 2. Connect and securely tighten the ORB Connector on the JCI-to-ORB Fitting to the Hydraulic Out connector you want to use.
 3. Connect and securely tighten the Hydraulic Hose coming out of the Flex Tube to the JIC Connector of the JCI-to-ORB Fitting.

Contact the Electrician

Following are the installation tasks that **require** a licensed Electrician.

⚠ DANGER A licensed Electrician must complete all wiring.

The Electrician will:

1. Determine the circuit breaker required based on the actual power unit and data on the motor delivered.
2. Determine if the existing circuit breaker and wire size is adequate based on additional loads already on the circuit and distance from the service entrance.
3. Determine the proper Power Disconnect based on the motor HP.
4. Determine the proper Thermal Disconnect based on the motor HP.
5. Determine if the voltage and electrical service at that location is sufficient for the additional load to drive the Power Unit.
6. **Connect a 220 VAC power source to the Power Unit.** A power source is required. Refer to **Connecting the Power Source** for more information.
7. **Install a Power Disconnect Switch.** Ensures you can quickly and completely interrupt electrical power to the Lift in the event of an electrical circuit fault, emergency, or when equipment is undergoing service or maintenance. You must put it within sight and easy reach of the Lift operator. Refer to **Install a Power Disconnect Switch** for more information.
8. **Install a Thermal Disconnect Switch.** Ensures the equipment shuts down in the event of an overload or an overheated motor. Refer to **Install a Thermal Disconnect Switch** for more information. Note that the Power Unit that comes with the Lift is **not** thermally protected.

The Electrician is responsible for providing:

- an appropriate plug to attach to the Power Unit
- an appropriate cable routed from the power source to the plug or junction box on the Power Unit
- a Power Disconnect Switch
- a Thermal Disconnect Switch

Refer to **Wiring Diagrams** for additional wiring information.

Additional information is supplied in the sections describing these tasks.

Connect the Power Source

The standard Power Unit for this Lift is a 208-240 VAC, single phase, 50/60 Hz., 2 HP at approx. 7 amps. The Power Unit must be connected to an appropriate power source.

The Power Unit may be one of several types. The differences lay in the power required and minor location differences for some components and controls.

Refer to **Wiring Diagrams** for wiring information.

⚠ DANGER A licensed Electrician **must** perform all wiring in accordance with national and local electrical codes. Do not perform any maintenance or installation on the Lift without first verifying that main electrical power has been disconnected from the Lift and **cannot** be re-energized until all procedures are complete.

Important electrical information:

- Improper electrical installation can damage the Power Unit motor; this is not covered under warranty.
- Use a separate circuit breaker for each Power Unit.
- Protect each circuit with a time-delay fuse or circuit breaker. For a 220 VAC, single phase circuit, use a 25 amp circuit breaker or time delayed fuse.

The figure below displays **Power Unit (5585785)** hydraulic connections and controls.

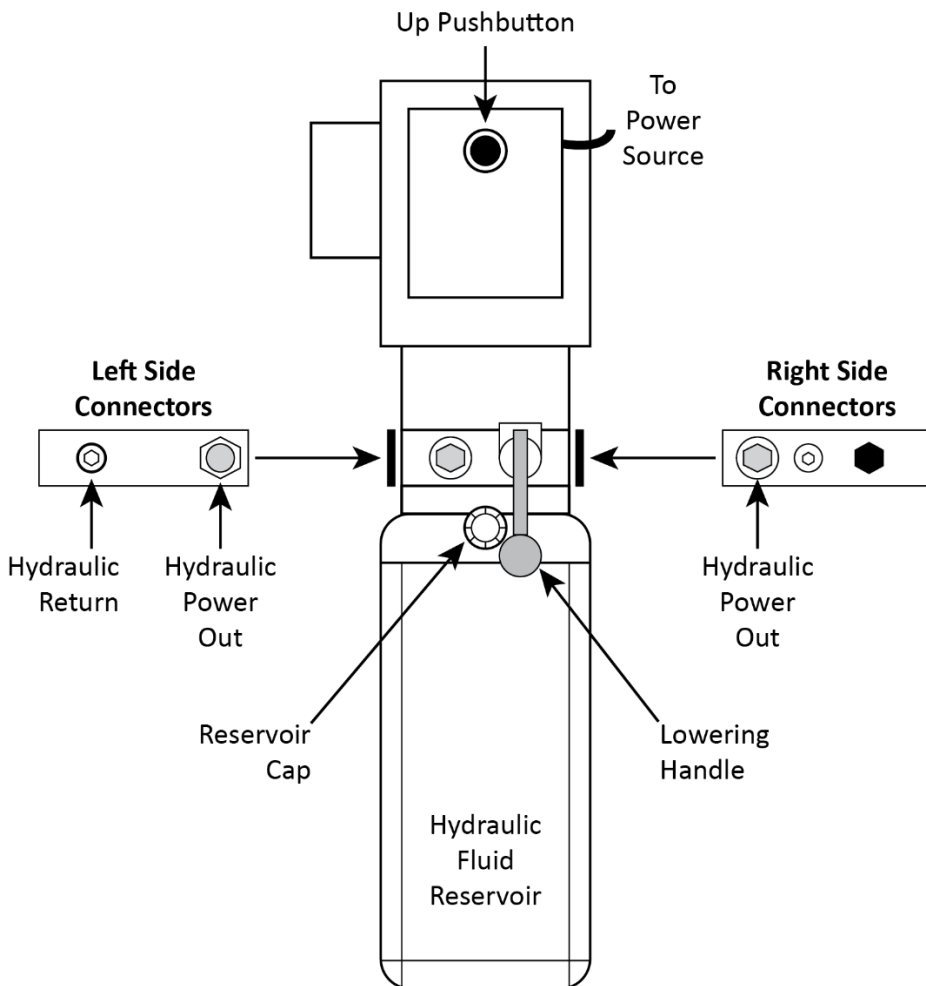

The figure below displays **Power Unit (5585175)** connections.

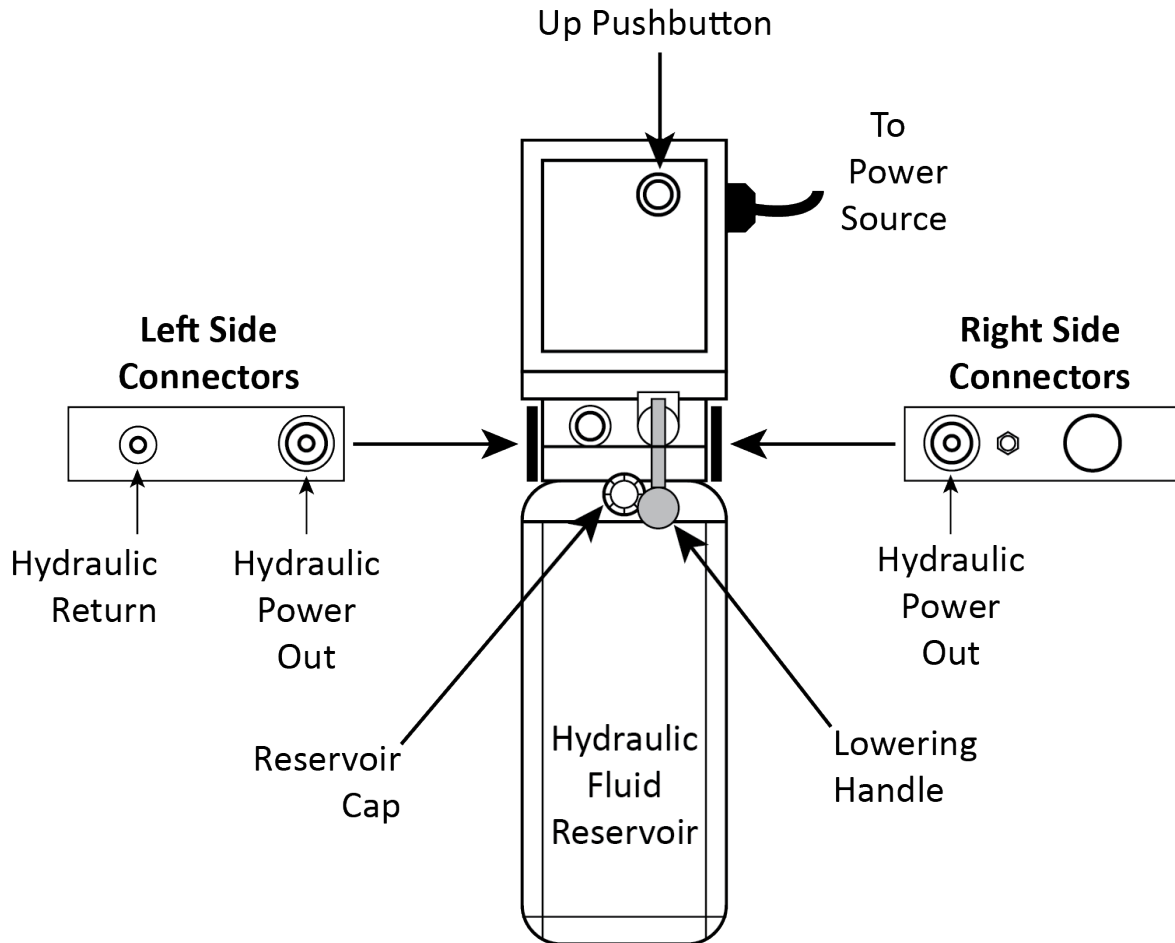

To connect the Lift to a power source:

9. Have a licensed Electrician connect an appropriate plug to the wiring exiting the top of the Power Unit (labelled **To Power Source** in the drawings above). A plug is **not** supplied with the Lift. Or connect directly to facility power protected by an appropriate circuit breaker or fuse.
10. Connect the power source cable to the plug you just connected.
Refer to **Wiring Diagrams** for proper wiring information.
The power source cable is **not** supplied with the Lift.
11. Double check to make sure the Hydraulic Fluid Reservoir has an adequate supply of fluid.
Do not run the Lift without adequate supply of Hydraulic Fluid; you will damage the Power Unit.

Install a Power Disconnect Switch

⚠ WARNING A main Power Disconnect Switch is **not** provided with this equipment.

A Power Disconnect Switch is a National Electrical Code (NEC) requirement. They are designed to interrupt electrical power in the event of an electrical circuit fault, emergency, or when equipment is undergoing service or maintenance.

BendPak strongly recommends that you install a Power Disconnect Switch that is UL listed and properly rated for the incoming power.

⚠ DANGER All wiring **must** be installed and connected by a licensed Electrician.

Your Power Disconnect Switch must be readily accessible and installed so that it is in easy reach of the Lift operator. It must be clearly and legibly marked to indicate its purpose.

The drawing to the right shows a toggle Power Disconnect Switch between the Lift's power source and its Power Unit. A quick flip of the switch immediately cuts power to the Lift.

Make sure to have a licensed Electrician install the Power Disconnect Switch.

Make sure the Electrician selects a UL-listed Power Disconnect Switch.

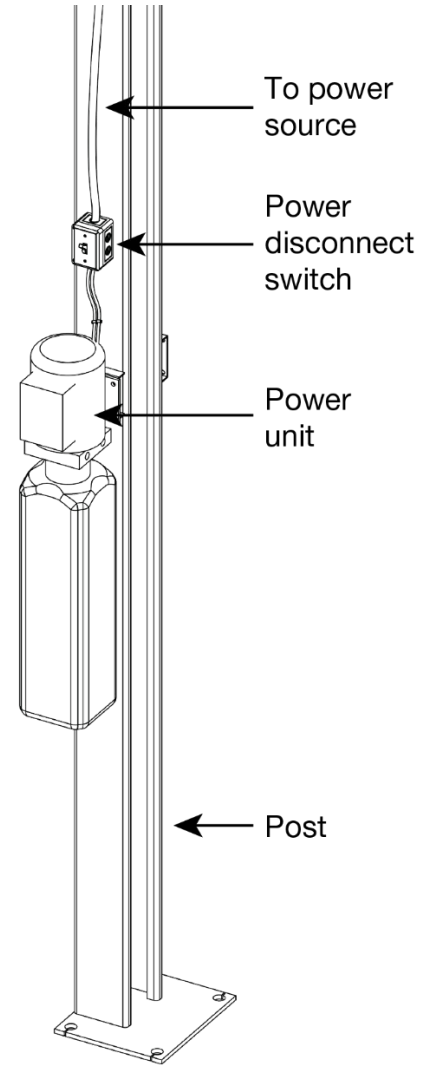

Install a Thermal Disconnect Switch

⚠ WARNING The Lift's motor does **not** include thermal overload protection.

Connect a Thermal Disconnect Switch or overload device to the motor that will make sure the equipment shuts down in the event of an overload or an overheated motor.

⚠ DANGER A licensed Electrician must perform all wiring.

High running electrical current that exceeds the motor's full load amperage (FLA) rating may result in permanent damage to the motor.

BendPak strongly recommends you **not** exceed the rated duty cycle of the Lift's motor.

Anchor the Posts

If you have not done so already, you need to anchor the Lift's four Posts. Install one Anchor Bolt in each corner of each Base Plate, 16 Anchor Bolts total.

Concrete specifications are:

- **Depth:** 4.25 inches thick
- **PSI:** 3,000 PSI, minimum
- **Cured:** 28 days, minimum

Anchor Bolt specifications are:

- **Length:** 4.75 inches
- **Diameter:** .75 inch
- **Effective embedment:** 2.75 inches, minimum
- **Anchor torque:** 85-95 pound feet (do *not* Torque less than 80 or more than 105)

⚠ WARNING Your Concrete and Anchor Bolts **must** meet these specifications. Only install your Lift on a Concrete surface. If you install a Lift on asphalt or any other surface, or your Concrete or Anchor Bolts do not meet these specifications, it could lead to product damage, vehicle damage, personal injury, or even loss of life.

BendPak Lifts are supplied with installation instructions and concrete fasteners meeting the criteria as prescribed by the American National Standard "Automotive Lifts – Safety Requirements for Construction, Testing, and Validation" ANSI/ALI ALCTV.

⚠ WARNING Use only the Anchor Bolts that came with your Lift. If you use components from a different source, you void your warranty and compromise the safety of everyone who installs or operates the Lift.

Lift buyers are responsible for conforming to all regional, structural, and seismic anchoring requirements specified by any other agencies and/or codes, such as the Uniform Building Code and/or International Building Code.

To anchor the Posts:

1. Locate the hardware you will need: four Anchor Bolts, four Nuts, and four washers **per Post**.
2. Using the Base Plates as guides, drill the holes for the Anchor Bolts—one hole in each corner of the Base Plate, so four holes total per Base Plate.

Drill in straight, in the center of the hole; do not let the drill wobble.

Use a carbide bit (conforming to ANSI B212.15).

The diameter of the drill bit must be the same as the diameter of the Anchor Bolt. If you are using a $\frac{3}{4}$ inch diameter Anchor Bolt, for example, use a $\frac{3}{4}$ inch diameter drill bit.

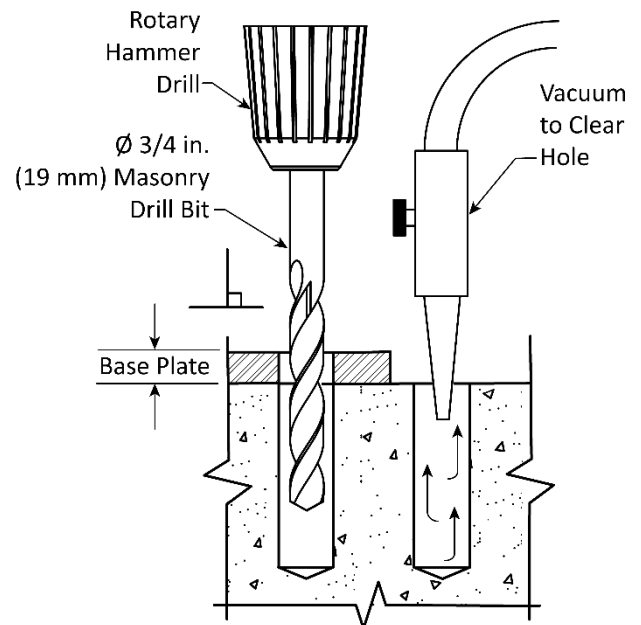

3. Vacuum each hole clean.

BendPak recommends using a vacuum to thoroughly clean the hole. You can also use a wire brush, hand pump, or compressed air; **make sure to thoroughly clean each hole.**

Do **not** ream the hole. Do **not** make the hole any wider than the drill bit made it.

Important: The holding strength of an Anchor Bolt is partially based on the how cleanly the Expansion Sleeve presses against the Concrete. If the hole is dirty, the Expansion Sleeve does not press as cleanly, which means less holding strength. If the hole is too wide, the Expansion Sleeve does not press against the Concrete with as much force, again resulting in less holding strength.

4. Make sure the Washer and Nut are in place, then insert the Anchor Bolt into the hole.

The Expansion Sleeve of the Anchor Bolt may prevent the Anchor Bolt from passing through the hole in the Base Plate; this is normal. Use a hammer or mallet to get the Expansion Sleeve through the Base Plate and into the hole.

Even using a hammer or mallet, the Anchor Bolt should only go into the hole part of the way; this is normal. If the Anchor Bolt drops in with little or no resistance, the hole is too wide.

Once past the hole in the Base Plate, the Anchor Bolt eventually stops going down into the hole as the Expansion Sleeve contacts the sides of the hole; this is normal.

5. Hammer or mallet the Anchor Bolt the rest of the way down into the hole.

Stop when the Washer is snug against the Base Plate.

6. Plumb each Post; install any required Shims.

Do not shim a Post more than half an inch using the provided Shims. A maximum of 2 inches is possible by ordering optional Shim Plates.

Contact BendPak at **(800) 253-2363**, select option 7 then 5 to order. Please have the model and serial number of your Lift available.

Take your time while plumbing and shimming the Posts; **it is important to make the Lift level as possible.**

7. Wrench each Nut **clockwise** to the recommended installation torque, 85-95 pound feet, using a Torque Wrench.

Important: Do **not** use an impact wrench to torque the Anchor Bolts.

Wrenching the Nut forces the Wedge up, forcing out the Expansion Sleeve and pressing it tightly against the Concrete.

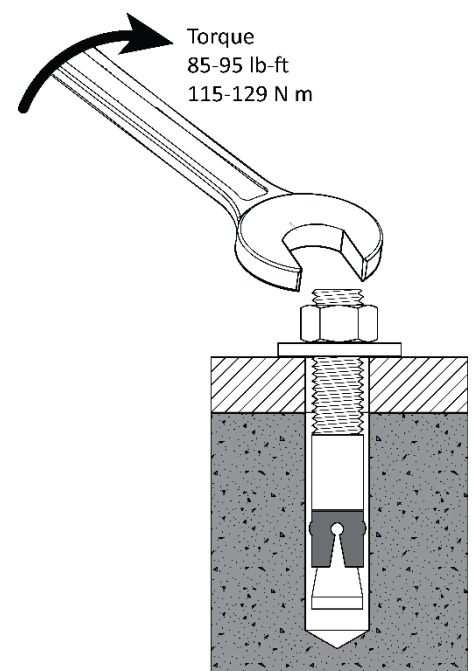
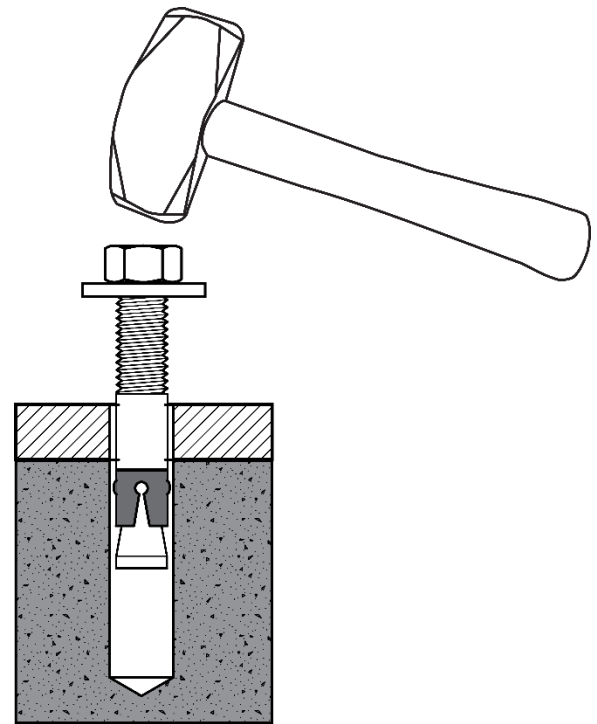

Final Leveling

Because you are installing an Alignment Lift, it is particularly important that the Lift's Runways are level, or as close to level as possible. The following procedure describes how to fine tune how level your Lift is. The goal is that the four Safety Locks on the Lift engage at the same time.

To complete the final leveling on the Lift:

1. Raise your Lift and then lower onto the first Safety Lock position (the primary Safety Locks, not the Slack Safety Locks).
2. Use a transit level or other leveling mechanism to evaluate how level the Posts and Runways are to each other.
3. If you need to adjust a Runway, use the Top Nut and Stop Nut on the Top Cap of each Post to adjust the Ladder in that Post (which impacts the levelness of the Runway and when the Safety Locks engage).
4. Raise the Lift to its full height, listening as the Safety Locks engage.

If the Safety Locks are engaging at roughly the same time, no further adjustments are necessary.

If the Safety Locks are not engaging at the same time, check the leveling, make necessary adjustments, and then raise the Lift again and listen as the Safety Locks engage.

5. ***When you are satisfied the Lift is level, firmly secure the Top Safety Ladder Nut and Jam Nut at the top of each Post.***

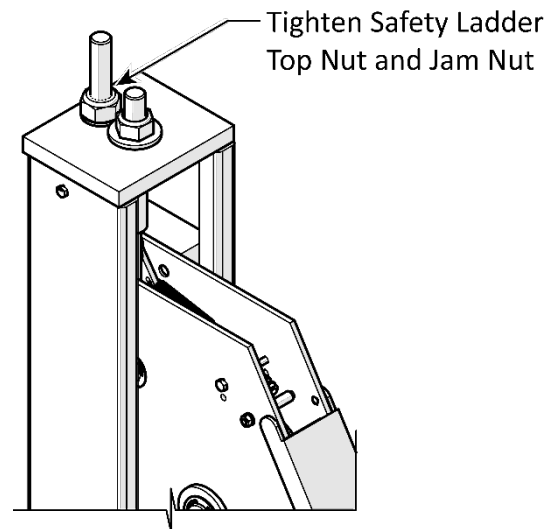

Installing Accessories

The accessories available for your Lift include:

- **Tire Stops.** Installed at the Front of the Lift. Hold the front Tires of the vehicle in position. Always chock the rear tires, to prevent the vehicle from moving while on the Lift.
- **Ramps.** Installed at the Rear of the Lift. Allow vehicles to be easily driven onto the Runways.
- **Alignment Turn Plates.** Installed at the Front of the Runways. Used for wheel alignments.

Tire Stops

Tire Stops are bolted onto the Front of the Lift. They prevent the tires of the vehicle on the Lift from going too far forward.

To install the Tire Stops:

1. Locate the four M14 by 2 by 40L Hex Head Bolts, Washers, and Nuts that you will need (two sets per Tire Stop).
2. Put one Tire Stop in position over the holes in the Runway, put the Bolt through the Tire Stop and the holes in the Runway, then secure the Tire Stop with the Washer and Nut on the underside of the Runway.

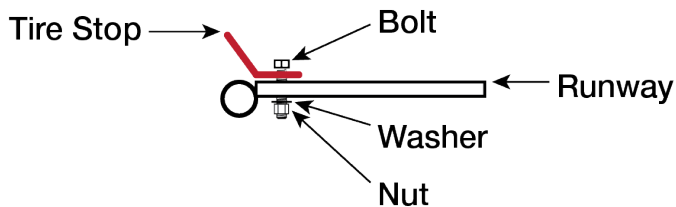

Note: Make sure to orient the Tire Stop so that it is sloping away from the Runways. This creates an angle best suited to holding the Tire in place.

3. Repeat Steps 1 and 2 for the second Tire Stop.

Drive Up Ramps

Your Lift comes with two Ramps, which are installed onto the Rear of the Lift so that vehicles can drive onto the Runways.

To install the Drive Up Ramps:

1. Retrieve the required components: two Ramps, two Ramp Pins, and four 18 mm Rotor Clips.
2. Put a Drive Up Ramp into position on the end of a Runway at the Rear of the Lift, with the tube on the bottom of the Ramp between the two tubes on the end of the Runway.
3. Slide a Ramp Pin through the three tubes, then install Rotor Clips on both ends of the Ramp Pin.

Note: The Ramps are heavy and awkward to handle, consider having two people install them; one to hold the Ramp, the other to put the components into place.

4. Repeat Steps 2 and 3 for the other Ramp.

Alignment Turn Plates

Alignment Turn Plates are used for vehicle wheel alignments. They are used in conjunction with a Filler Plate to fill the lowered space at the Front of the Lift.

Note: If you are going to be using your Alignment Lift for service as well as alignments, consider purchasing additional Filler Plates. You do not want the vehicles you are servicing to be sitting on the Alignment Turn Plates, which are more easily damaged than the Filler Plates. The BendPak part number for the Filler Plate is 5700238; call **(800) 253-2363**, select option 7 then 5.

To install the Alignment Turn Plates:

1. Find the required components: two Alignment Turn Plates and two Filler Plates.
2. Put one of the Alignment Turn Plates into place in the lowered space at the Front of one of the Runways.

The Alignment Turn Plate can go in either location in the lowered space; the Filler Plate goes in the other location.

Put the Alignment Turn Plate closer to the Front of the Lift (closer to the Tire Stops) if you are going to be doing alignments on vehicles with shorter wheel bases, automobiles, for example.

For vehicles with longer wheel bases (bigger trucks, for example), put the Alignment Turn Plate closer to the Rear of the Lift. This orientation prevents vehicles with longer wheel bases from hanging so far over the Front of the Lift that they interfere with using the aligner.

Neither the Alignment Turn Plate nor the Filler Plate are bolted into place, making it easier to move them when necessary.

3. Repeat Step 2 for the other Alignment Turn Plate and Filler Plate.

Apply the Anti-Slip Tape

The Anti-Slip Tape (SKU 5930195) is provided in a single roll measuring 6 in. x 24 ft. (152 mm x 7.3 m). BendPak suggests cutting the Tape into several equal lengths.

IMPORTANT! Surface preparation is important. If the runway is in poor condition with gouges, holes, or jagged edges the Anti-Slip Tape will not adhere. Lift Runways must be clean, dry, and smooth.

To apply the Anti-Slip Tape:

1. Clean the runway. Use a broom or brush to remove loose dirt and debris from the runway.
2. Thoroughly wash, rinse, and dry the runway using a mild solution of soap and clean water to remove any oils, grease, and water-soluble contamination. Dry the runway with a clean cloth and allow to air dry.
3. Cut the Anti-Slip Tape into equal pieces.
4. Verify the Runway is dry and clean. It is critical for maximum adhesion of the Anti-Slip Tape that the runway be dry, free of dirt, oils, and grease.
5. Measure and mark the runways with pencil guidelines to outline the tape installation area on the ramp. Refer to the figure on the next page for a suggested layout of the Anti-Slip Tape.

IMPORTANT! Do not install this Tape directly on the edge of a Runway. Stay at least 1 in (25 mm) away from edges. Do not attempt to bend this Tape over an edge.

6. Wash your hands. The Anti-Slip Tape's adhesive side is protected by a paper or plastic film. You will remove this film a few inches at a time to apply the Tape to the Runway.

IMPORTANT! Handle the tape by its edges. Minimize contact between the adhesive and your hands. The oils from your hands will reduce the adhesive's long-term effectiveness.

IMPORTANT! BendPak recommends two people work together to install the Tape. One person removes the backing and applies the Tape to the Runway while the second holds the Tape in place over the guidelines marked on the Runway.

7. Lay one piece of the Anti-Slip Tape on the runway and peel back about 2 inches (50 mm) of the protective film. Apply the adhesive side to the Runway inside the guidelines you created in step 5.
8. Slowly remove the film as you press the exposed Tape's adhesive side into the Runway. Work slowly and apply 2 to 5 inches at a time to stay within your guidelines.
9. After applying the Tape use a heavy rubber roller to press the Tape into the Runway and to ensure firm contact with the adhesive.
10. Apply the Anti-Slip Tape to the remaining area of the Lift's runways.

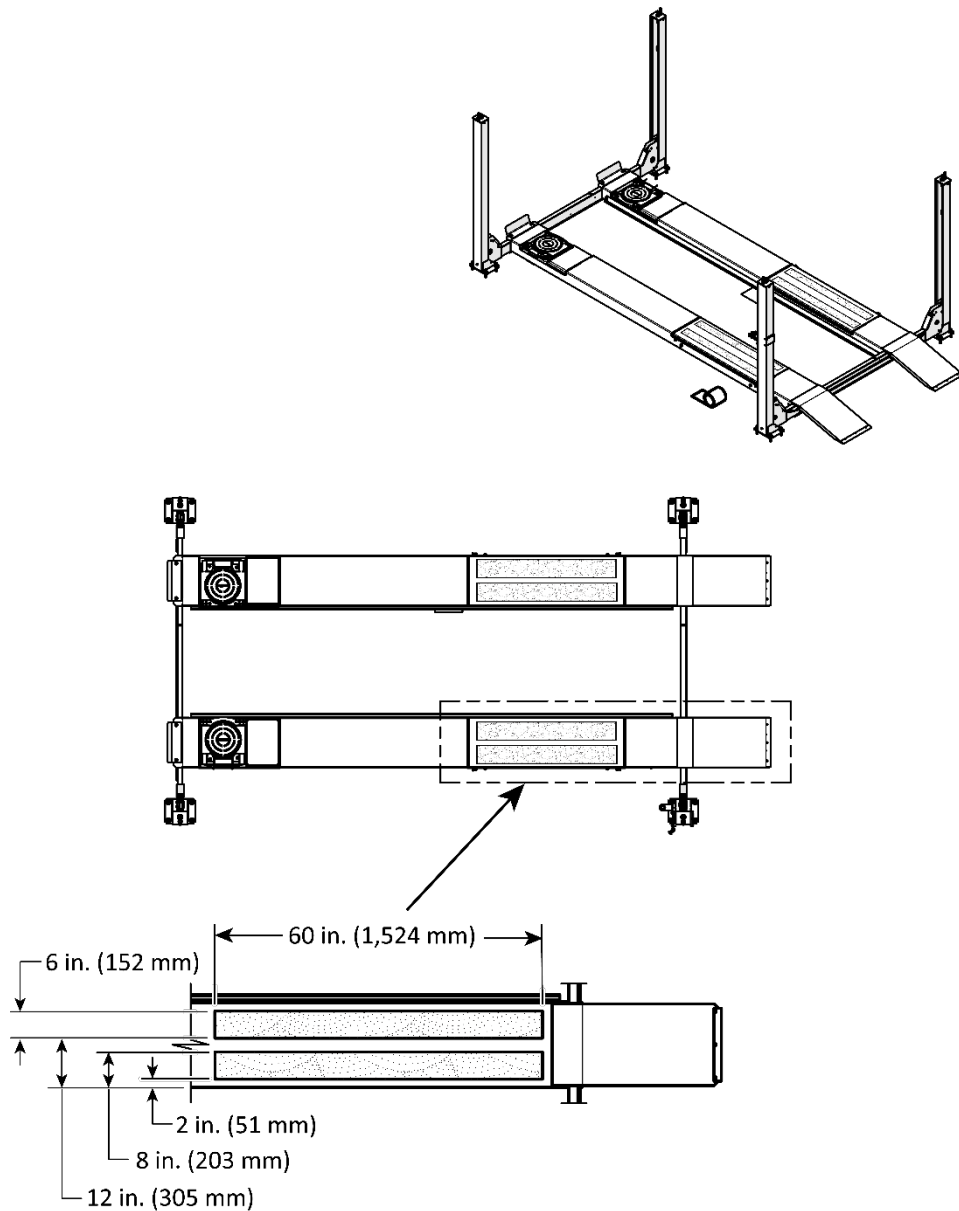

Lubricating the Lift

There are several lubrication points on the Lift.

- **Inside of the Lift Posts.** Lubricate the inside of the Lift Posts where the Slide Blocks travel with a White Lithium Grease.
- **Slip Plate.** Remove the Slip Plate and lubricate the ball casters with white lithium grease.
- **Wire Rope** is only fully protected when each wire strand is lubricated both internally and externally. Excessive wear shortens the life of wire rope. Use a wire-rope lubricant that penetrates to the core of the rope and provides long-term lubrication between each individual strand, such as 90-WT gear oil or ALMASOL® Wire Rope Lubricant. To make sure that the inner layers of the rope remain well lubricated, lubrication should be done at least every three months during normal operation.

- **All Sheaves** and guide rollers that contact moving wire rope should be given regular visual checks for surface wear and lubricated to make sure they run freely. This should be done every three months during normal operation.

For all sheave pins, use wheel bearing or red lithium grease. For all Sheaves and/or guide rollers, use 90-WT gear oil or a similar heavy lubricant, applied by any method including pump/spray dispensing, brush, hand, or swabbing. The following graphic details the lubrication points on the Lift.

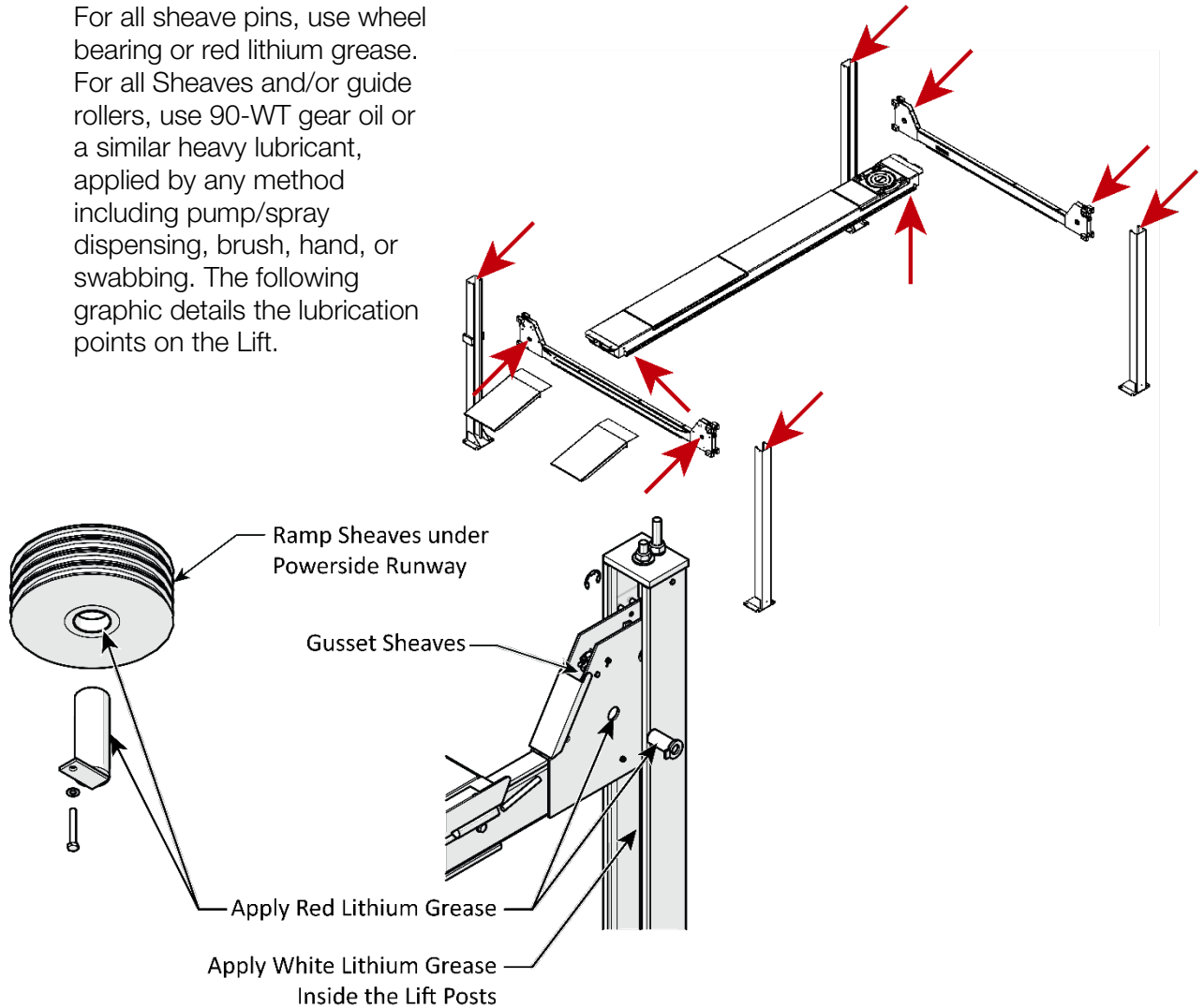

Bleeding the Hydraulic Cylinder

The Hydraulic Cylinder on the Lift is self-bleeding, which means that in most cases any air in the system can be removed by raising and lowering the Runways a few times; “bleeding” the Hydraulic System of the unwanted air.

⚠ WARNING Before performing any maintenance on your Lift (for example, bleeding the Hydraulic Cylinder or adding Hydraulic Fluid), make sure both Runways are on the ground and the power source has been disconnected.

Symptoms of air in the Hydraulic System include Runways moving erratically and/or making odd noises. These could be caused by other situations; refer to **Troubleshooting** for more information.

To bleed the Hydraulic System:

1. Raise and lower the Runways up to six times; **pause for at least one minute between each cycle.**

The Lift's motor cannot run continuously; it is designed for regular use, but not continuous use.

2. Watch the Runways as you raise and lower them.

When the Lift stops moving erratically or stops squeaking, you can stop the bleeding process.

3. Check the Hydraulic Fluid reservoir on the Power Unit.

Bleeding the Hydraulic System may significantly lower the amount of Hydraulic Fluid in the reservoir.

4. Add additional Hydraulic Fluid if necessary.

If your Lift is still moving erratically or making odd noises after bleeding the Hydraulic System, refer to **Troubleshooting** for more information.

Perform an Operational Test

BendPak strongly recommends doing an Operational Test of your Lift with a typical vehicle before starting normal service (a typical vehicle is not required but is recommended).

During the Operational Test, watch the Lift and its components and check for proper installation and operation. If you run into an issue that does not go away, refer to **Troubleshooting** for more information.

Note: Residual air in the Hydraulic System can cause the Lift to shake, move erratically, or squeak when you start using it; this is normal. If it happens, do not worry; it will go away as the Hydraulic System is self-bleeding. If it does not go away soon, try bleeding the Cylinder of air. If it still does not go away, refer to **Troubleshooting** for additional information.

To test your Lift:

1. Check the area around, above, and under the Lift for obstructions; move them if you find any.
2. Drive the vehicle onto the Lift. Try to center the vehicle's tires in the middle of each Runway.
Put the vehicle into park, engage the parking brake, put it in gear if it is a manual transmission, and chock the wheels.
3. Press and hold the Up button.
Both Runways start rising.
4. After the Runways pass one or two Safety Locks (you will hear them), release the Up button. The Runways stop rising.
5. Press and hold the pushbutton on the Pushbutton Air Valve, then press and hold the Lowering Handle.
The Runways start lowering.
6. When the Runways get to the ground, release the Lowering Handle.
7. Wait for one minute.

 **CAUTION** Always take a break between cycles. The Power Unit's motor is **not** constant duty; it cannot be run continuously.

8. Repeat the process, this time raising the Runways to a higher Safety Lock.
9. If the Lift is working without shaking, moving erratically, or squeaking, there is no need to repeat the procedure.

If the Lift is shaking, moving erratically, or squeaking (which is normal during the start-up period), repeat the procedure a couple more times, with at least a one-minute break between cycles.

If you continue to have issues, refer to **Troubleshooting** for assistance.

Final Checklist Before Operation

Make sure these things have been done **before** putting the Lift into service:

- Review the **Installation Checklist** to make sure all steps have been performed.
- Make sure the Power Unit is getting power from the power source.
- Check the Hydraulic Fluid reservoir on the Power Unit; it must be full of approved Hydraulic Fluid or automatic transmission fluid. **You can damage the motor by running it without enough fluid.**
- Check the Hydraulic System for leaks.
- Make sure all four Posts are properly anchored, shimmed, level, and stable.
- Make sure all Cables are properly seated in their Sheaves.
- Make sure all Safety Locks are operating normally.
- Make sure the backup Slack Safety Locks are **not** engaged.
- Make sure a copy of the *Installation and Operation Manual* is left with the Lift.
- If it has not been done already, perform an Operational Test of the Lift with a typical vehicle. Refer to **Performing an Operational Test**.

Operation

This section describes how to operate your Lift.

Safety Considerations

Do the following every time **before** you raise a vehicle on your Lift:

- **Check the Lift.** Walk all the way around the Lift, checking for any missing, heavily worn, or damaged parts. Do not operate the Lift if you find any issues; instead, take it out of service, then contact your dealer, email support@bendpak.com, or call **(800) 253-2363**.
- **Check the area.** Keep the area around and under the Lift clean and free of obstructions; anything that could cause a problem. Do not forget to check **above** the Lift. If you find an obstruction, move it out of the way. If you find any other issues, resolve them before using the Lift. Do not allow any people or animals within 30 feet of the Lift while it is in motion.
- **Check the operators.** Make sure everyone who is going to operate the Lift has been trained in its use, has read the labels on the unit, and has read the manual. Only the operator at the Controls should be within 30 feet of the Lift when it is in motion.

Do not allow children to operate the Lift. Do not allow anyone under the influence of drugs, alcohol, or medication to operate the Lift. Do not allow any unauthorized personnel to operate the Lift.

- **Check for safety.** Make sure everyone who is going to be walking near the Lift is aware of its presence and takes appropriate safety measures. Only put vehicles on the Runways.

When raising a vehicle, do not leave it until it is engaged on a Safety Lock. When lowering the Lift, do not leave it until it is on the ground.

- **Check the vehicle.** Never exceed the Lift's weight rating. Do not allow people inside a vehicle you are going to raise. Make sure the vehicle is not overbalanced on either end or either side.
- **NEVER** park any vehicle on the Lift's runways without placing two suitable wheel chocks behind each rear tire so that the vehicle cannot roll off the Lift. Vehicles parked on Lift **MUST** also be placed in Park or First Gear (Manual Transmission) with the Parking Brake fully applied.

 **WARNING:** Lift is slippery when icy or wet.

Using the Controls

The Controls for the Lift include:

- **Up button.** Press and hold to raise the Runways. Located near the top of the Power Unit.
To put Runways onto a Safety Lock position: Raise the Runways a little above where you want them, then press, and hold the Lowering Handle until the Runways lower onto the Safety Lock (do not press and hold the Pushbutton Air Valve). When the Runways stop moving down, they are engaged on a Safety Lock. *Before leaving the Lift, verify all four corners are engaged on their Safety Locks.*
- **Lowering Handle.** Press and hold to lower the Runways. Found in the middle of the Power Unit.
To lower raised Runways down to the ground: press and hold the pushbutton on the Pushbutton Air Valve first, then **press and hold** the Lowering Handle.

Watch the Runways as they lower to verify that they move evenly. If not, stop lowering the Lift and troubleshoot the problem.

⚠ WARNING: Never walk or work under the Lift until all four Safety Locks are securely engaged. If any of the Safety Locks cannot be engaged lower the Lift to the ground and arrange for repair.

⚠ WARNING: Never leave the Lift until all Safety Locks are securely engaged or it has been or it has been lowered to the ground.

- **Pushbutton Air Valve.** Press and hold the pushbutton on the Pushbutton Air Valve as part of the process to lower the Runways. Pressing and holding the Pushbutton Air Valve disengages the Safety Locks to lower the Runways.

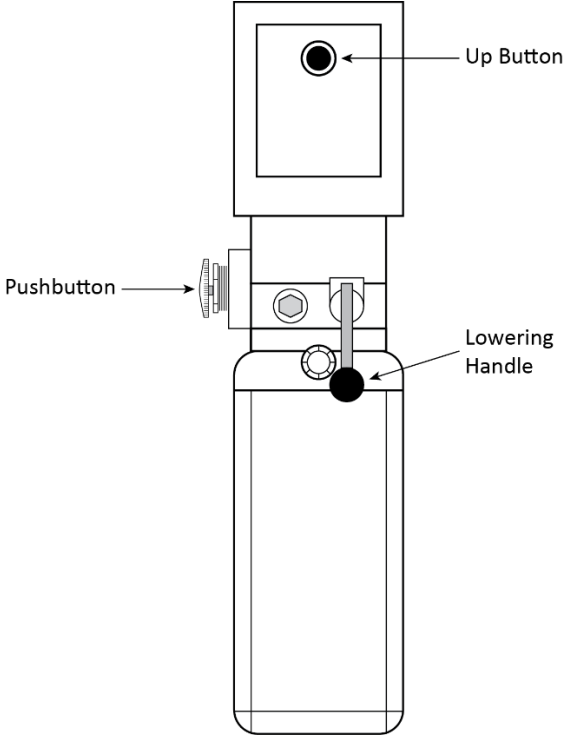
<p>To raise Runways to a Safety Lock:</p> <ol style="list-style-type: none">1. Press and hold Up Button.2. When just past desired height, release Up Button.3. Press and hold Lowering Handle.4. Runways stop going down when engaged on a Safety Lock; release Lowering Handle when they stop. <p><i>Do not press and hold Pushbutton.</i></p>	 <p>The diagram shows a vertical control panel. At the top is a rectangular box containing a circular 'Up Button'. Below this box is a 'Pushbutton' located on the left side. Further down is a 'Lowering Handle' which is a vertical rod with a circular grip at the bottom. Labels with arrows point to each of these three components.</p>	<p>To lower Runways:</p> <ol style="list-style-type: none">1. Press and hold Pushbutton.2. Press and hold Lowering Handle. Runways begin lowering.3. When Runways are fully lowered, release Pushbutton and Lowering Handle.4. Drive vehicle off Runways.
---	--	---

Raising and Lowering Vehicles

Keep the following in mind when operating your Lift:

- **Be safe.** Make sure to check for people, pets, and objects that might be in the path of the Lift as you raise or lower it. If there is something in the way, stop the Lift and move it out of the way. Watch the Lift carefully as it raises and lowers.

⚠ DANGER Pay careful attention when you are raising or lowering your Lift. If a person or pet is trapped under the Lift, they could be injured or, in rare cases, killed. If a problem arises, stop the Lift, and take action to make the Lift safe by lowering or raising to rest on a Safety Lock or on the ground.

- **The Power Disconnect Switch is there for a reason.** We hope you never have to use it, but if something unexpected happens, use the **Power Disconnect Switch** to immediately stop the Lift from moving.
- **Get what you need out of the vehicle before lifting it.** It is annoying to raise a vehicle and then realize you left something inside. **Never raise your Lift with people in the vehicle.**

-
- **Make sure the vehicle is balanced.** If there is extra weight on one end or the other, remove it or balance it before raising the vehicle.
 - **Center the vehicle's wheels on the Runway.** Centered wheels keep the vehicle balanced.

 **WARNING** **Chock Wheels** to reduce the risk of property damage, personal injury, or loss of life, **NEVER** park any vehicle on the Lift's runways without placing two suitable **Wheel Chocks** behind each rear tire so that the vehicle cannot roll backward from Lift. Vehicles parked on Lift **MUST** also be placed in Park or First Gear (Manual Transmission) with the Parking Brake fully applied.

To raise a vehicle:

1. Make sure the Runways are on the ground. If they are not, move them down to the ground.
2. Drive a vehicle onto the Runways.

Make sure all four wheels are fully on the Runways, as close to the center of the Runways as possible. Put the vehicle into park and put on the parking brake. If it is a manual transmission, make sure it is in a gear, not in neutral.

3. Press the **Up** button on the Power Unit.

The Runways begin to rise.

4. When the Runways get to the desired height, go up a little bit more, then release the **Up** button and press and hold the Lowering Handle.

The Runways engage on the most recently passed Safety Lock.

How do you know if one of the four Safety Locks has, for some reason, not engaged? If this happens, the non-engaged corner of the Lift will continue to go down, while the others stay where they are. This results in a Runway that is not flat. Always check to make sure that all four Safety Locks are engaged; you know they are if both Runways are completely flat.

 **WARNING:** Only leave your Lift either engaged on its Safety Locks or lowered to the ground.

5. With the Runways engaged on a Safety Lock, check around the vehicle to make sure everything looks good.

If you see anything wrong, fix it before anyone gets near the Runways or goes under them.

To lower a vehicle:

 **DANGER** **Crushing hazard and pinch points.** Do not place any part of your body between the top platform and any moving part of the Lift unless visual confirmation is made that the safety lock is fully engaged

1. Make sure there are no obstructions under the Runways you are about to lower.
If there are, move them out of the way before lowering the Runways.
2. Press and hold the pushbutton on the Pushbutton Air Valve, then press and hold the Lowering Handle.
The Runways start lowering.
3. When the Runways are fully lowered, release the pushbutton and the Lowering Handle.
4. Remove the tire chocks.
5. Drive the vehicle off the Runways, if safe.

Maintenance

 **DANGER** Before performing any maintenance on this Lift, make sure it is completely disconnected from power. If your organization has Lockout/Tagout procedures implement them before beginning any maintenance work.

 **DANGER** **Crushing hazard and pinch points.** Do not place any part of your body between the top deck and any moving part of the Lift unless visual confirmation is made that the safety lock is fully engaged, and that the Lift's downward motion is blocked by a Jack Stand, Forklift or other Load-Holding device that will prevent the Lift's downward movement while working under it.

Important: Unless stated otherwise, all Lift maintenance may be carried out by the owner/employee and does not require trained Lift personnel.

To maintain your Lift:

- **Daily:** Keep the Lift clean. Wipe up any spills, remove water, ice and clean and dirt from the Lift

 **WARNING:** Work with care. The Lift is slippery when wet or icy.

- **Daily:** Make a visual inspection of all moving parts and check for damage or excessive wear. Replace any damaged or worn parts before using the Lift.

 **DANGER** Do not use the Lift if the Cables are damaged or extremely worn. If a vehicle is raised when you notice the damage or extreme wear, very carefully lower the vehicle to the ground. When the Lift is on the ground, take it out of service, disconnect it from power, and make arrangements to fix the damage or wear.

- **Daily:** Make sure all Safety Locks are in good operating condition. Do not use your Lift if the Safety Locks are damaged or excessively worn.
- **Daily:** Remove the Slip Plate and clean around the ball casters with a brush or rag to remove debris and then lubricate the Ball Casters with a light coat of white lithium grease.
- **Monthly:** Check all labels on the Lift. Replace them if they are illegible or missing.
- **Monthly:** Refer to **Lubricating the Lift**. Use white lithium grease or similar to lubricate the inside of the Lift Posts where the slide blocks on the Crosstubes travel.
- **Monthly:** Check Hydraulic Fluid levels. Refill if low.
- **Monthly:** Lubricate the wire rope (Cables). Use a wire-rope lubricant such as 90-WT gear oil or ALMASOL® Wire Rope Lubricant.
- **Monthly:** Check cable connections, bolts, and pins for proper mounting and torque.
- **Every two months:** Check all Anchor Bolts to make sure they are properly torqued. If they are loose, tighten them.
- **Every three months:** Refer to **Lubricating the Lift**. Remove the Sheave Pins and lubricate the pins and bearings with red lithium grease.
- **As required.** Take the Lift out of service and then replace the Cables if there are signs of damage or extreme wear.

 **WARNING:** Do not operate your Lift if you find maintenance issues; instead, take the Lift out of service, then contact your dealer, visit [bendpak.com/support](https://www.bendpak.com/support), email support@bendpak.com, or call **(800) 253-2363**.

Lift and Hydraulic Fluid Disposal - End of Service Life

Once your Lift has reached the end of its service life it must be disposed of properly. Metal recyclers will be able to advise on methods and costs to remove the Lift and will *reuse* the materials, diverting them from landfills. The best option is to contact a metal recycling center and discuss the size and weight of the Lift to determine if the facility can deconstruct and recover the usable components and metals.

The Hydraulic Cylinders, Hoses, Fittings, and the Power Unit itself must be disposed of in accordance with current national, state, and local regulations governing the use and disposal of hazardous materials. These components and any used Hydraulic Fluid **must not** be disposed of by dropping it into the trash or dumping it into the street. The Hydraulic Fluid contains toxic ingredients that are harmful to the environment.

These components and the Hydraulic Fluid are required to be recycled or must be delivered to a hazardous waste collection facility.

If you have large amounts of Hydraulic Fluid, consider contacting a commercial waste disposal company. In all cases, the best approach is to find an appropriate facility and contact them — in advance — to ask them: what kinds of fluids and materials they accept, what kind of containers it must be in, what hours they are open, their location, and any other information specific to their facility.

If you are unable to find an appropriate facility, the website [earth911.com](https://www.earth911.com) has resources that may be of help.

Wire Rope Inspection and Maintenance

Your Lift's Cables, which are wire rope, should be inspected regularly:

- Wire rope should be replaced when there are visible signs of damage or extreme wear. *Do not use the Lift if it has damaged or worn Cables; **take it out of service!***

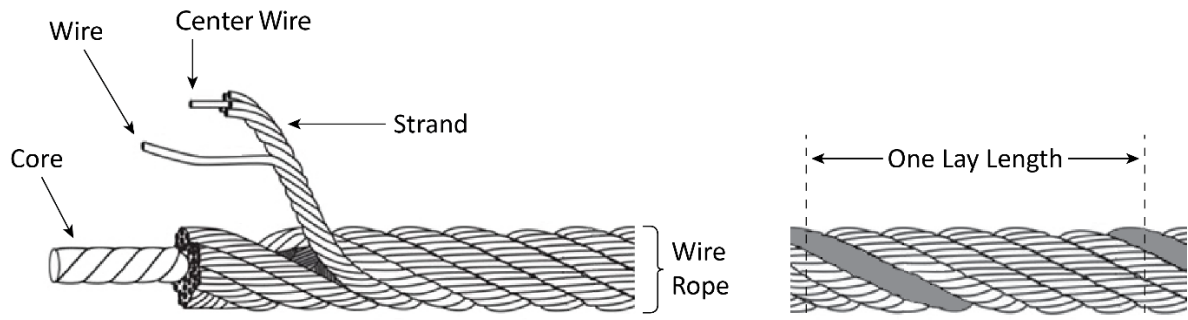

- Wire rope should be always maintained in a well-lubricated condition.

Wire rope is only fully protected when each wire strand is lubricated both internally and externally. Excessive wear shortens the life of wire rope. Use a wire-rope lubricant that penetrates to the core of the rope and provides long-term lubrication between each individual strand, such as 90-WT gear oil or ALMASOL® Wire Rope Lubricant. To make sure that the inner layers of the rope remain well lubricated, lubrication should be done at least every three months during normal operation.

- All Sheaves and guide rollers that contact moving wire rope should be given regular visual checks for surface wear and lubricated to make sure they run freely. This should be done every three months during normal operation.

For all sheave axles, use standard wheel bearing grease. For all Sheaves and/or guide rollers, use 90-WT gear oil or a similar heavy lubricant, applied by any method including pump/spray dispensing, brush, hand, or swabbing.

- How often should you inspect?

Wire rope should be visually inspected at least once each day when in use, as suggested by American Petroleum Institute's Recommended Practice 54 guidelines. Any wire rope that meets the criteria for removal must be immediately replaced.

- When should you replace wire rope due to broken wires?

Wire rope should be removed from service if you see six randomly distributed broken wires within any one lay length or three broken wires in one strand within one lay length.

- Are there other reasons to replace your wire rope?

Yes, corrosion that pits the wires and/or connectors, evidence of kinking, crushing, cutting, bird-caging, or a popped core, wear that exceeds 10% of a wire's original diameter, or heat damage.

- How do you find broken wires?

- a. Relax your rope to a stationary position and move the pick-up points off the Sheaves. Clean the surface of the rope with a cloth — a wire brush, if necessary — so you can see any breaks.
- b. Flex the rope to expose any broken wires hidden in the valleys between the strands.
- c. Visually check for any broken wires. One way to check for crown breaks is to run a cloth along the rope to check for possible snags.
- d. With an awl, probe between wires and strands and raise any wires that appear loose.

Torque Chart

FASTENER TORQUE CHART														
Bolt Size (SAE)	Bolt Grade (SAE)	SAE Grade 0-1-2	SAE Grade 5	SAE Grade 8	Socket Head Cap Screw SAE Grade	Bolt Size (Metric)	Metric Class 4.6	Metric Class 8.8	Metric Class 10.9	Metric Class 12.9	Tightening Torque			
											Lubricated (ft-lbs)	Zinc Plated (ft-lbs)	Plain & Dry (ft-lbs)	
1/4-20	M6 x1.0	2.3	2.6	3.0	5.8	6.6	7.7	8.3	9.4	11.0	13.0			
5/16-18	M8 x 1.25	3.8	4.3	5.0	9.7	11.0	13.0	13.9	15.8	18.4	21.7			
3/8-16	M10 x 1.50	10.8	12.3	14.4	27.9	31.6	37.2	39.9	45.2	52.9	62.2			
7/16-14	N/A	24.0	27	30.0	35.0	42	50.0	55.0	59	68	76.0			
1/2-13	M12 x 1.75	18.9	21.4	25.2	48.7	55.1	64.9	69.6	78.9	92.8	108.5			
9/16-12	M14 x 2.00	30.2	34.2	40.2	77.8	88.1	103.7	111.3	126.1	148.4	173.4			
5/8-11	M16 x 2.00	47	53	62	121	137	161	173	196	230	269			
3/4-10	M18 x 2.50	65	73	86	167	189	222	239	270	318	372			
7/8-9	M22 x 2.50	136	155	182	320	365	430	460	515	600	640			

WARNING! Prior to installation, inspect all accompanying manuals, parts lists and catalogs to ensure you have all the necessary parts. Identify all fasteners and their proper torque settings as illustrated on this chart. Proper torquing practices cannot be over emphasized. Torque values are provided as a convenient method of achieving correct pre-loading of highly stressed fasteners. If the fasteners are not properly plated, the fastener threads are not clean and free of deformation, or are not properly lubricated, the correct fastener pre-load will not be achieved even though the given torque value is reached. For this reason, it is critical that all fasteners be inspected for proper plating, thread form and correctly lubricated prior to torquing. Failure to verify a fastener's serviceability or to correctly lubricate the fastener prior to assembly and torquing will result in the fastener not being properly pre-loaded and subsequent failure of the fastener may occur. The torque values can only be achieved if the nut (or tapped hole) has a proof load greater than or equal to the bolt's minimum ultimate tensile strength. Clamp loads estimated as 75% of proof load for specified bolts. Torque values are listed in foot-pounds. Torque wrenches should be calibrated on an annual basis. Never use an impact driver on a torque multiplier.

Troubleshooting

This section describes how to troubleshoot your Lift.

Note: If your Lift is not functioning correctly, you must take it out of service until it is fixed.

Important: Unless stated otherwise, all Lift maintenance may be carried out by the owner/employee and does not require trained Lift personnel.

Runways do not raise or do not lower, once raised.	<p>Make sure there is sufficient Hydraulic Fluid in the reservoir.</p> <p>Make sure there is no air in the Hydraulic System.</p> <p>Make sure none of the Hydraulic Hoses are pinched or leaking.</p> <p>Make sure the Power Unit is getting power.</p> <p>If the Hydraulic Fluid is dirty, replace it with clean fluid.</p> <p>Make sure Lift is not overloaded.</p>
Runways do not lower past the nearest Safety Lock even when pressing and holding the pushbutton.	Problem with the Air Lines; check to make sure all sections of the Air Line are connected and not leaking.
One corner of the Lift is lower than the other three corners.	The Safety Lock on the lower corner is not engaged. Raise the Runways up, then lower them down onto the Safety Locks. Check to make sure all four Safety Locks are engaged.
Runways move erratically or squeak when in use.	Move the Runways up and down a few times to flush any residual air from the Hydraulic System. Make sure to pause for at least 2 minutes between cycles.
Runways do not stay up.	<p>Check for leaking Hydraulic Fluid.</p> <p>Make sure the Runways are left on their Safety Locks.</p>
Motor not running.	<p>Check the connection to the power source; make sure it is plugged in and of the appropriate voltage.</p> <p>Check the wiring diagram.</p>
Hydraulic Fluid is dirty.	Replace the dirty fluid with clean, approved Hydraulic Fluids, such as Dexron III, Dexron VI, Mercon V, Mercon LV, Shell Tellus S4 / S3 / S2, or comparable.
Runways make odd noises.	Lubricate the bushings on the sheaves on the sides of the Crosstubes using white lithium grease. If the Lift is new, a break-in period may be needed; run the Lift several times each day. If the noises persist, contact BendPak Support.

If you continue to have issues with your Lift, take it out of service, then contact your dealer, go to bendpak.com/support, email support@bendpak.com, or call **(800) 253-2363** select option 7, then 4.

Wiring Diagrams

Power Unit 5585785

208–230 VAC 1Ph., 50/60Hz., 2HP

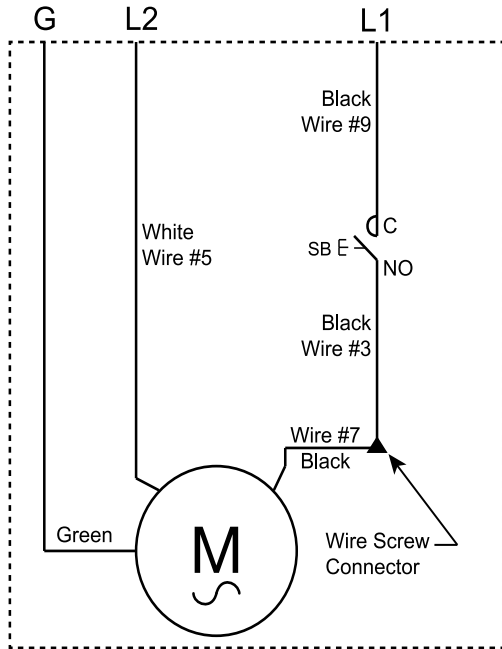

Power Unit 5585285

208–240 VAC, 1Ph, 50/60Hz., 3HP

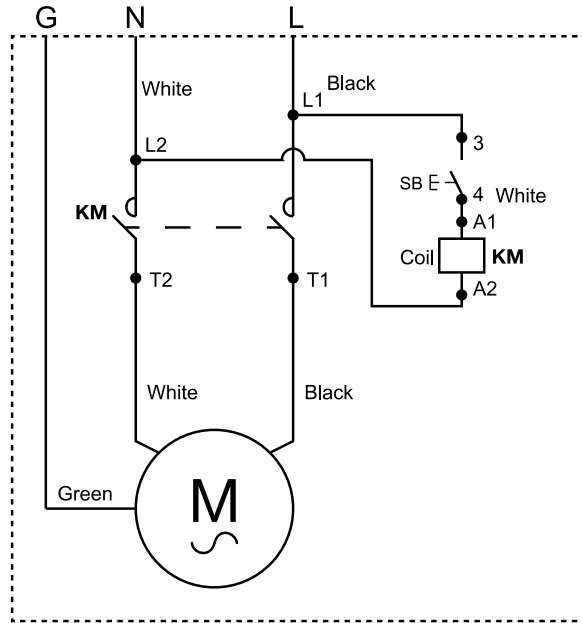

Power Unit 5585175

2HP, 1Ph., 50-60Hz.
220 VAC @ 50HZ.
208-230 VAC @ 60Hz.

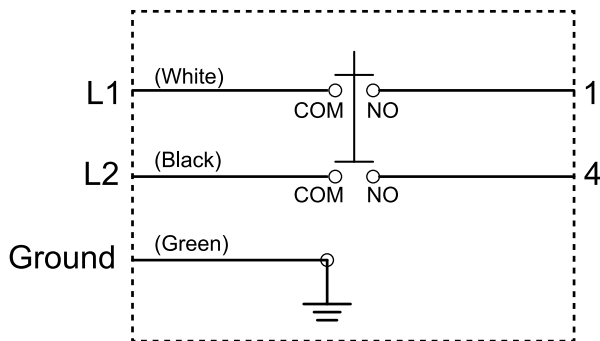

Labels

A



B

⚠ DANGER

VISUALLY CONFIRM THAT ALL PRIMARY SAFETY LOCKS ARE ENGAGED BEFORE ENTERING WORK AREA.

Suspension components on this lift are intended to raise and lower lift; they are NOT load-holding devices. Do not go under an elevated lift until visual confirmation is made that the lift is engaged on its Safety Locks. Refer to the manual for proper Safety Lock procedures and additional instructions.

VÉRIFIER VISUELLEMENT QUE TOUS LES VEROUS DE SÉCURITÉ PRIMAIRES SONT ENGAGÉS AVANT D'ENTRER DANS LA ZONE DE TRAVAIL.

Les composants de suspension de cet élévateur sont destinés à élever et abaisser l'ascenseur, ce ne sont PAS des dispositifs de maintien de la charge. Ne passez pas sous un ascenseur surélevé avant d'avoir obtenu la confirmation visuelle que l'ascenseur est engagé sur ses serrures de sécurité. Reportez-vous au manuel pour connaître les procédures de verrouillage de sécurité et les instructions supplémentaires.

⚠ WARNING

Wire Rope Inspection and Maintenance

- Replace lifting cables if worn or damaged or when an excessive broken strand, kink, deformation, or area of fraying occurs.
- Keep wire rope in a well-lubricated condition at all times. Wire rope is only fully protected when each wire rope is lubricated both internally and externally. Excessive wear shortens the life of wire rope. Use wire rope lubri-kart that penetrates to the core of the rope and provides long-term lubrication between individual strands. Lubrication should be done at least every three months during normal operation.
- All sheaves and guide rollers in contact with the moving wire rope should be given regular visual checks for surface wear and lubricated to make sure they run freely. This should be done at least every three months during normal operation. For sheave rolls, use shearless wheel-bearing grease. For all sheaves and/or guide rollers, use 90-WT gear oil or similar heavy lubricant applied by any method including purging, dispensing, brush, hand, and/or spraying.

Failure to read, understand, and follow these instructions may cause death or serious injury. Read and understand these instructions before using lift.

⚠ ATTENTION

Inspection et maintenance des câbles

- Remplacez les câbles de levage si l'un ou des dommages sont détectés, tels que des brins cassés, des fentes, des déformations ou des zones de forte abrasion excessive.
- Gardez le câble lubrifié tout le temps. Le câble métallique n'est entièrement protégé que lorsque chaque brin est lubrifié, à la fois à l'intérieur et à l'extérieur. Une usure excessive raccourcit la durée de vie du câble. Utilisez un lubrifiant pour câbles métalliques qui pénètre dans le noyau du câble et assure une lubrification à long terme entre les brins. La lubrification doit être effectuée au moins tous les trois mois en fonctionnement normal.
- Toutes les poulies et les points de guidage en contact avec le câble métallique en mouvement doivent être inspectés à des intervalles réguliers de l'usure de la surface et lubrifiés pour assurer un fonctionnement fluide. Cela doit être fait au moins tous les trois mois pendant le fonctionnement normal. Pour les rouleaux à roulement, utilisez de la graisse sans plomb pour roulement de roue. Pour toutes les poulies et/ou les points de guidage, utilisez de l'huile pour engrenages 90-WT ou un lubrifiant lourd similaire appliqué selon la méthode que vous préférez : pulvérisation, brossage, main, et/ou pulvérisation.

Lisez et comprenez ces instructions avant d'utiliser l'ascenseur. Ne pas lire, comprendre et suivre ces instructions peut provoquer des blessures graves, voire mortelles.

IMPORTANT OPERATION / MAINTENANCE INSTRUCTIONS - PLEASE READ

TO RAISE LIFT

- ✓ Position vehicle on all four corners of lift platform.
- ✓ Set parking brake or use wheel chock to hold vehicle in position.
- ✓ Release parking brake, be sure all personnel are clear of lift and surrounding area. (No special attention is needed for this step.)
- ✓ Raise lift to desired height by pressing up/down on power unit.
- ✓ When near correct height release and re-engage lift at three-inch rising lift.
- ✓ Stop immediately if car shifts or becomes unlevel.
- ✓ After vehicle is raised to desired height, lower lift into the raised Safety Lock. Do not allow vehicle to become unlevelly lock.
- ✓ Always make sure all Primary Safety Locks are engaged before entering work area.

TO LOWER LIFT

- ✓ Make sure all personnel, tools, and equipment are clear of lift and surrounding area.
- ✓ Operate lift to lower position on power unit. Lower lift at least one inch to allow adequate clearance for locks to close.
- ✓ Press and hold the lower button for three seconds.
- ✓ Lower vehicle by slow pressing and holding lowering handle.
- ✓ When lowering lift, make sure that all personnel and objects are kept clear.
- ✓ Always wear or use seat belt or safety harness while lowering.
- ✓ Always make sure safety locks are disengaged. If one of the locks malfunctions, engage on descent. Lift vehicle within any capacity, personal injury or death.

REQUIRED MONTHLY MAINTENANCE

- ✓ Operate operation manual for factory recommended frequencies.
- ✓ Adjust lift cables to ensure lift raises level and Safety Locks engage automatically.
- ✓ Check all drive shaft connections, ball joints, and tires for correct proper wear/alignment.
- ✓ Visually inspect Safety Locks for proper operation.
- ✓ Visually inspect concrete. Do not use lift if concrete shows signs of cracking or other deterioration.
- ✓ Inspect all brake and other fluids, replace as necessary.
- ✓ Check to make the operation and descent.
- ✓ Inspect all bolts and other fasteners to make sure they are properly secured.
- ✓ Make a visual inspection of all moving parts and check for signs of excessive wear.
- ✓ Inspect all body parts before lift is put back into operation.

⚠ WARNING

- Warning! Do not touch any moving parts of the lift in operation. Do not touch lift if not completely stopped.
- Always operate lift with people or equipment inside.
- Always respect rated capacity.
- Always respect Safety Locks and engage before entering work area.
- Always respect lift descent safety engaged on Safety Locks.
- Always respect the descent order by get well below damage caused by descent and covered by the warranty.

⚠ ATTENTION

- Attention! Ne touchez pas les pièces mobiles de l'ascenseur en fonctionnement.
- Ne touchez pas l'ascenseur si celui-ci n'est pas complètement arrêté.
- Ne touchez pas l'ascenseur avec des personnes ou des équipements à l'intérieur.
- Respectez toujours la capacité nominale.
- Respectez toujours les verrous de sécurité et engagez-les avant d'entrer dans la zone de travail.
- Respectez toujours l'ordre de descente en engageant les verrous de sécurité.
- Respectez toujours l'ordre de descente en descendant et en étant protégé par la garantie.

C

<div style="background-color: yellow; padding: 5px;">⚠ CAUTION</div> <p style="text-align: center;">Lift to be used by trained operator ONLY.</p>	<div style="background-color: yellow; padding: 5px;">⚠ CAUTION</div> <p style="text-align: center;">Authorized personnel only in lift area.</p>
<p>The messages and pictographs shown are generic in nature and are meant to generally represent hazards common to all automotive lifts regardless of specific style.</p> <p>Funding for the development and validation of these labels was provided by the Automotive Lift Institute, PO Box 85 Cortland, NY 13045.</p> <p>Replacement label sets may be obtained from the original lift manufacturer and ALI's member companies. They are protected by copyright.</p> <p>www.autlift.org © 2012 by ALI, Inc. ALI/PA/2012</p>	
<div style="background-color: red; color: white; padding: 2px;">⚠ WARNING</div> <p style="text-align: center;">Clear area if vehicle is in danger of falling.</p>	<div style="background-color: red; color: white; padding: 2px;">⚠ WARNING</div> <p style="text-align: center;">Remain clear of lift when raising or lowering vehicle.</p>
<div style="background-color: red; color: white; padding: 2px;">⚠ WARNING</div> <p style="text-align: center;">Keep clear of pinch points when lift is moving.</p>	<div style="background-color: red; color: white; padding: 2px;">⚠ WARNING</div> <p style="text-align: center;">Keep feet clear of lift while lowering.</p>
<div style="background-color: red; color: white; padding: 2px;">⚠ WARNING</div> <p style="text-align: center;">Do not override self-closing lift controls.</p>	<div style="background-color: red; color: white; padding: 2px;">⚠ WARNING</div> <p style="text-align: center;">Chock wheel to prevent vehicle movement.</p>
<p>The messages and pictographs shown are generic in nature and are meant to generally represent hazards common to all automotive lifts regardless of specific style.</p> <p>Funding for the development and validation of these labels was provided by the Automotive Lift Institute, PO Box 85 Cortland, NY 13045.</p> <p>Replacement label sets may be obtained from the original lift manufacturer and ALI's member companies. They are protected by copyright.</p> <p>www.autlift.org © 2012 by ALI, Inc. ALI/PA/2012</p>	
<div style="background-color: blue; color: white; padding: 5px;">NOTICE</div> <p style="text-align: center;">Read operating and safety manuals before using lift.</p>	<div style="background-color: blue; color: white; padding: 5px;">NOTICE</div> <p style="text-align: center;">Proper maintenance and inspection is necessary for safe operation.</p>
<p>The messages and pictographs shown are generic in nature and are meant to generally represent hazards common to all automotive lifts regardless of specific style.</p> <p>Funding for the development and validation of these labels was provided by the Automotive Lift Institute, PO Box 85 Cortland, NY 13045.</p> <p>Replacement label sets may be obtained from the original lift manufacturer and ALI's member companies. They are protected by copyright.</p> <p>www.autlift.org © 2012 by ALI, Inc. ALI/PA/2012</p>	
<div style="background-color: red; color: white; padding: 5px;">⚠ NOTICE</div> <p style="text-align: center;">Do not operate a damaged lift.</p>	

HDS-14LSX / HDS-14LSXE Lifts

78

P/N 5900162 — March 2024 — Rev. F7

D

⚠ DANGER

THE MAXIMUM LIFTING CAPACITY FOR THIS LIFT IS DESCRIBED BELOW

Maximum Lifting Capacity
14,000 lbs. / 6,350 kg
Max. Lifting Cap. / Front of Lift Center
7,000 lbs. / 3,175 kg
Max. Lifting Cap. / Rear of Lift Center
7,000 lbs. / 3,175 kg

Exceeding the weight capacity of this lift can damage lift and/or property and may cause personal harm, injury or death to operators and/or bystanders. All vehicles **MUST** be positioned on lift with **CENTER OF GRAVITY** midway between adapters and/or centered on runways. Damage to lift due to overloading or misuse **IS NOT** covered under warranty.

LA CAPACITÉ DE LEVAGE MAXIMUM POUR CE LEVAGE EST DÉCRIT CI-DESSOUS

Capacité de Levage Maximale
14,000 lbs. / 6,350 kg
Max. Capuchon De Levage. / Avant du centre de relevement
7,000 lbs. / 3,175 kg
Max. Capuchon De Levage. / Arrière du centre de levage
7,000 lbs. / 3,175 kg

Le dépassement de la capacité de poids de cet élévateur peut endommager l'ascenseur et / ou les biens et peut causer des dommages corporels, des blessures voire la mort aux opérateurs et / ou aux passants. Tous les véhicules **DOIVENT** être placés sur l'élévateur avec le **CENTRE DE GRAVITÉ** à mi-chemin entre les adaptateurs et / ou au centre des pistes. Dommages à soulever dus à la surcharge ou une mauvaise utilisation **N'EST PAS** couverte par la garantie.

PN 5905654

H

⚠ WARNING

SLIPPERY WHEN WET OR ICY

Use caution when driving onto wet or icy drive-up ramps and platforms. **DO NOT** walk on lift surfaces that are wet or icy.

⚠ AVERTISSEMENT

GLISSANT LORSQU'IL EST MOUILLÉ OU GLACÉ

Soyez prudent lorsque vous conduisez sur des rampes d'accès mouillées ou verglacées et les plateformes. **NE PAS** marcher sur des surfaces de levage humides ou glacées.

PN 5905138

I

CERTIFIED AUTOMOTIVE LIFT

ALI CERTIFIED
To the provisions of ANSI/ALI LCTV-2017 SAFETY REQUIREMENTS FOR CONSTRUCTION, TESTING AND VALIDATION

Automotive Lift Institute, Inc. | Corland, NY 13045

MET LISTED
Conforms to ANSI/DUL 201 SAFETY STANDARD FOR GARAGE EQUIPMENT

CERTIFIED
To CAN/CSA C22.2 NO.68 MOTOR OPERATED APPLIANCES (HOUSEHOLD & COMMERCIAL)

ALI Lubricants, Inc. | DAYTON, OH 45424

Certification Label Serial Number: AL00617000M

PN 5905654

E

⚠ ATTENTION ⚠

MAXIMUM LIFTING CAPACITY
CAPACITÉ DE LEVAGE MAXIMUM

14000 Lbs.
6350 Kg.

PN 5905654

F

BP BendPak

1645 Lemenwood Dr.
Santa Paula, CA USA
www.BendPak.com

LIFT TYPE: Surface Mount **MANUFACTURER:** BendPak. See data plate for product details
POWER: Electric/Hydraulic **INSTALLATION:** See manual or contact factory

Safety Instructions: If attachments, accessories, or configuration-modifying components that are located in the load path affect operation of the lift, affect the lift electrical listing, or affect intended vehicle accommodation are used on this lift and, if they are not certified for use on this lift, then the certification of this lift shall become null and void. Contact the participant for information pertaining to certified attachments, accessories, or configuration-modifying components.

BendPak lifts are supplied with concrete fasteners meeting the criteria as prescribed by ASTM E488/ E488M-18. Lift buyers are responsible for any special regional, structural, and/or seismic anchoring requirements specified by any other agencies and/or codes such as the Uniform Building Code (UBC) and/or International Building Code (IBC).

The manufacture, use, sale, or import of this product may be subject to one or more United States

PN 5905940

L

AMERICAN OWNED

EST. 1965

50+ YEARS

BENDPAK INC.

PN 5906044

G

NOTICE

If attachments, accessories, or configuration modifying components used on this lift are located in the load path and affect operation of the lift, affect the lift electrical listing, or affect intended vehicle accommodation; and if they are not certified for use on this lift, then the certification of this lift shall become null and void. Contact the participant for information pertaining to certified attachments, accessories, or configuration modifying components.

www.autolift.org ©2011 by ALI, Inc. ALI / WLSIA01

PN 5905377

M

CALIFORNIA PROPOSITION 65

⚠ WARNING ⚠

WARNING! This product can expose you to chemicals including styrene and vinyl chloride which are on the list of over 900 chemicals identified by the State of California to cause cancer, birth defects or reproductive harm. ALWAYS use this product in accordance with the manufacturer's instructions. For more information, go to www.p65warnings.ca.gov.

PN 5905775

PN 5905775

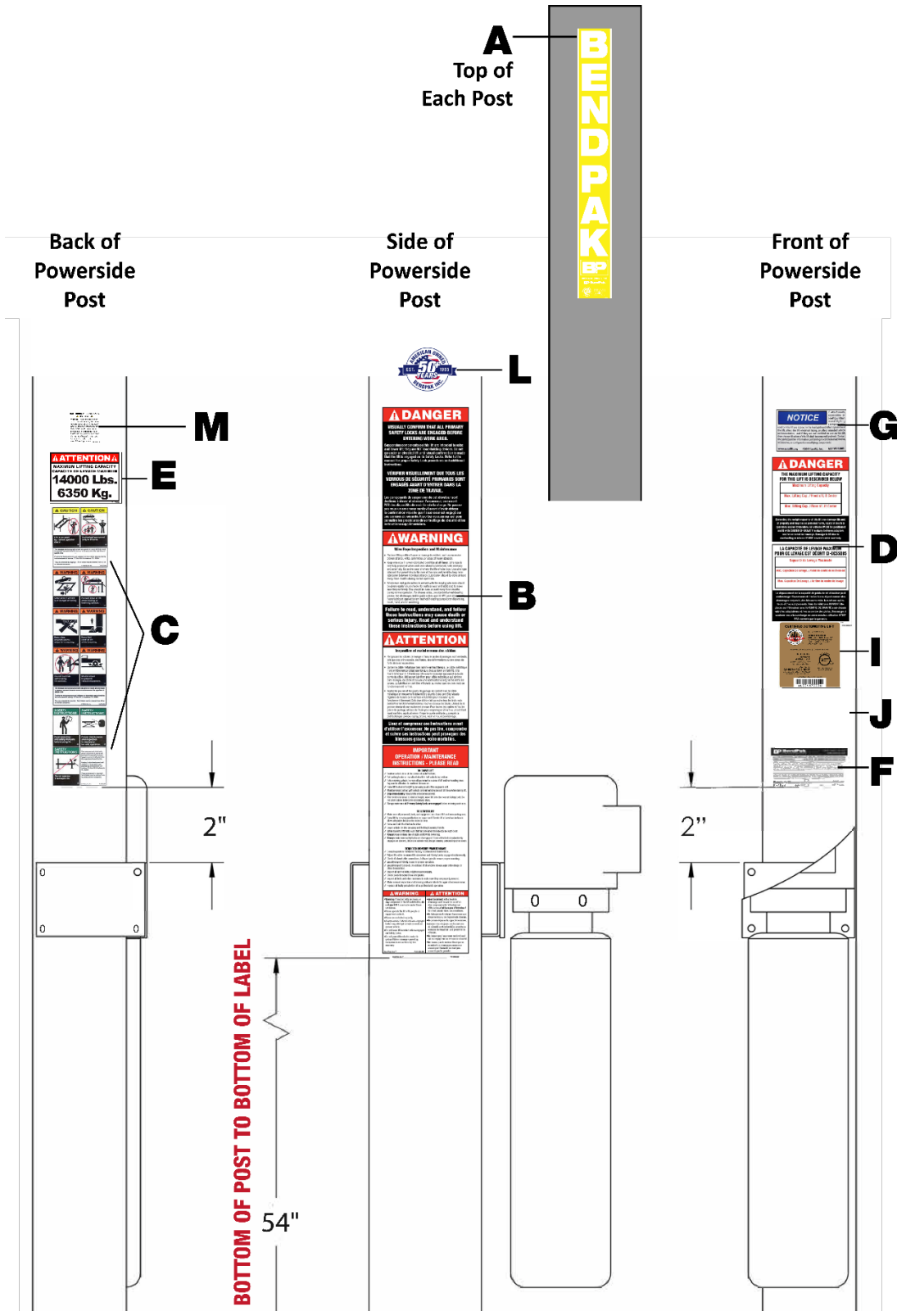

Parts Drawings

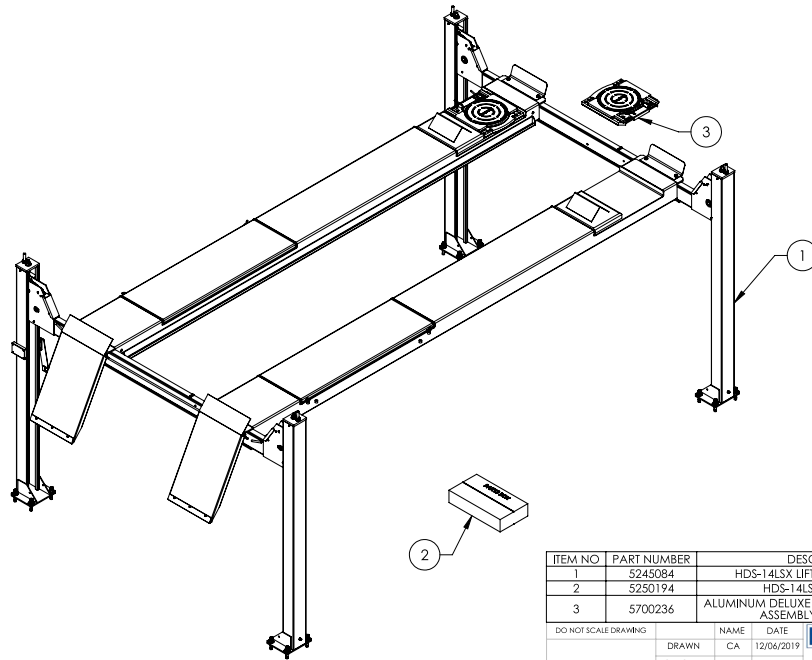

ITEM NO	PART NUMBER	DESCRIPTION	QTY	REV
1	5245084	HDS-14LSX LIFT SUPERSTRUCTURE	1	J
2	5250194	HDS-14LSX PARTS BOX	1	N
3	5700236	ALUMINUM DELUXE ALIGNMENT TURNPLATE ASSEMBLY, SET OF TWO	1	-

DO NOT SCALE DRAWING	NAME	DATE	 1445 LEMONWOOD DR. SANTA PAULA, CA 93060
	DRAWN	CA 12/06/2019	
DIMENSIONS ARE IN MM 	CHECKED	CA	TITLE: HDS-14LSX PRODUCTION LIFT VER D (CE CERT)
	THIRD ANGLE PROJECTION		
<small> PROPRIETARY AND CONFIDENTIAL THE INFORMATION CONTAINED IN THIS DRAWING IS THE SOLE PROPERTY OF BENDPAK INC. AND IS TO BE USED FOR THE MANUFACTURE OF THE SPECIFIC PARTS OF A MACHINE THE UNAUTHORIZED REPRODUCTION OF THIS DRAWING IS PROHIBITED. </small>			SCALE: 1:35 SHEET 1 OF 3

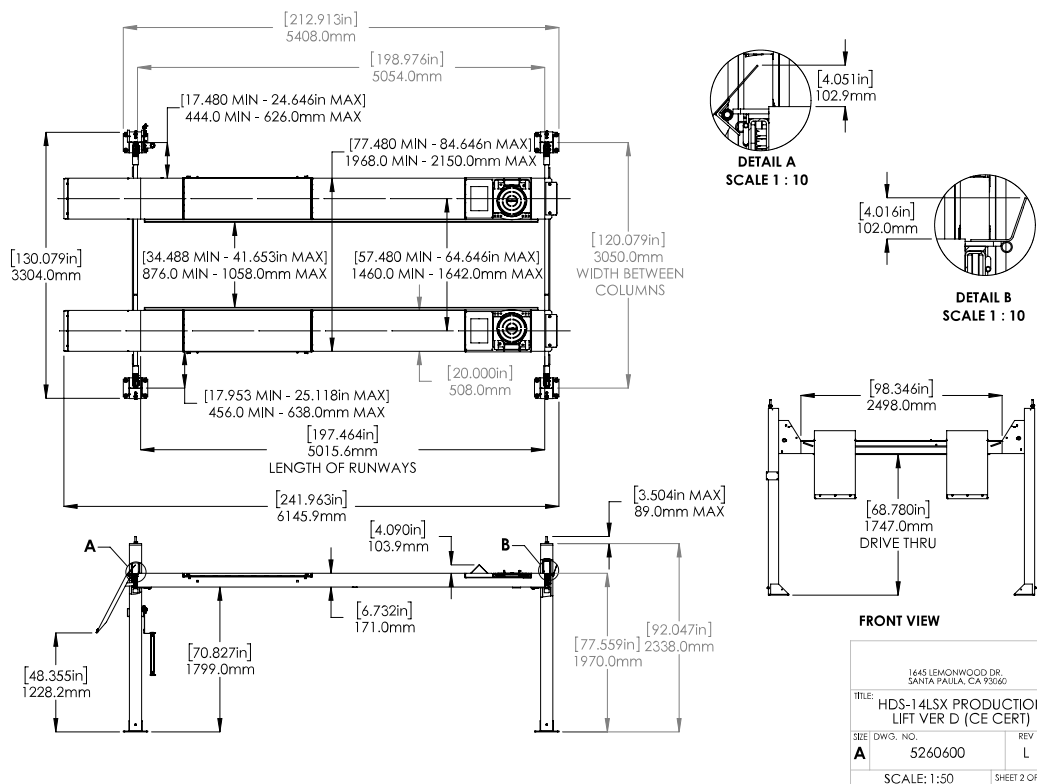

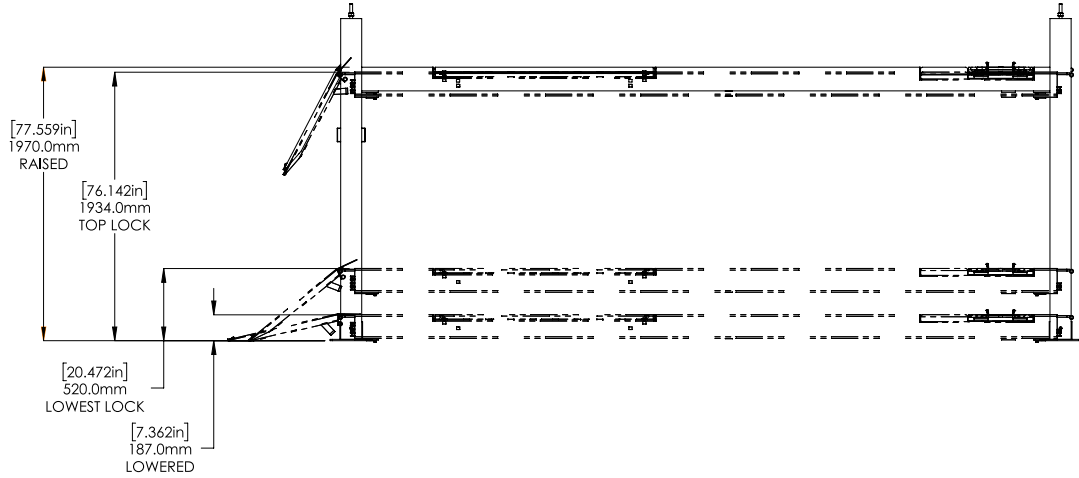

1. DIMENSIONS SHOWN ARE WITH THE LOCK LADDERS ADJUSTED ALL THE WAY UP

BP BendPak.
 1645 LEMONWOOD DR.
 SANTA PAULA, CA 93060

TITLE: HDS-14LSX PRODUCTION LIFT VER D (CE CERT)

SIZE: DWG. NO. 5260600 REV L

SCALE: 1:30 SHEET 3 OF 3

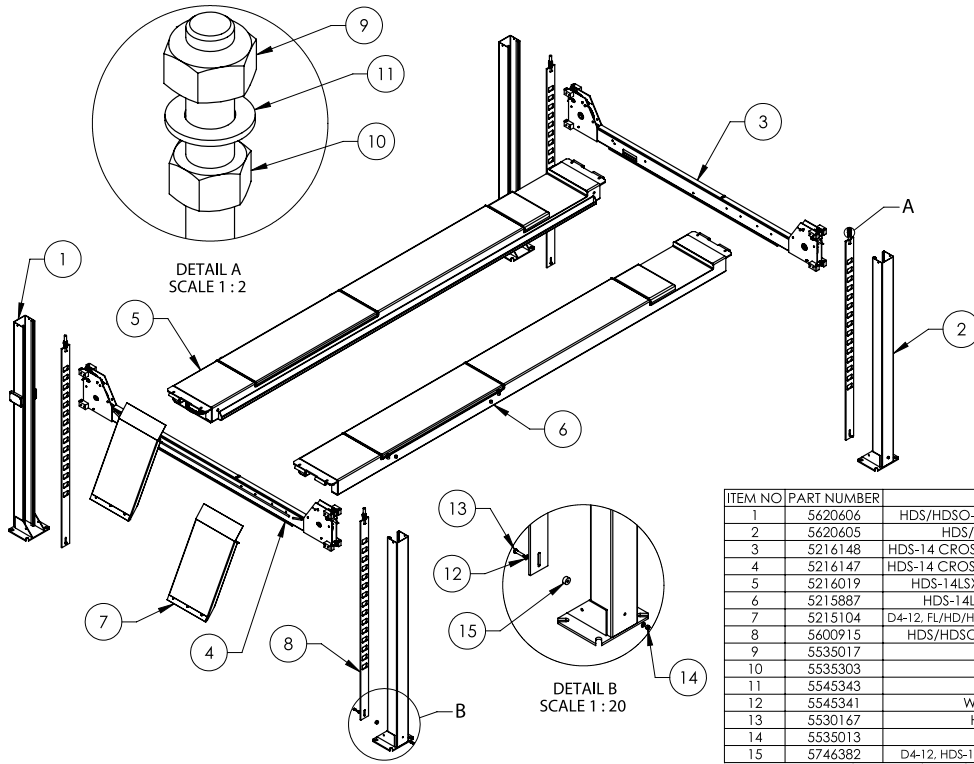

WHERE USED
HDS-14LSX

ITEM NO	PART NUMBER	DESCRIPTION	QTY	REV
1	5620606	HDS/HDSO-14 POWER SIDE POST WELDMENT	1	C
2	5620605	HDS/HDSO-14 POST WELDMENT	3	C
3	5216148	HDS-14 CROSSTUBE ASSEMBLY, SMALL WINDOW	1	A
4	5216147	HDS-14 CROSSTUBE ASSEMBLY, LARGE WINDOW	1	A
5	5216019	HDS-14LSX POWER SIDE RAMP ASSEMBLY	1	B
6	5215887	HDS-14LSX OFF SIDE RAMP ASSEMBLY	1	B
7	5215104	D4-12, FL/HD/HDS/HDSO-14 DRIVE UP RAMP ASSEMBLY	2	K
8	5600915	HDS/HDSO-14 SAFETY LADDER WELDMENT	4	B
9	5535017	NUT M20 x 2.5 NL	4	-
10	5535303	NUT M20 x 2.5	4	-
11	5545343	WASHER, M20 FLAT	4	-
12	5545341	WASHER M10 x Ø20 FLAT	8	-
13	5530167	HHB M10 x 1.5 x 45mm	4	-
14	5535013	NUT M10 x 1.5 NL	4	-
15	5746382	D4-12, HDS-14 SPACER, SAFETY LADDER, 15mm LG	4	A

DO NOT SCALE DRAWING

DRAWN: CA DATE: 12/06/2019

CHECKED:

DIMENSIONS ARE IN MM

THIRD ANGLE PROJECTION

PROPRIETARY AND CONFIDENTIAL
 THE INFORMATION CONTAINED IN THIS DRAWING IS THE SOLE PROPERTY OF BENDPAK INC. ANY REPRODUCTION IN PART OR AS A WHOLE WITHOUT THE WRITTEN PERMISSION OF BENDPAK INC. IS PROHIBITED.

BP BendPak.
 1645 LEMONWOOD DR.
 SANTA PAULA, CA 93060

TITLE: HDS-14LSX LIFT SUPERSTRUCTURE

SIZE: DWG. NO. 5245084 REV J

SCALE: 1:45 SHEET 1 OF 1

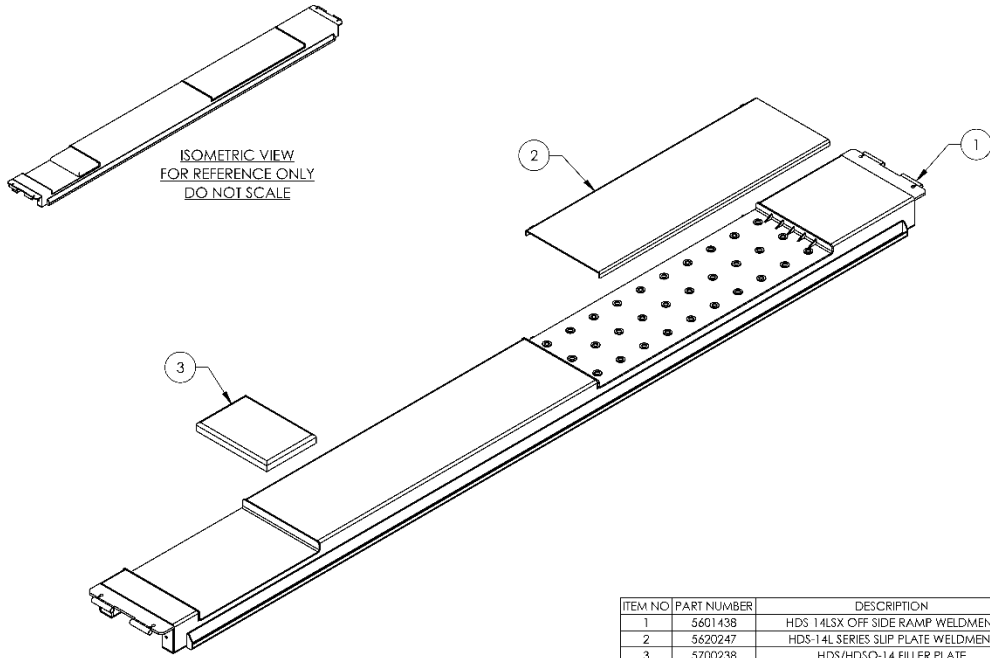

WHERE USED
HDS-14LSX

ITEM NO	PART NUMBER	DESCRIPTION	QTY	REV
1	5601438	HDS 14LSX OFF SIDE RAMP WELDMENT	1	B
2	5620247	HDS-14L SERIES SLIP PLATE WELDMENT	1	A
3	5700238	HDS/HDSO-14 FILLER PLATE	1	A

DO NOT SCALE DRAWING		NAME	DATE	BP BendPak 1645 LEMMONWOOD DR. SANTA ANA, CA 92706
DRAWN	CA	12/06/2019		
CHECKED	OR	02/26/2022		
DIMENSIONS ARE IN MM		THIRD ANGLE PROJECTION		TITLE: HDS-14LSX OFF SIDE RAMP ASSEMBLY
				SIZE: DWG. NO. 5215887 REV B
				SCALE: 1:20 SHEET 1 OF 1

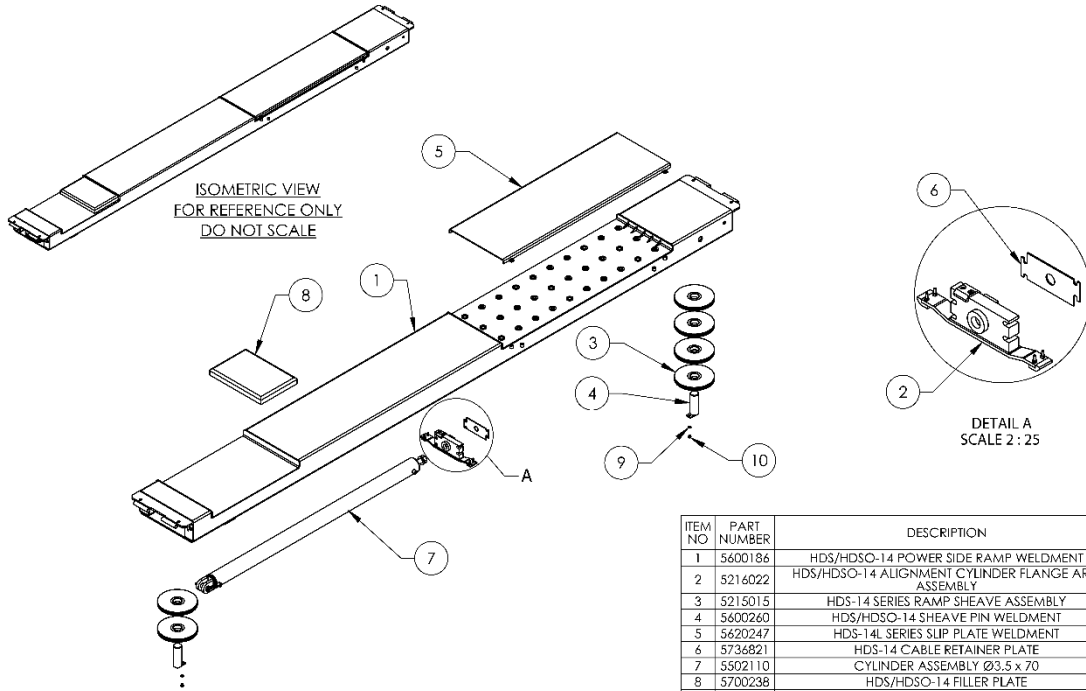

WHERE USED
HDS-14LSX

ITEM NO	PART NUMBER	DESCRIPTION	QTY	REV
1	5600186	HDS/HDSO-14 POWER SIDE RAMP WELDMENT	1	J
2	5216022	HDS/HDSO-14 ALIGNMENT CYLINDER FLANGE ARM ASSEMBLY	1	A
3	5215015	HDS-14 SERIES RAMP SHEAVE ASSEMBLY	6	C
4	5600260	HDS/HDSO-14 SHEAVE PIN WELDMENT	2	C
5	5620247	HDS-14L SERIES SLIP PLATE WELDMENT	1	A
6	5736821	HDS-14 CABLE RETAINER PLATE	1	A
7	5502110	CYLINDER ASSEMBLY Ø3.5 x 70	1	K
8	5700238	HDS/HDSO-14 FILLER PLATE	1	A
9	5545341	WASHER M10 x Ø20 FLAT	2	-
10	5530281	HHB M10 x 1.5 x 10	2	-

DO NOT SCALE DRAWING		NAME	DATE	BP BendPak 1645 LEMMONWOOD DR. SANTA ANA, CA 92706
DRAWN	CA	02/25/2021		
CHECKED	OR	09/15/2021		
DIMENSIONS ARE IN MM		THIRD ANGLE PROJECTION		TITLE: HDS-14LSX POWER SIDE RAMP ASSEMBLY
				SIZE: DWG. NO. 5216019 REV B
				SCALE: 1:30 SHEET 1 OF 2

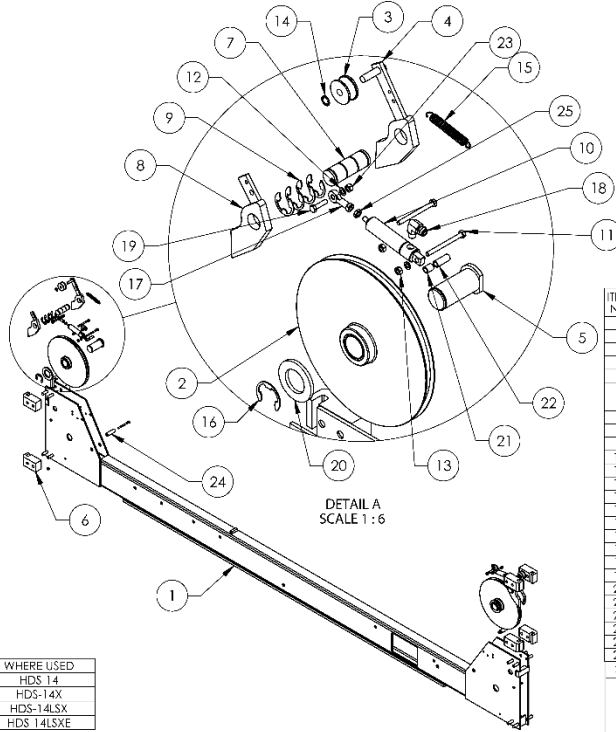

ITEM NO.	PART NUMBER	DESCRIPTION	QTY	REV
1	5601814	HDS-14 CROSSSTUBE WELDMENT, LARGE WINDOW	1	A
2	5215013	HDS-14 CROSSSTUBE SHEAVE ASSEMBLY	2	B
3	5575380	D4-12, HD/HDS/HDSO-14 SAFETY ROLLER	2	C
4	5600044	4 POST LIGHT DUTY SLACK SAFETY WELDMENT	2	F
5	5600173	D4-12, HD/HDS/HDSO-14 SHEAVE PIN WELDMENT	2	G
6	5716005	D4-12, HD-7/7500/9/14/HDSO-14 POLYETHYLENE SLIDE BLOCK	8	M
7	5746008	D4-12, HD/HDS-7/7500/9/14, HDSO-14 SAFETY PIN	2	D
8	5600760	D4-12, HD/HDS LIGHT DUTY SAFETY WELDMENT	2	C
9	5540275	E RING Ø25mm OD DIN 6799 0250	8	-
10	5502195	AIR CYLINDER, Ø19mm x 25 STROKE	2	-
11	5530005	HHB M6 x 1 x 70	6	-
12	5545005	WASHER, M6 x 12mm FLAT	4	-
13	5535112	NUT M6 x 1.0	4	-
14	5505030	PUSH-ON CLIP Ø10mm SS	2	-
15	5540065	SPRING Ø13mm x 90mm, SLACK SAFETY	2	A
16	5540002	E RING Ø1.375" OD TRUARC X5133-137	2	-
17	5505625	FEMALE ROD END M6 x 33	2	-
18	5550087	FTG ELB -04 COMP x -02 NPT	2	-
19	5530756	HHB M6 x 1.0 x 25mm	2	-
20	5545032	WASHER M36 x 66 FLAT	2	-
21	5755136	AIR CYLINDER SPACER 12mm	2	A
22	5755137	AIR CYLINDER SPACER 25mm	2	A
23	5535357	NUT M6 x 1.0 NL	4	-
24	5755157	D4-12, HD-7/7500/9 CROSSSTUBE SPACER Ø16 x Ø10 x 50	2	A
25	5535230	NUT 1/4-28 JN	2	-

30" SCALE DRAWING

DRAWN: TM DATE: 04/28/2022

CHECKED:

BP BendPak
1445 LEMONWOOD DR.
SAN ANTONIO, TX 78203

EMPHASIS ARE IN P.A.

THIRD ANGLE PROJECTION

SMILEY FACE

PROPERTY AND CONFIDENTIAL
THIS DRAWING IS THE PROPERTY OF BENDPAK INC.
IT IS TO BE USED ONLY FOR THE PROJECT AND QUANTITY SPECIFIED.
IF YOU ARE NOT THE PURCHASER, DO NOT REPRODUCE OR DISTRIBUTE.

TITLE: HDS-14 CROSSSTUBE ASSEMBLY, LARGE WINDOW

SIZE: DWG. NO. 5216147 REV A

SCALE: 1:20 SHEET 1 OF 1

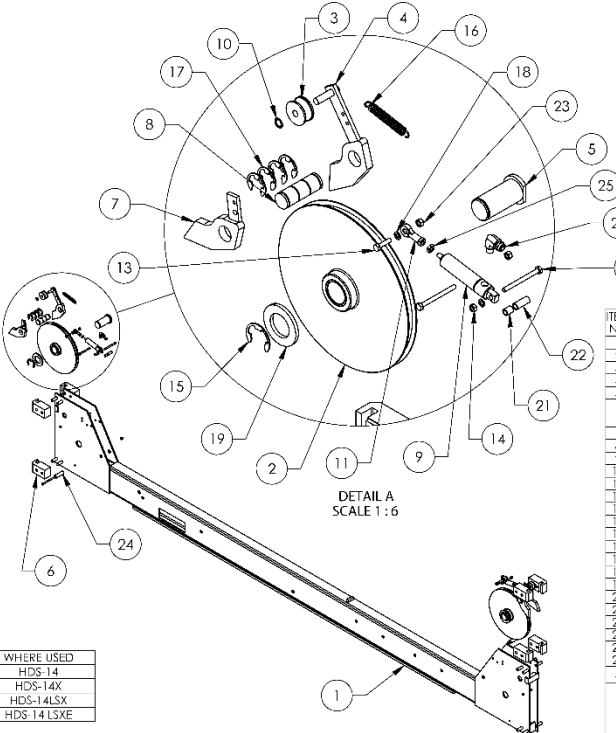

ITEM NO.	PART NUMBER	DESCRIPTION	QTY	REV
1	5601826	HDS-14 CROSSSTUBE WELDMENT, SMALL WINDOW	1	A
2	5215013	HDS-14 CROSSSTUBE SHEAVE ASSEMBLY	2	B
3	5575380	D4-12, HD/HDS/HDSO-14 SAFETY ROLLER	2	C
4	5600044	4 POST LIGHT DUTY SLACK SAFETY WELDMENT	2	F
5	5600173	D4-12, HD/HDS/HDSO-14 SHEAVE PIN WELDMENT	2	G
6	5716005	D4-12, HD-7/7500/9/14/HDSO-14 POLYETHYLENE SLIDE BLOCK	8	M
7	5600760	D4-12, HD/HDS LIGHT DUTY SAFETY WELDMENT	2	C
8	5746008	D4-12, HD/HDS-7/7500/9/14, HDSO-14 SAFETY PIN	2	D
9	5502195	AIR CYLINDER, Ø19mm x 25 STROKE	2	-
10	5505030	PUSH-ON CLIP Ø10mm SS	2	-
11	5505625	FEMALE ROD END M6 x 33	2	-
12	5530005	HHB M6 x 1 x 70	6	-
13	5530756	HHB M6 x 1.0 x 25mm	2	-
14	5535112	NUT M6 x 1.0	4	-
15	5540002	E RING Ø1.375" OD TRUARC X5133-137	2	-
16	5540065	SPRING Ø13mm x 90mm, SLACK SAFETY	2	A
17	5540275	E RING Ø25mm OD DIN 6799 0250	8	-
18	5545005	WASHER, M6 x 12mm FLAT	4	-
19	5545032	WASHER M36 x 66 FLAT	2	-
20	5550087	FTG ELB -04 COMP x -02 NPT	2	-
21	5755136	AIR CYLINDER SPACER 12mm	2	A
22	5755137	AIR CYLINDER SPACER 25mm	2	A
23	5535357	NUT M6 x 1.0 NL	4	-
24	5755157	D4-12, HD-7/7500/9 CROSSSTUBE SPACER Ø16 x Ø10 x 50	2	A
25	5535230	NUT 1/4-28 JN	2	-

30" SCALE DRAWING

DRAWN: TM DATE: 05/22/2022

CHECKED:

BP BendPak
1445 LEMONWOOD DR.
SAN ANTONIO, TX 78203

EMPHASIS ARE IN P.A.

THIRD ANGLE PROJECTION

SMILEY FACE

PROPERTY AND CONFIDENTIAL
THIS DRAWING IS THE PROPERTY OF BENDPAK INC.
IT IS TO BE USED ONLY FOR THE PROJECT AND QUANTITY SPECIFIED.
IF YOU ARE NOT THE PURCHASER, DO NOT REPRODUCE OR DISTRIBUTE.

TITLE: HDS-14 CROSSSTUBE ASSEMBLY, SMALL WINDOW

SIZE: DWG. NO. 5216148 REV A

SCALE: 1:20 SHEET 1 OF 1

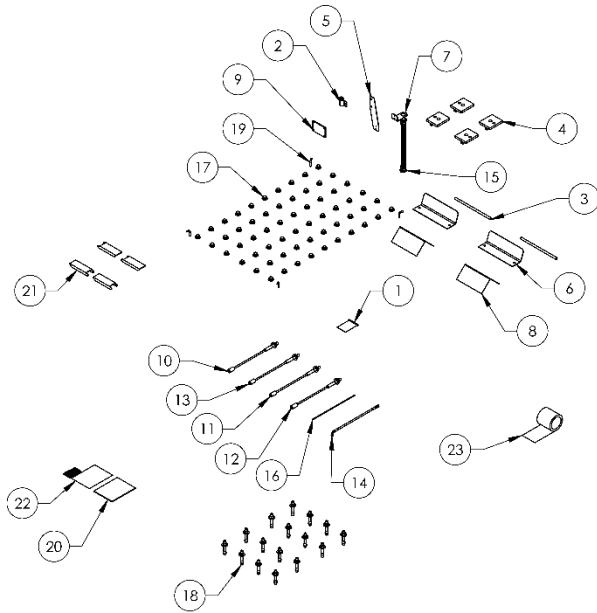

WHERE USED
HDS-14LSX

ITEM NO.	PART NUMBER	DESCRIPTION	QTY	REV
1	5174094	D4-12, HD/HDS-14 PARTS BAG	1	G
2	5215096	PUSH BUTTON AIR ASSEMBLY	1	G
3	5505009	D4-12, HD/HDS-14 DRIVE UP RAMP PIN	2	D
4	5600408	HD/HDS-14 TOP PLATE WELDMENT	4	C
5	5700029	HD SERIES FLEX TUBE BRACKET PLATE	1	F
6	5700032	TIRE STOP	2	D
7	5700033	HD-SERIES FLEX TUBE ANGLE	1	E
8	5700072	WHEEL CHOCK	2	B
9	5716003	POWER UNIT VIBRATION DAMPENER	1	B
10	5595065	HDS/HDSO-14 CABLE ASSEMBLY Ø12 x 4100mm ST	1	E
11	5595066	HDS/HDSO-14 CABLE ASSEMBLY Ø12 x 5732mm ST	1	E
12	5595074	HDS 14/14LSX CABLE ASSEMBLY Ø12 x 9337mm ST	1	D
13	5595075	HDS-14/14LSX CABLE ASSEMBLY Ø12 x 10990mm ST	1	E
14	5570871	HYDRAULIC HOSE ASSEMBLY Ø6.4 x 4166mm	1	B
15	5216139	FLEX TUBE KIT, UP TO 2000mm	1	A
16	5570795	1/4" POLY-FLO TUBING	20000mm*	-
17	5575015	656A SERIES 1" BALL CASTER	60	-
18	5530456	AB 3/4" x 4 3/4"	16	-
19	5745050	SLIP PLATE LOCK PIN	4	A
20	5900162	HDS-14 ALIGNMENTS INSTALLATION MANUAL	1	-
21	5716629	HDS-14 CROSSTUBE COVER, PLASTIC	4	A
22	5210241	4 POST LIGHT DUTY CE PARTS BAG	1	A
23	5930195	ANTI-SLIP TAPE, 6" x 24ft	1	--

DO NOT SCALE DRAWING

NAME DATE

DRAWN: TBL 05/02/2013

CHECKED: OX 03/09/2022

THIRD ANGLE PROJECTION

PROPRIETARY AND CONFIDENTIAL
THIS DRAWING IS THE PROPERTY OF BENDPAK INC. ANY REPRODUCTION OR TRANSMISSION OF THIS DRAWING WITHOUT THE WRITTEN PERMISSION OF BENDPAK INC. IS PROHIBITED.

BendPak
1645 LEMONWOOD DR.
SANTA PAULA, CA 93060

TITLE: HDS-14LSX PARTS BOX

SIZE DWG. NO. REV

A 5250194 N

SCALE: 1:35 SHEET 1 OF 1

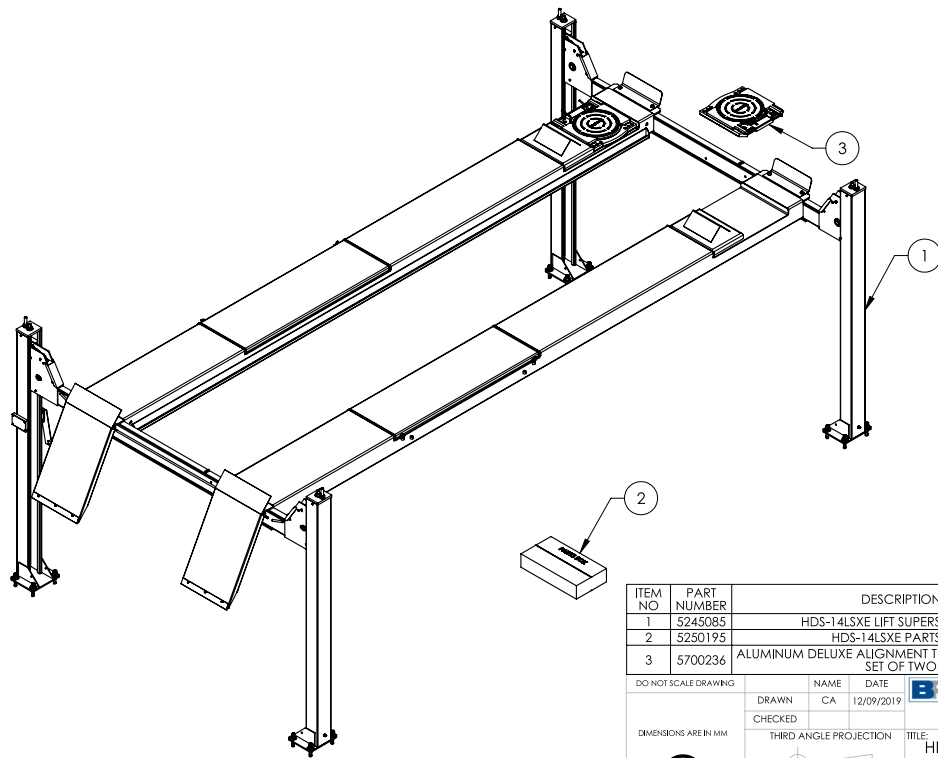

ITEM NO.	PART NUMBER	DESCRIPTION	QTY	REV
1	5245085	HDS-14LSXE LIFT SUPERSTRUCTURE	1	J
2	5250195	HDS-14LSXE PARTS BOX	1	N
3	5700236	ALUMINUM DELUXE ALIGNMENT TURNPLATE ASSEMBLY, SET OF TWO	1	-

DO NOT SCALE DRAWING

NAME DATE

DRAWN: CA 12/09/2019

CHECKED:

THIRD ANGLE PROJECTION

PROPRIETARY AND CONFIDENTIAL
THIS DRAWING IS THE PROPERTY OF BENDPAK INC. ANY REPRODUCTION OR TRANSMISSION OF THIS DRAWING WITHOUT THE WRITTEN PERMISSION OF BENDPAK INC. IS PROHIBITED.

BendPak
1645 LEMONWOOD DR.
SANTA PAULA, CA 93060

TITLE: HDS-14LSXE PRODUCTION LIFT VER D (CE CERT)

SIZE DWG. NO. REV

A 5260601 L

SCALE: 1:35 SHEET 1 OF 3

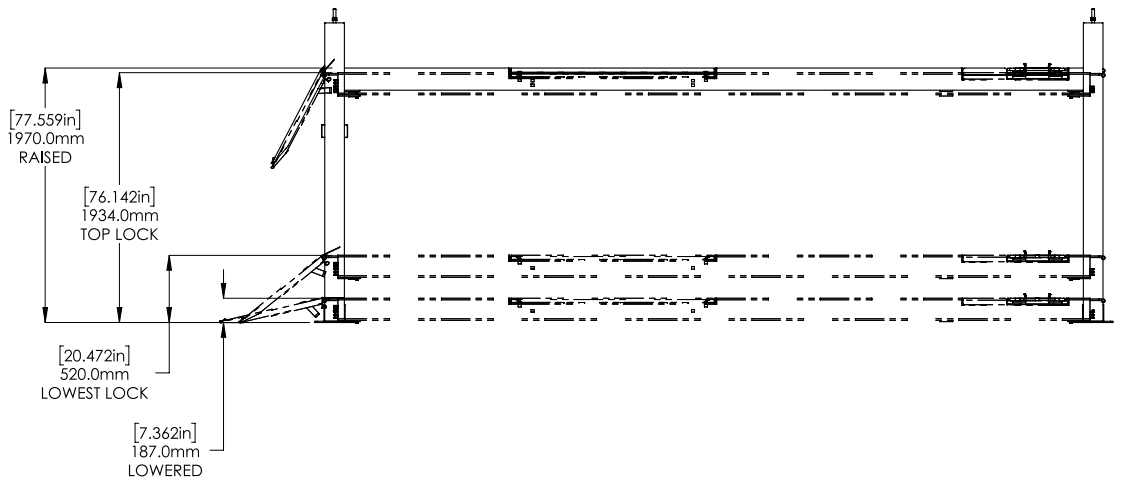
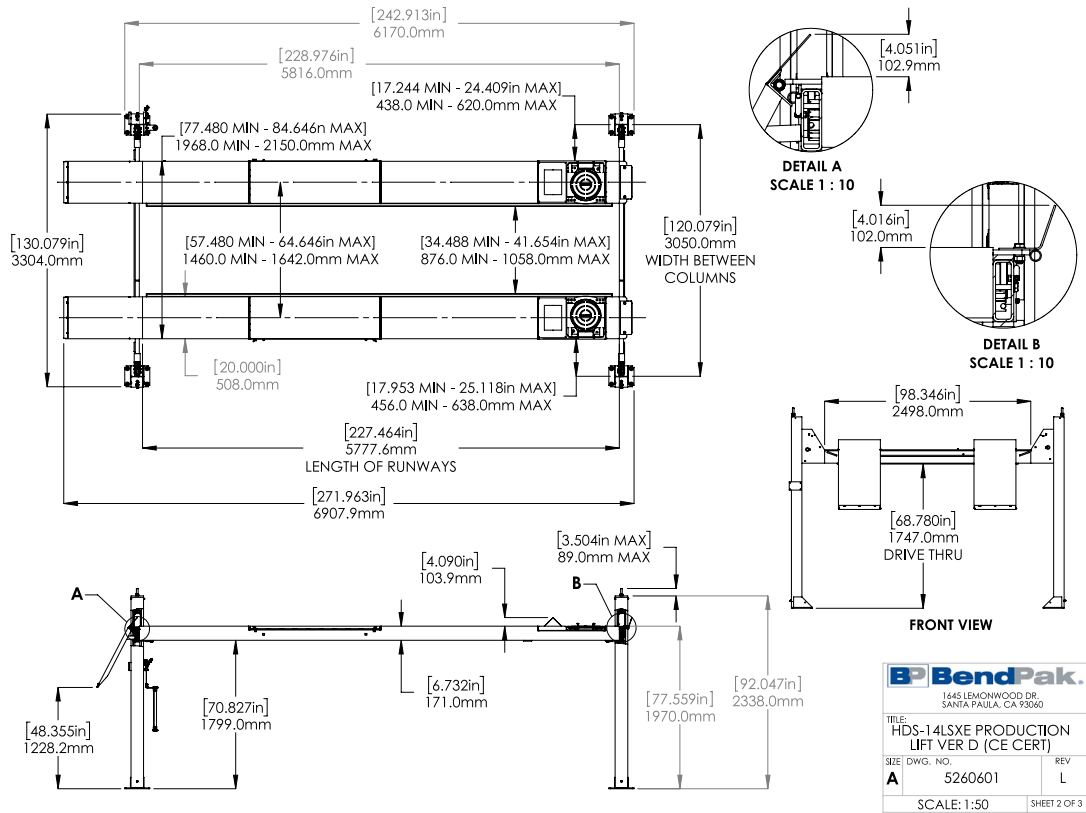

1. DIMENSIONS SHOWN ARE WITH THE LOCK LADDERS ADJUSTED ALL THE WAY UP

BP BendPak.
1645 LEMONWOOD DR.
SANTA PAULA, CA 93060

TITLE: HDS-14LSXE PRODUCTION LIFT VER D (CE CERT)

SIZE: DWG. NO. REV

A 5260601 L

SCALE: 1:35 SHEET 3 OF 3

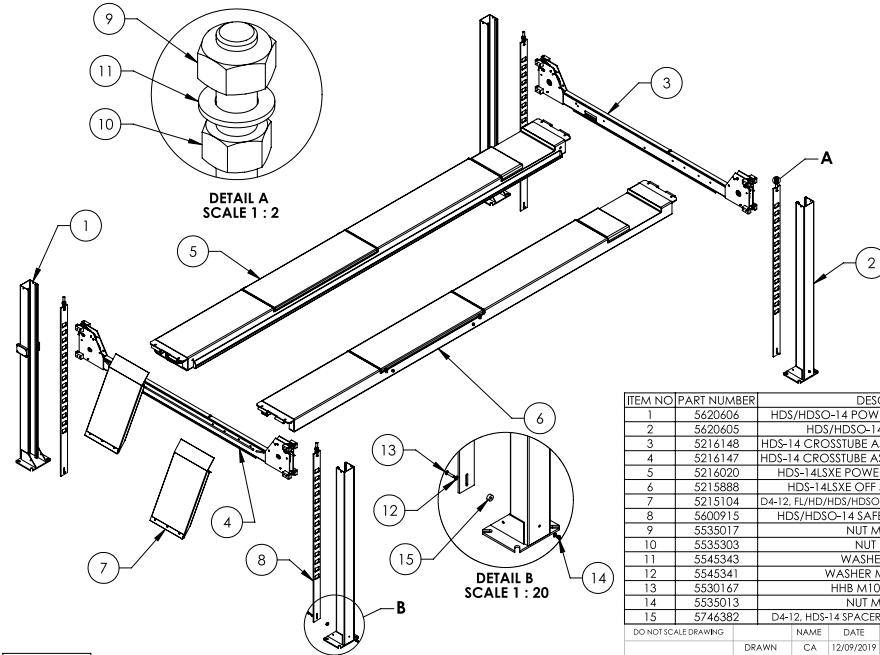

WHERE USED
HDS-14LSXE

ITEM NO	PART NUMBER	DESCRIPTION	QTY	REV
1	5620606	HDS/HDSO-14 POWER SIDE POST WELDMENT	1	C
2	5620605	HDS/HDSO-14 POST WELDMENT	3	C
3	5216148	HDS-14 CROSSTUBE ASSEMBLY, SMALL WINDOW	1	A
4	5216147	HDS-14 CROSSTUBE ASSEMBLY, LARGE WINDOW	1	A
5	5216020	HDS-14LSXE POWER SIDE RAMP ASSEMBLY	1	B
6	5215888	HDS-14LSXE OFF SIDE RAMP ASSEMBLY	1	B
7	5215104	D4-12, FLJHD/HDS/HDSO-14 DRIVE UP RAMP ASSEMBLY	2	K
8	5600915	HDS/HDSO-14 SAFETY LADDER WELDMENT	4	B
9	5535017	NUT M20 x 2.5 NL	4	-
10	5535303	NUT M20 x 2.5	4	-
11	5545343	WASHER, M20 FLAT	4	-
12	5545341	WASHER M10 x Ø20 FLAT	8	-
13	5530167	HHB M10 x 1.5 x 45mm	4	-
14	5535013	NUT M10 x 1.5 NL	4	-
15	5746382	D4-12, HDS-14 SPACER, SAFETY LADDER, 15mm LG	4	A

DO NOT SCALE DRAWING

DRAWN: CA 12/09/2019
 CHECKED: CA 02/26/2022

NAME: DATE: **BP BendPak**
 1445 LEMONWOOD DR.
 SANTA PAULA, CA 93060

THIRD ANGLE PROJECTION

TITLE: HDS-14LSXE LIFT SUPERSTRUCTURE

SIZE: DWG. NO. 5245085 REV J

SCALE: 1:45 SHEET 1 OF 1

PROPRIETARY AND CONFIDENTIAL
 THE BENDPAK LIFT COMPANY IS THE SOLE OWNER OF THE BENDPAK LIFT SYSTEMS. ALL RIGHTS ARE RESERVED. BENDPAK LIFT SYSTEMS IS A TRADEMARK OF BENDPAK LIFT COMPANY.

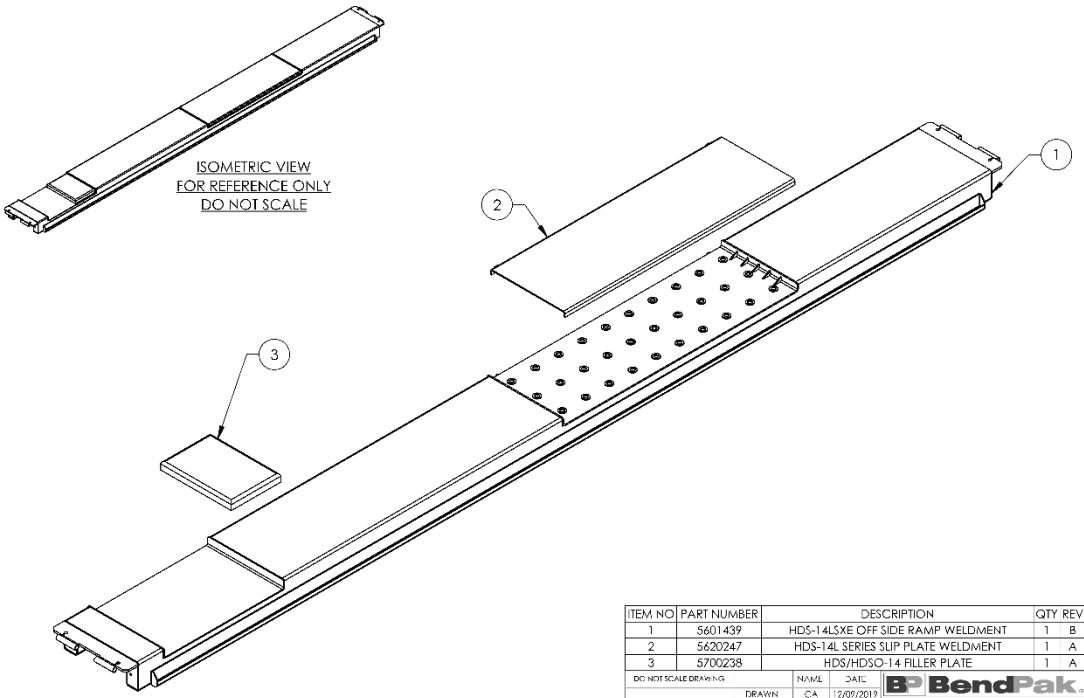

WHERE USED
HDS-14LSXE

ITEM NO	PART NUMBER	DESCRIPTION	QTY	REV
1	5601439	HDS-14LSXE OFF SIDE RAMP WELDMENT	1	B
2	5620247	HDS-14L SERIES SLIP PLATE WELDMENT	1	A
3	5700238	HDS/HDSO-14 FILLER PLATE	1	A

DO NOT SCALE DRAWING

DRAWN: CA 12/09/2019
 CHECKED: CA 02/26/2022

NAME: DATE: **BP BendPak**
 1445 LEMONWOOD DR.
 SANTA PAULA, CA 93060

THIRD ANGLE PROJECTION

TITLE: HDS-14LSXE OFF SIDE RAMP ASSEMBLY

SIZE: DWG. NO. 5215888 REV B

SCALE: 1:20 SHEET 1 OF 1

PROPRIETARY AND CONFIDENTIAL
 THE BENDPAK LIFT COMPANY IS THE SOLE OWNER OF THE BENDPAK LIFT SYSTEMS. ALL RIGHTS ARE RESERVED. BENDPAK LIFT SYSTEMS IS A TRADEMARK OF BENDPAK LIFT COMPANY.

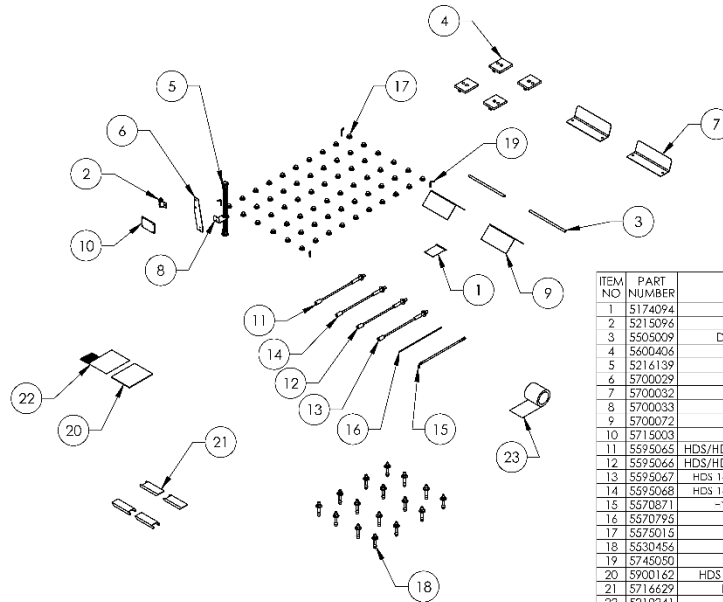

WHERE USED
HDS-14LSXE

ITEM NO	PART NUMBER	DESCRIPTION	QTY.	REV
1	5174094	D4-12, HD/HDS-14 PARTS BAG	1	G
2	5215096	PUSH BUTTON AIR ASSEMBLY	1	G
3	5505009	D4-12, HD/HDS-14 DRIVE UP RAMP PIN	2	D
4	5600406	HD/HDS-14 TOP PLATE WELDMENT	4	C
5	5216139	FLEX TUBE KIT, UP TO 2000mm	1	A
6	5700029	HD-SERIES FLEX TUBE BRACKET PLATE	1	F
7	5700032	TIRE STOP	2	D
8	5700033	HD-SERIES FLEX TUBE ANGLE	1	E
9	5700072	WHEEL CHOCK	2	B
10	5715003	POWER UNIT VIBRATION DAMPENER	1	B
11	5595065	HDS/HDSO-14 CABLE ASSEMBLY Ø12 x 4100mm ST	1	E
12	5595066	HDS/HDSO-14 CABLE ASSEMBLY Ø12 x 5732mm ST	1	E
13	5595067	HDS 14X/14LSXE CABLE ASSEMBLY Ø12 x 10076mm ST	1	E
14	5595068	HDS 14X/14LSXE CABLE ASSEMBLY Ø12 x 1751mm ST	1	E
15	5570871	-YDRALIC HOSE ASSEMBLY Ø6.4 x 41 66mm	1	B
16	5570795	1/4" POLY FLO TUBING	20000mm*	-
17	5575016	656A SERIES 1" BALL CASTER	60	-
18	5530456	AB 3/4" x 4 - 3/4"	16	-
19	5745050	SLIP PLATE LOCK PIN	4	A
20	5900162	HDS 14 ALIGNMENTS INSTALLATION MANUAL	1	-
21	5716629	HDS 14 CROSSTUBE COVER, PLASTIC	4	A
22	5210241	4 POST LIGHT DUTY CE PARTS BAG	1	A
23	5930195	ANTI SLIP TAPE, 6" x 24ft	1	-

DO NOT SCALE DRAWING	NAME	DATE	BendPak 1645 LEMONWOOD DR. SANTA PAULA, CA 93060	
DRAWN	TM	05/02/2013	HDS-14LSXE PARTS BOX TITLE: HDS-14LSXE PARTS BOX SIZE DWG. NO. A 5250195 REV N	
CHECKED	OR	05/09/2022		
DIMENSIONS ARE IN MM			SCALE: 1:35 SHEET 1 OF 1	

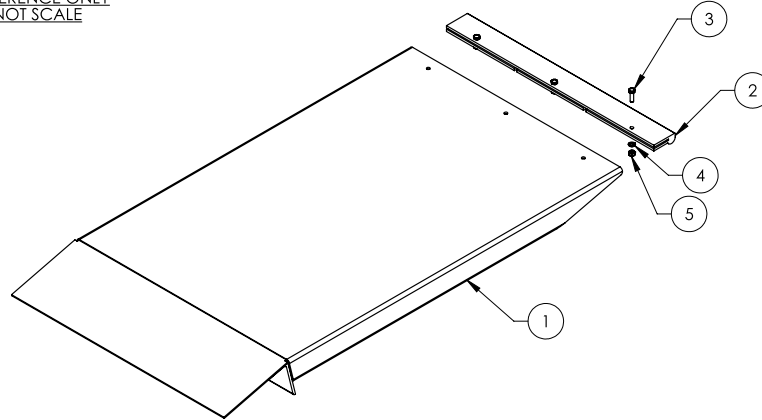
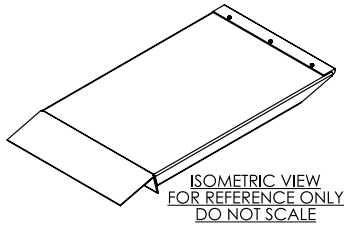

WHERE USED
D4-12 SERIES
FL14 SERIES
HD-14T
HDS-14 SERIES
HDSO-14 SERIES

ITEM NO	PART NUMBER	DESCRIPTION	QTY.	REV
1	5600138	D4-12, HD/HDS/HDSO-14 DRIVE UP RAMP WELDMENT	1	H
2	5716087	HDS-14 APPROACH RAMP EDGE GUARD	1	A
3	5530093	HHB M6 x 1.0 x 20mm	3	-
4	5545005	WASHER, M6 x 12mm FLAT	3	-
5	5535357	NUT M6 x 1.0, NL CL8	3	-

DO NOT SCALE DRAWING	NAME	DATE	BendPak 1645 LEMONWOOD DR. SANTA PAULA, CA 93060	
DRAWN	TM	06/04/2008	D4-12, FL/HD/HDS/HDSO-14 DRIVE UP RAMP ASSEMBLY TITLE: D4-12, FL/HD/HDS/HDSO-14 DRIVE UP RAMP ASSEMBLY SIZE DWG. NO. A 5215104 REV K	
CHECKED	OR	12/13/2022		
DIMENSIONS ARE IN MM			SCALE: 1:8 SHEET 1 OF 2	

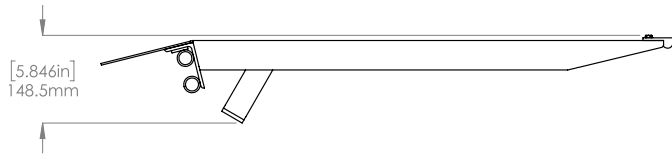
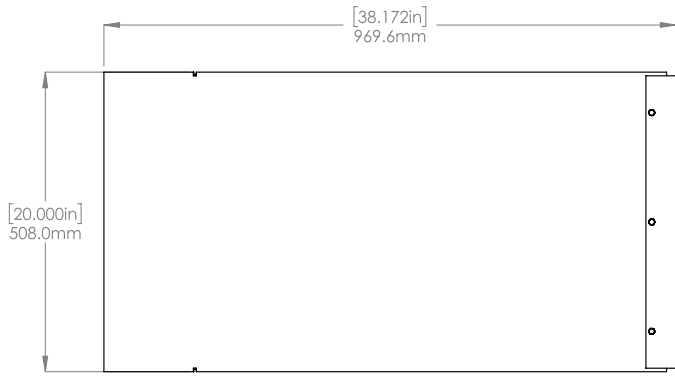

 1645 LEMONWOOD DR. SANTA PAULA, CA 93060		
TITLE: D4-12, FL/HD/HDS/HDSO- 14 DRIVE UP RAMP		
SIZE	DWG. NO.	ASSEMBLY
A	5215104	K
SCALE: 1:8		SHEET 2 OF 2



EC Type-Examination Certificate



(Fm 210-017, Rev.10)

For the requirements of the Machinery Directive 2006/42/EC

For Annex IV machinery

Certificate No.: CE-C-20120209-01-04-5B
Date of first issue: 2014.01.27
Date of last review: 2019.01.27
Date of next review: 2024.01.26

NAME AND ADDRESS OF THE MANUFACTURER: Bendpak Inc.
1645 E. Lemonwood Drive, Santa Paula, CA, United States of America

PRODUCT DESCRIPTION/ TYPE AND MODEL: 4 Post Alignment Vehicle Servicing Lifts 14000lb (6350kg) Capacity
HDS-14LSX 130W x 241L x 70H in
HDS-14LSXE 130W x 271L x 70H in

APPLICABLE STANDARDS: EN1493:2010 Vehicle Lifts
EN 60204-1:2006+A1:2009 Safety of machinery - Electrical equipment of machines - Part1:General requirements

A COPY IS AVAILABLE FROM: CCQS UK Ltd., 5 Harbour Exchange, London, E14 9GE, UK

SUBJECT TO THESE CONDITIONS: A Rolling Jack is not included in this certification.

RE-ISSUE HISTORY CE-C-20120209-01-04-5A first issue
CE-C-20120209-01-04-5B this issue – Review of original certification

The technical file, accompanying documentation and the equipment which they describe have been found to be in compliance with the requirements of the Machinery Directive 2006/42/EC.

The responsible person defined above has responsibility for ensuring that all future serial manufacture of the machinery conforms to the sample submitted for EC type-examination referenced above.

Any changes to the design of the machinery certified here must be advised to CCQS UK Ltd. for re-assessment.

A CE marking should not be fixed to the equipment until the requirements of all relevant directives have been met.

Approved by: Owen Bian – Office Manager

Date: 2019.01.27

Appointed by UK Government
as a Notified Body
for CE Marking No. 1105

CCQS UK Ltd.,
5 Harbour Exchange, Canary Wharf,
London, E14 9GE, UK
Tel: +44 (0) 20 7868 1509
Email info@ccqs.co.uk

If in any doubt about the integrity of this certificate,
please verify it on our website at
<http://www.ccqs.co.uk>



Declaration of Conformity

The equipment which accompanies this declaration is in conformity with EU Directive:
2006/42/EC Machinery Directive

Manufacturer
 BendPak Inc.
 1645 Lemonwood Dr.
 Santa Paula, CA 93060,
 USA

A copy of the technical file for this equipment is available from:
 CCQS UK Ltd.,
 level 7, Westgate House, Westgate Rd.,
 London W5 1YY UK

Description of Equipment

Vehicle Servicing Lifts						
Model	Capacity (lb)	Design	Width(in)	Legth(in)	Max Lift(in)	
HDS-14LSX	14,000	4 Post Alignment	130	241	70	
HDS-14LSXE	14,000	4 Post Alignment	130	271	70	

A sample of this machinery has been presented to Notified Body number 1105.
 CCQS UK Ltd., level 7, Westgate House, Westgate Rd., London W5 1YY UK
 Who have issued an EC-type examination certificate
 Number CE-GB-20120209-01-04-5A dated 2014.01.27

The equipment in respect of which this declaration is made conforms to the example to which that certificate relates, and that certificate remains valid.

The following harmonised standards have been used:-
 EN 1493:2010 Vehicle Lifts

Authorised signatory of manufacturer

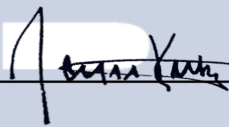
Signature: 

Name of signatory: Jeff Kritzer
Position in company: SVP Sales/Marketing

Place signed: Santa Paula CA
Date signed: 11.6.2013



BendPak®

30440 Agoura Rd.
Agoura Hills, CA 91301 USA
bendpak.com