

Clear Floor Two-Post Lifts

Installation and Operation Manual

Manual P/N 5900377 — Manual Revision A1 — June 2024

Models:

- 16AP
- 16AP-192
- 20AP
- 20AP-192

*Original instructions in
the English language*

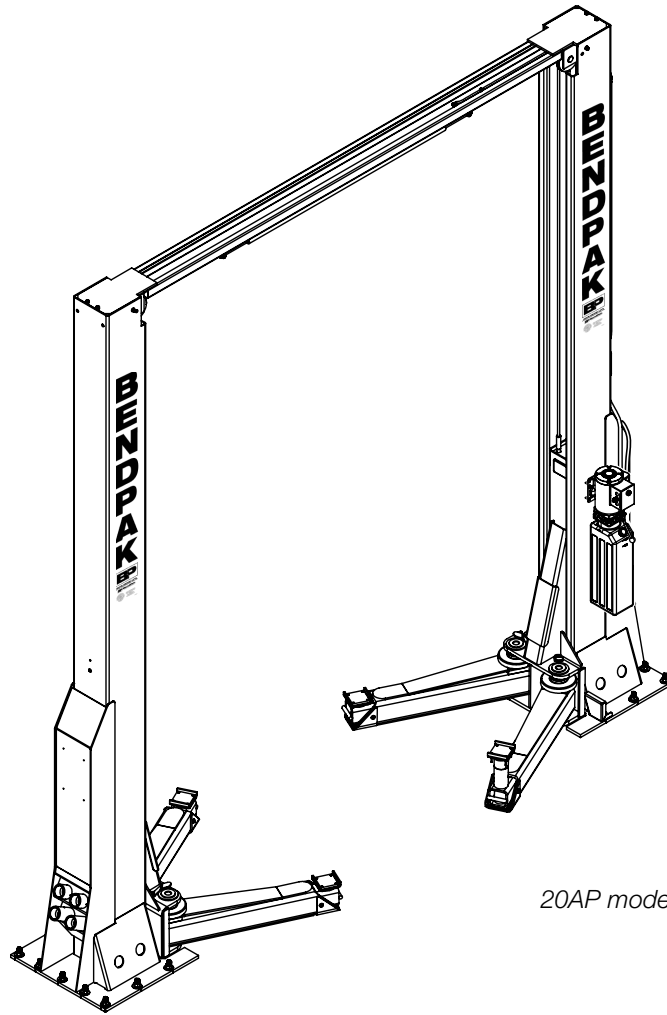

20AP model shown above.

Designed and engineered by BendPak Inc. in Southern California, USA. Made in China.

 **DANGER**

IMPORTANT Safety Instructions, save these instructions! Read the *entire contents* of this manual *before* using this product. Failure to follow the instructions and safety precautions in this manual can result in severe injury or death. Make sure all other operators also read this manual. Keep the manual near the product for future reference. *By proceeding with setup and operation, you agree that you fully understand the contents of this manual and assume full responsibility for product use.*

Manual. 16AP and 20AP Series Two-Post Lifts, *Installation and Operation Manual*, Manual Part Number 5900377, Manual Revision A1, released June 2024.

Copyright. Copyright ©2024 by BendPak Inc. All rights reserved. You may make copies of this document if you agree that: full attribution goes to BendPak Inc., you are not authorized to make changes to the content, you do not gain any rights to this content, and you will not use the copies for commercial purposes.

Trademarks. BendPak and the BendPak logo are registered trademarks of BendPak Inc. All other company, product, and service names are used for identification only. All trademarks and registered trademarks mentioned in this manual are the property of their respective owners.

Limitations. Every effort has been made to ensure complete and accurate instructions are included in this manual. However, product updates, revisions, and/or changes may have occurred since this manual was published. BendPak reserves the right to change any information in this manual without incurring any obligation for equipment previously or subsequently sold. All drawings are reference only – do not scale. BendPak is not responsible for typographical errors in this manual. You can always find the latest version of the **manual for your product on the BendPak website.**



SCAN FOR
DIGITAL PDF

Warranty. The BendPak warranty is more than a commitment to you: it is also a commitment to the value of your new product. Contact your nearest BendPak dealer or visit www.bendpak.com/support/warranty for full warranty details. Go to bendpak.com/support/register-your-product/ and fill out the online form to register your product (be sure to click **Submit**).

Safety. Your Lift was designed and manufactured with safety in mind. Your safety also depends on proper training and thoughtful operation. Do not set up, operate, maintain, or repair the Lift without reading and understanding this manual and the labels on the unit; **do not use your Lift unless you can do so safely!**

Owner Responsibility. In order to maintain your product properly and to ensure operator safety, it is the responsibility of the product owner to read and follow these instructions:

- Follow all installation, operation, and maintenance instructions.
- Make sure product installation conforms to all applicable local, state, and federal codes, rules, and regulations, such as state and federal OSHA regulations and electrical codes.
- Read and follow all safety instructions. Keep them readily available for operators.
- Make sure all operators are properly trained, know how to safely operate the unit, and are properly supervised.
- Do not operate the product until you are certain all parts are in place and operating correctly.
- Carefully inspect the product on a regular basis and perform all maintenance as required.
- Service and maintain the unit only with approved replacement parts.
- Keep the manual with the product and make sure all labels are clean and visible.
- **BendPak** makes no promises, guarantees or assurances that our products meet any state, county, federal or international mandated permit, license, code, standard, certification, or any other mandate other than what is listed or shown on BendPak website(s), or any BendPak or Ranger online or published catalog. Not all BendPak Lift models meet the standards as prescribed by ANSI/ALI ALCTV-(current edition) or ANSI/UL 201. Consult www.autolift.org for a complete list of Lift models that meet ANSI/ALI ALCTV-(current edition) or ANSI/UL 201 or contact BendPak via contact@bendpak.com. **Buyer assumes full responsibility for any state, county, federal or international mandated permit, license, code, standard, certification, or any other mandate required related to the installation and/or operation of any BendPak product.** BendPak will not be responsible for any charges, fines, liens, or other levies imposed on the Buyer related to any special or regional structural, seismic or any other building code and/or codes such as the Uniform Building Code (UBC), International Building Code (IBC), or any other state, county, federal or international mandated permit, license, code, standard, certification, or other mandate, law, rule, regulation or directive by any other agency, government, administrations, or corporations whether state, county, federal, or international mandated.

Only use the Lift if it can be used safely!

Unit Information. Enter the Model Number, Serial Number, and the Date of Manufacture from the ID label on your unit. This information is required for part or warranty issues.

Model: _____

Serial: _____

Date of Manufacture: _____

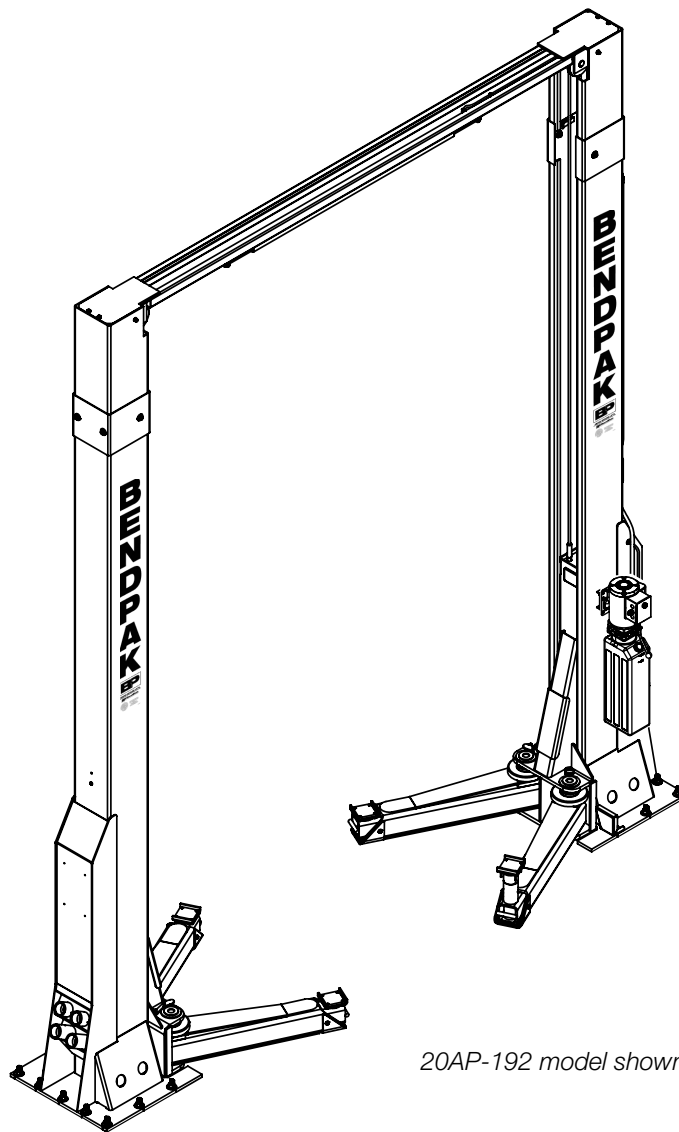

20AP-192 model shown above.

Table of Contents

Introduction	4	Maintenance	73
Shipping Information	5	Troubleshooting	78
Safety Considerations	5	Wiring Diagrams	83
Components	8	Labels	89
Specifications	9	Parts Drawings	92
Installation Checklist	12	ALI Store	109
Installation	13	Maintenance Log	110
Operation	63		

Introduction

This manual describes four BendPak Two-Post Lift models:

- **16AP.** A Two-Post Lift with an overall height of 169 in. (4,294 mm) that raises Vehicles up to 16,000 pounds (7,258 kg).
- **16AP-192.** A Two-Post Lift with overall height of 193 in. (4,904 mm) that raises Vehicles up to 16,000 pounds (7,258 kg).
- **20AP.** A Two-Post Lift with an overall height of 169 in. (4,294 mm) that raises Vehicles up to 20,000 pounds (9,072 kg).
- **20AP-192.** A Two-Post Lift with overall height of 193 in. (4,904 mm) that raises Vehicles up to 20,000 pounds (9,072 kg).

All 16AP and 20AP series models feature Overhead Assemblies and clear floors.

⚠ DANGER Be very careful when installing, operating, maintaining, or repairing this equipment; failure to do so could result in property damage, product damage, injury, or (in very rare cases) death. Make sure only authorized personnel operate this equipment. All repairs must be performed by an authorized technician. Do not make modifications to the unit; this voids the warranty and increases the chances of injury or property damage. Make sure to read and follow the instructions on the labels on the unit.

This manual is mandatory reading for all users of 16AP and 20AP Series Two-Post Lifts, including anyone who installs, operates, maintains, or repairs them. Always keep this manual on or near the equipment.

Technical support and service is available from your dealer, on the Web at bendpak.com/support, by email at support@bendpak.com, or by phone at **(800) 253-2363** select option 4, then 7.

Online chat is also available at www.bendpak.com click the chat icon.



Scan this QR Code for up-to-date information and videos on BendPak's Lift series.



SCAN FOR VIDEO

Shipping Information

Your equipment was carefully checked before shipping. Nevertheless, you should thoroughly inspect the shipment **before** you sign to acknowledge that you received it.

When you sign the bill of lading, it tells the carrier that the items on the invoice were received in good condition. **Do not sign the bill of lading until after you have inspected the shipment.** If any of the items listed on the bill of lading are missing or damaged, do not accept the shipment until the carrier makes a notation on the bill of lading that lists the missing or damaged goods.

If you discover missing or damaged goods **after** you receive the shipment and have signed the bill of lading, notify the carrier at once and request the carrier to make an inspection. If the carrier will not make an inspection, prepare a signed statement to the effect that you have notified the carrier (on a specific date), and that the carrier has failed to comply with your request.

It is difficult to collect for loss or damage after you have given the carrier a signed bill of lading. If this happens to you, file a claim with the carrier promptly. Support your claim with copies of the bill of lading, freight bill, invoice, and photographs, if available. Our willingness to assist in helping you process your claim does not make us responsible for collection of claims or replacement of lost or damaged materials.

Safety Considerations

Read this entire manual carefully before using your new product. Do not install or operate the product until you are familiar with all operating instructions and warnings. Do not allow anyone else to operate the product until they are familiar with all operating instructions and warnings.

 **WARNING California Proposition 65.** This product can expose you to chemicals including styrene and vinyl chloride which are on the list of over 900 chemicals identified by the State of California to cause cancer, birth defects or reproductive harm. Always use this product in accordance with BendPak's instructions. For more information, visit www.p65warnings.ca.gov.

Important Safety Information

When using this equipment, basic safety precautions should always be followed, including:

1. Read all instructions. Use only as described in this manual.
2. Only operate your Lift between temperatures of 41°F to 104°F (5°C to 40°C).
3. Make sure all operators read and understand this *Installation and Operation Manual*. **Keep the manual near the Lift at all times.**
4. BendPak recommends referring to the ANSI/ALI ALIS Standard *Safety Requirements for Installation and Service* for more information about safely installing, using, and servicing your Lift.
5. The Lift should only be operated by authorized personnel. Keep children and untrained personnel away from the Lift.
6. Do not make any modifications to the Lift; this voids the warranty and increases the chances of injury or property damage. Use only factory-approved attachments.
7. Do not use the Lift while tired or under the influence of drugs, alcohol, or medication.

-
8. Do not touch hot parts; you could be burned. Always use care with the equipment.
 9. Do not operate equipment with a damaged cord or if the equipment has been dropped or damaged – until it has been examined by a qualified service person.
 10. Do not let a cord hang over the edge of a table, bench, or counter or come in contact with hot manifolds or moving fan blades. Loop the power cord around equipment when storing.
 11. If an extension cord is necessary, a cord with a current rating equal to or greater than that of the equipment should be used. Cords rated for less current than the equipment may overheat. Care should be taken to arrange the cord so that it will not be tripped over or pulled out.
 12. Always unplug equipment from electrical outlets when not in use. Never use the cord to pull the plug from the outlet. Grasp plug and pull to disconnect.
 13. To reduce the risk of a fire, do not operate equipment in the vicinity of open containers of flammable liquids (like gasoline).
 14. Adequate ventilation should be provided when working on operating internal combustion engines.
 15. Keep hair, loose clothing, fingers, and all parts of the body away from moving parts.
 16. To reduce the risk of electric shock, do not use the unit on wet surfaces or expose to rain.
 17. **Always wear safety glasses!** Everyday glasses only have impact resistant lenses, they are not safety glasses.

Save these instructions!

Additional Safety Information



The following safety information applies to all BendPak 16AP and 20AP Series Two-Post Lift models:

18. **16AP and 20AP Series Lifts** are Two-Post Service Lifts. **Use them only for their intended purpose.**
19. You must wear OSHA-approved (publication 3151) personal protective equipment **at all times** when installing, using, maintaining, or repairing the Lift. Leather gloves, steel-toed work boots, eye protection, back belts, and hearing protection are **mandatory**.
20. **Never** exceed the rated capacity of the Lift.
21. When the Lift is in use, keep hands and all body parts well away from it.
22. Keep loads balanced on the Lift Arm Assemblies. Clear the area immediately if a Vehicle is in danger of falling off the Lift.
23. Modifications void the warranty and increases the chances of injury or property damage. **Do not modify any safety-related features in any way.**
24. The Lift uses electrical energy; if your organization has Lockout/Tagout policies, make sure to implement them after connecting the Lift to a power source.
25. When handling the Hydraulic components, **always wear safety gloves!** In rare cases, a needle-like stream of Hydraulic Fluid (even at low pressure) can penetrate fingers, hands, or arms. Such a puncture can feel like a bite, electric shock, or a prick. While it may seem like a minor issue, any amount of Hydraulic Fluid injected into the human body is a serious issue. Anyone suffering such a puncture wound should be **immediately** taken as an emergency to the hospital to determine the extent of the injury. Explain the circumstances of the injury to the attending physician, including what type of Hydraulic Fluid was involved. Do not assume a puncture wound that could have been caused by Hydraulic Fluid is a minor issue; it could be life-threatening.

-
26. Make a visual inspection of the Lift before using it. Do not use the Lift if you find any missing or damaged parts. Instead, take it out of service, then contact an authorized repair facility, your distributor, or BendPak at **(805) 933-9970** select option 7, then 4 or email support@bendpak.com.
27. BendPak recommends making a **thorough** inspection of the Lift at least once a year. Replace any damaged or severely worn parts, decals, or warning labels.

Symbols

Following are symbols used in this manual:

-  **DANGER** Calls attention to a hazard that **will** result in death or injury.
-  **WARNING** Calls attention to a hazard or unsafe practice that **could** result in death or injury.
-  **CAUTION** Calls attention to a hazard or unsafe practice that could result in personal injury, product damage, or property damage.
- NOTICE** Calls attention to a situation that could result in product or property damage.

Liability Information

BendPak assumes **no** liability for damages resulting from:

- Use of the equipment for purposes other than those described in this manual.
- Modifications to the equipment without prior, written permission from BendPak.
- Injury or death caused by modifying, disabling, overriding, or removing safety features.
- Damage to the equipment from external influences.
- Incorrect operation of the equipment.

Components

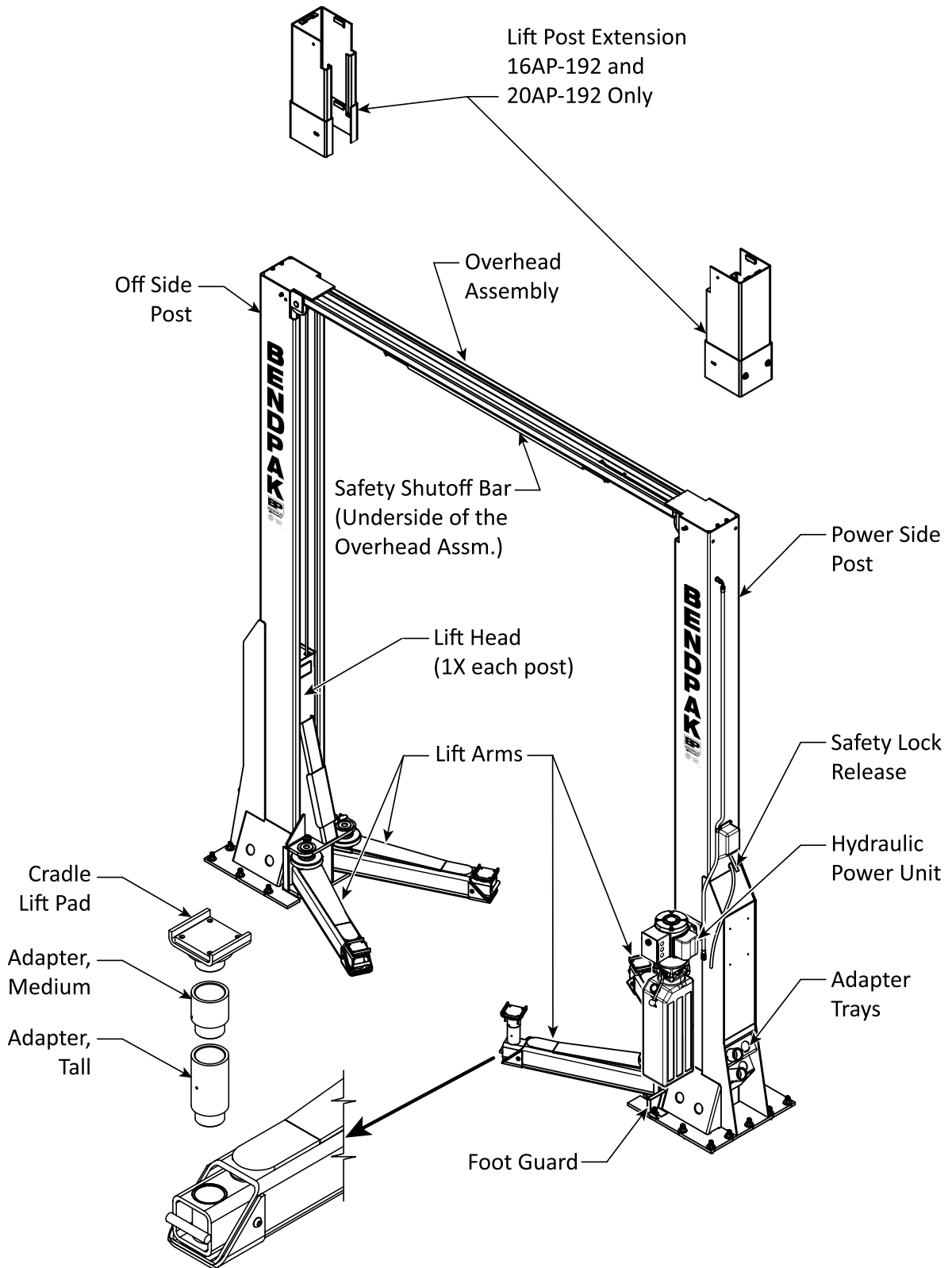

Not all components shown. Models with extensions are taller. Reference only – do not scale.

Specifications

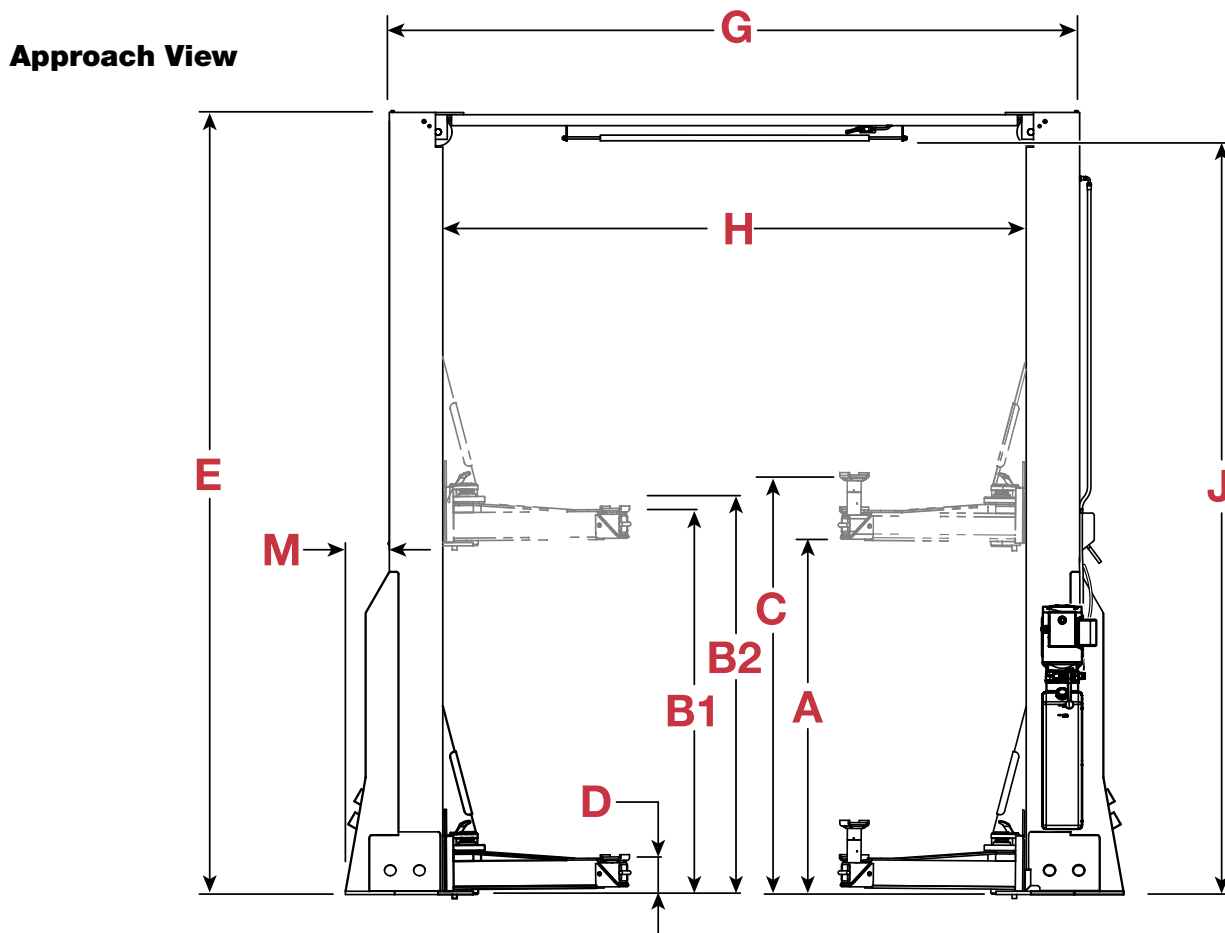
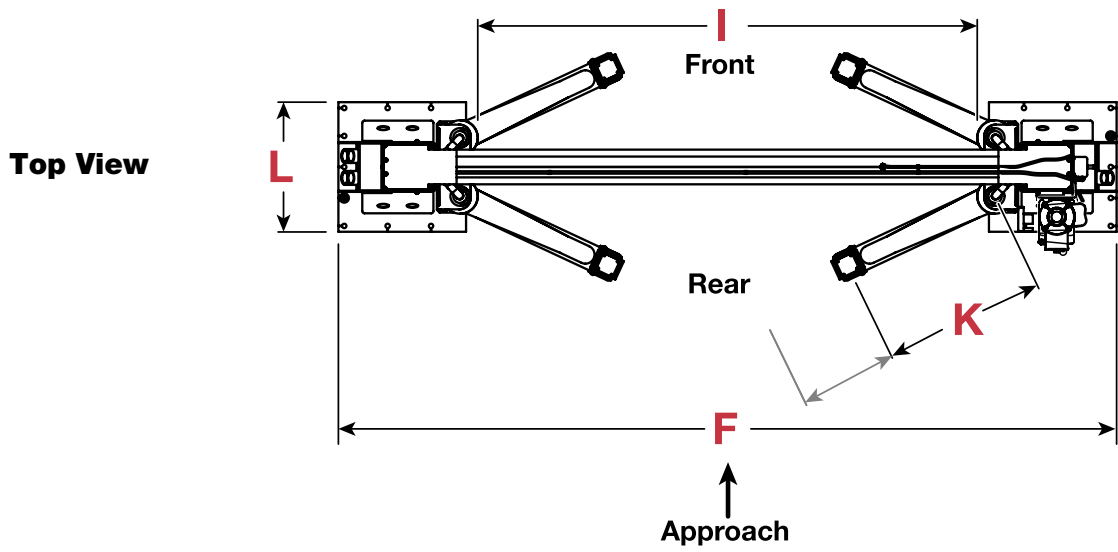

Reference only – do not scale.

Model	16AP	16AP-192
Lifting Capacity	16,000 lbs. (7,257 kg)	
Max. Capacity — Front Axle	8,000 lbs. (3,629 kg)	
Max. Capacity — Rear Axle	8,000 lbs. (3,629 kg)	
Max. load per Lift Arm	4,000 lbs. (2,268 kg)	
A – Max. Rise (no Safety Lock engaged) ¹	76 in. (1,933 mm)	
B1 – Max. Lifting Height w/ Pad (Top Lock) ²	82.25 in. (2,089 mm)	
B2 – Max. Lifting Height w/Pad (no Lock) ³	82.75 in. (2102 mm)	
C – Max. Lifting Height w/Adapters (Top Lock) ⁴	89.75 in. (2,277 mm)	
D – Min. Height w/ Pad	7.75 in. (198 mm)	
E – Overall Height	169 in. (4,294 mm)	193 in. (4,904 mm)
F – Width Overall	168 in. (4,267 mm)	
G – Outside Posts	149 in. (3,785 mm)	
H – Inside Posts	126 in. (3,199 mm)	
I – Drive-Thru Width	107.75 in. (2,742 mm)	
J – Floor to Top Switch	163 in. (4,128 mm)	186.5 in. (4,738 mm)
K – Lift Arm Reach (min. – max.) ⁵	36 in. to 65 in. (931 mm to 1,651 mm)	
L – Base Plate Width	28 in. (710 mm)	
M – Post to Base Plate	9.5 in. (241 mm)	
Time to Full Rise	≈ 79 seconds	
Motor Power Consumption Range (typical) ⁶	208 to 230 VAC, 50/60 Hz, 1 Ph, 5 HP, Approx. 23 Amps	
Hydraulic Fluid Required	6.3 gallons (23.8 Liters)	
Sound Pressure	<70 dB	
Operating Pressure at Maximum Load	2,170 psi	

¹ Max. Rise is measured to the bottom of the Lift Arms at maximum lift extension, no Safety Lock engaged.

² Maximum Lifting Height is measured to the top of the Pad while engaged on the Top Safety Lock.

³ Max Lifting Height is measured to the top of the Pad at maximum vertical travel. Safety Locks not engaged.

⁴ Max. Lifting Height w/Adapters is measured to the top of the Lift Pad with medium (63 mm) and tall (125 mm) adapters installed while engaged on the Top Safety Lock.

⁵ Lift Arm length measured from the Lift Arm pivot point to the Lift Cradle Pad's center pin.

⁶ Special Voltages available.

Specifications subject to change without notice.

Model	20AP	20AP-192
Lifting Capacity	20,000 lbs. (9,072 kg)	
Max. Capacity — Front Axle	10,000 lbs. (4,536 kg)	
Max. Capacity — Rear Axle	10,000 lbs. (4,536 kg)	
Max. load per Lift Arm	5,000 lbs. (2,268 kg)	
A – Max. Rise (no Safety Lock engaged) ¹	76.5 in. (1,943 mm)	
B1 – Max. Lifting Height w/ Pad (Top Lock) ²	82.75 in. (2,103 mm)	
B2 – Max. Lifting Height w/Pad (no Lock) ³	83.25 in. (2,114 mm)	
C – Max. Lifting Height w/Adapters (Top Lock) ⁴	90.25 in. (2,292 mm)	
D – Min. Height w/ Pad	8 in. (206 mm)	
E – Overall Height	169 in. (4,294 mm)	193 in. (4,904 mm)
F – Width Overall	168 in. (4,267 mm)	
G – Outside Posts	149 in. (3,785 mm)	
H – Inside Posts	126 in. (3,199 mm)	
I – Drive-Thru Width	107.75 in. (2,742 mm)	
J – Floor to Top Switch	162.5 in. (4,128 mm)	186.5 in. (4,738 mm)
K – Lift Arm Reach (min. – max.) ⁵	35 in. to 62 in. (893 mm to 1,575 mm)	
L – Base Plate Width	28 in. (710 mm)	
M – Post to Base Plate	9.5 in. (241 mm)	
Time to Full Rise	≈ 79 seconds	
Motor Power Consumption Range (typical) ⁶	208 to 230 VAC, 50/60 Hz, 1 Ph, 5 HP, Approx. 23 Amps	
Hydraulic Fluid Required	6.3 gallons (23.8 Liters)	
Sound Pressure	Lift produces less than 85 dB when in operation.	
Operating Pressure at Maximum Load	2,647 psi	

¹ Max. Rise is measured to the bottom of the Lift Arms at maximum lift extension, no Safety Lock engaged.

² Maximum Lifting Height is measured to the top of the Pad while engaged on the Top Safety Lock.

³ Max Lifting Height is measured to the top of the Pad at maximum vertical travel. Safety Locks not engaged.

⁴ Max. Lifting Height w/Adapters is measured to the top of the Lift Pad with medium (63 mm) and tall (125 mm) adapters installed while engaged on the Top Safety Lock.

⁵ Lift Arms measured from the Lift Arm pivot point to the Lift Cradle Pad's center pin.

⁶ Special Voltages available.

Specifications subject to change without notice.

Installation Checklist

Following are the steps needed to install the 16AP or 20AP Series Two-Post Lifts; perform them in this order.

- 1. Review the Safety Rules.
- 2. Make sure you have the necessary tools.
- 3. Plan for Electrical Work.
- 4. Review the Installation Orientation.
- 5. Review Clearances around the Lift.
- 6. Select the Installation Location.
- 8. Install the Safety Assemblies and position the Safety Cable.
- 9. Move the Equalizing Cables into position.
- 10. Verify the Cylinder Clamps are in position.
- 11. Add Post Extension (16AP-192 or 20AP-192 Models only).
- 12. Learn about Hydraulic Fluid contamination.
- 13. Learn about Liquid Thread Sealant.
- 14. Routing the Hydraulic Hoses.
- 15. Create Chalk Line Guides for the Posts.
- 16. Anchor the Posts.
- 17. Prepare and install the Overhead Assembly and Safety Shutoff Bar.
- 18. Install the overhead limit switch.
- 19. Complete the Equalizing Cables installation.
- 20. Mount the Power Unit (*but do not connect it to power yet*).
- 21. Route and install the Safety Lock Cable.
- 22. Connect the Hydraulic Hoses.
- 23. Install the Lift Arm Assemblies.
- 24. Install the double threaded rods
- 25. Perform final Leveling.
- 26. Contact the Electrician.
- 27. Wire the overhead limit switch (**Electrician required**).
- 28. Connect the Power Unit (**Electrician required**).
- 29. Install the Power Disconnect Switch (**Electrician required**).
- 30. Install a Thermal Disconnect Switch, if required by local electrical code (**Electrician required**).
- 31. Lubricate the Lift.
- 32. Review the Final Checklist.
- 33. Perform an Operational Test.
- 34. Leave the Manual at the Lift for the Owner/Operator.

Installation

The installation process includes multiple steps. Perform them in the order listed.

⚠ WARNING Use only the factory-supplied parts shipped with your Lift. If you use attachments, accessories, or configuration modifying components that are in the path and/or affect the operation of the equipment, affect the equipment's electrical listing, or affect the intended Vehicle accommodation, and if they are not certified for use with this Lift, then you void the warranty of the Lift as well as compromising the safety of everyone who sets up or uses the Lift.

If you are missing parts, visit [BendPak.com/Support](https://www.bendpak.com/Support), email support@bendpak.com or contact BendPak technical support by phone at **(800) 253-2363** select option 7, then 4.

Online chat is also available at www.bendpak.com click the chat icon.



Reviewing the Safety Rules

When installing a Lift, your safety depends on proper training and thoughtful operation. BendPak recommends referring to the ANSI/ALI ALIS Standard *Safety Requirements for Installation and Service* for more information about safely installing, using, and servicing your Lift.

⚠ WARNING Do not install this equipment unless you have automotive lift installation training. Do not install this equipment without reading and understanding this Manual and the Labels on the unit. Always pay attention. Use appropriate tools and stay clear of moving parts.

⚠ WARNING This Lift includes components that are heavy and awkward to work with. Installation personnel should have knowledge, training, and experience in lifting, rigging, and securing heavy objects. Competent personnel will ensure the components are properly rigged and balanced for lifting.

⚠ WARNING You must always wear appropriate protective equipment during installation: leather gloves, steel-toed work boots, eye protection, back belts, head, and hearing protection.

Gathering Your Tools

You may need some or all of the following tools:

- Rotary hammer drill (or similar)
- 3/4-inch carbide bit (conforming to ANSI B212.15)
- Hammer
- Four-foot level
- Open-end wrench set, SAE, and metric
- Socket and ratchet set, SAE, and metric
- Hex-key wrench set
- Crescent and pipe wrenches
- Crowbar
- Chalk line
- Medium-sized flat screwdriver
- Tape measure, 25 feet or more
- Needle-nose pliers
- Forklift or Shop Crane
- Two 12-foot ladders
- Two sawhorses
- Torque wrench

Prepare for Electrical Work

A licensed Electrician must be available to complete the electrical portion of the installation.

⚠ DANGER All wiring **must** be performed by a licensed Electrician in accordance with applicable local, state, and national electrical codes, as well as state and federal OSHA regulations.

NOTICE Notify your Electrician in advance so they arrive prepared with the items required to connect to the facility's power system, or an appropriate power cord with plug to connect to an appropriate VAC power source, a Power Disconnect Switch, and a Thermal Disconnect Switch (if required by local electrical code). **These items are not supplied with the Lift.**

The Electrician will be required to:

- **Connect to the VAC power source.** The Power Unit is delivered with a pigtail for wiring to a power source. Have your Electrician connect a power cord with plug to the electrical box on the Lift for connection to a power outlet or have them wire it directly into the electrical system at the Lift location. The Lift's Power Unit must be protected by an appropriate circuit breaker.
- **Connect the overhead limit switch wiring to the Power Unit.** The overhead limit switch must be wired to the Power Unit. The required wiring is included with the Lift.
- **Install a Power Disconnect Switch.** A Power Disconnect Switch is used to shut down the Lift in the event of an electrical circuit fault, emergency, or when the Lift is being serviced. Refer to [Installing a Power Disconnect Switch](#) for more information.
- **Install a Thermal Disconnect Switch.** The Power Unit supplied with this Lift **does not** include thermal overload protection. Under NEC 430, UL 201, and CSA C22.2 No. 68 intermittent duty motors are not required to include thermal protection. Local electrical codes may vary, and other requirements may exist that the installing electrician will address, if required. Refer to [Installing a Thermal Disconnect Switch](#) for more information.

Review the Installation Orientation

Keep the following in mind when deciding how to orient the Lift in the facility:

- The first thing to consider is the direction vehicles will be driving into the Lift, called the **Approach**.
 - In most cases there is a driveway on one side of the Lift and a wall on the other side. The driveway is your Approach. This makes the wall side the Front of the Lift and the driveway side the Rear of the Lift.
 - If both sides are open, choose which direction will be the safest for driving vehicles onto the Lift. This is the Approach; the drive-**on** side is the Rear of the Lift and the drive-**off** side is the Front.
- While the Power Unit **must** be installed on the Power Side Post, that power side post may be mounted on either side of the Approach. You can identify the power side post by the mounting bracket to which the Power Unit attaches. Refer to the figures below.

Top View
Power Unit on
Approach Side

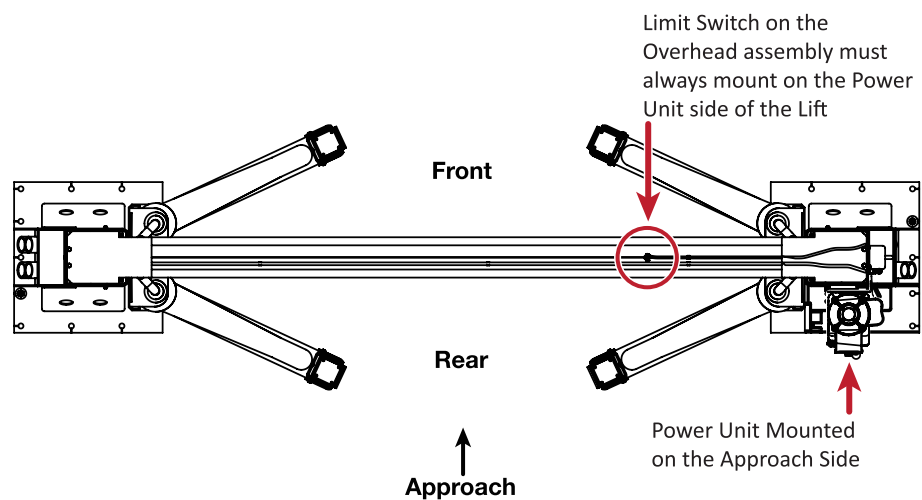

Top View
Power Unit Opposite
the Approach

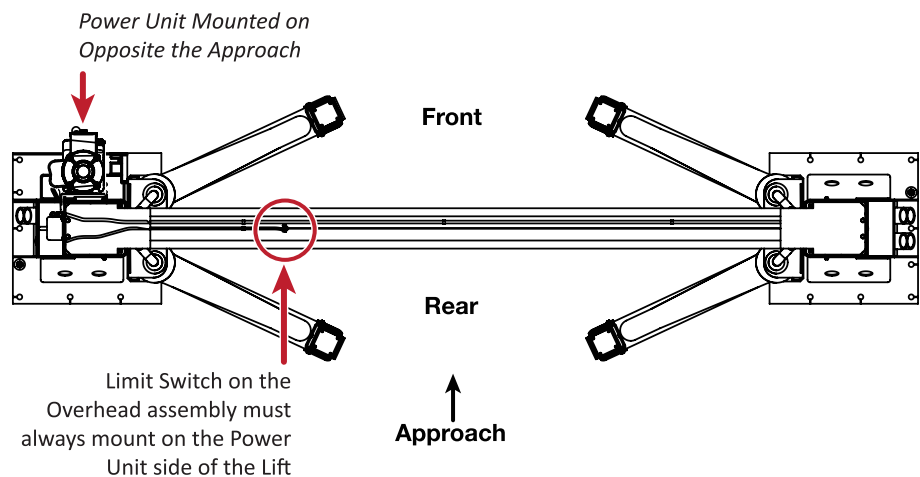

CAUTION

When installing the Overhead Assembly, always orient the assembly to place the overhead limit switch on the Power Unit side of the Lift.

Check Clearances

Clearance around and above the Lift is **required for safety**. Refer to the figures below.

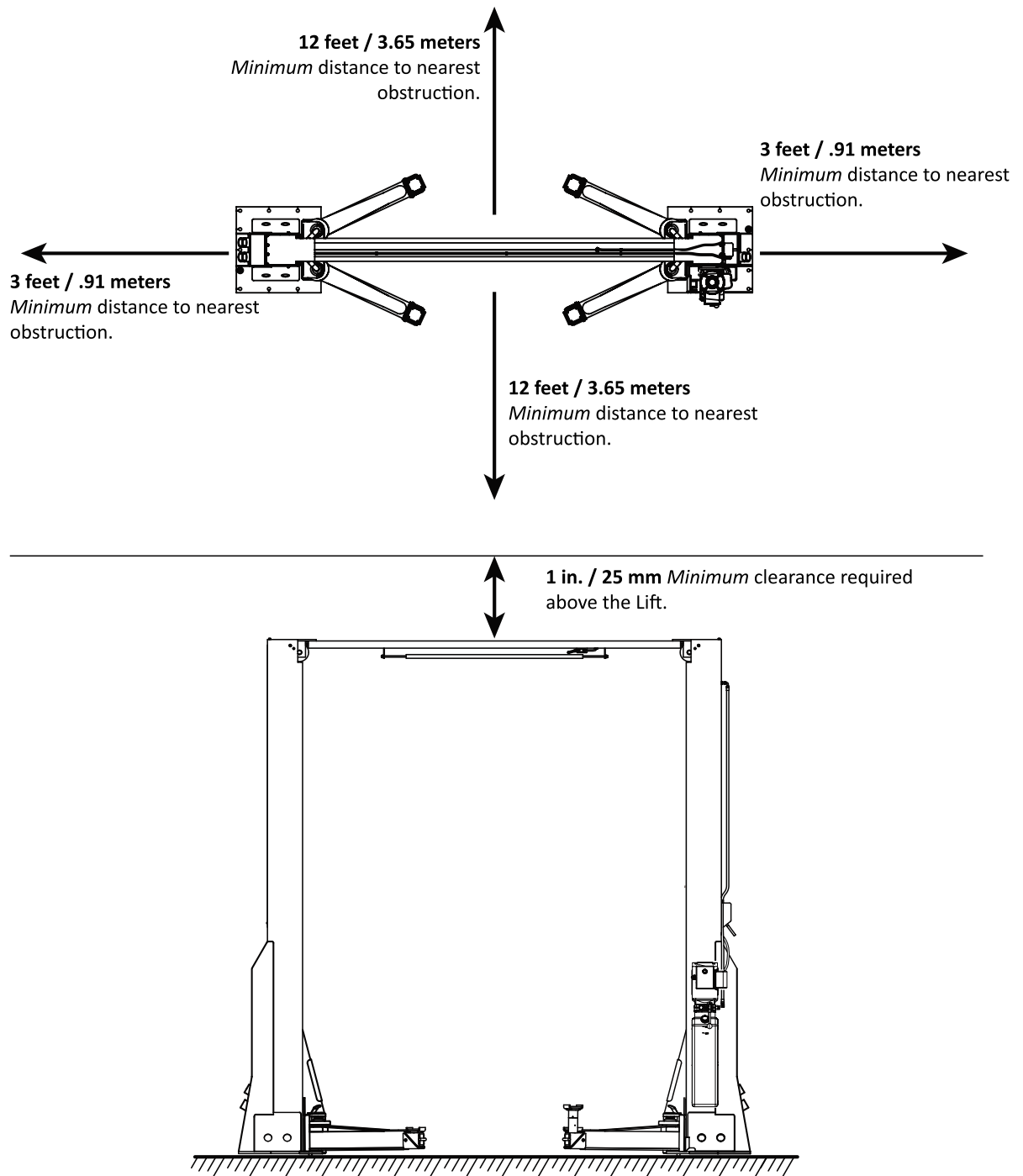

Figures are not to scale. Additional distance may be required in the front and rear of the Lift to allow vehicles to be safely driven in or out from these directions.

Select a Location

When selecting the location for your Lift, consider the following:

 **DANGER** **Risk of explosion:** This equipment has internal arcing or parts that may spark and should not be exposed to flammable vapors. The Power Unit's motor should not be located in a recessed area or below floor level. Always install at least 18 in. (457 mm) above the floor. Never expose the motor to rain or other damp environments; damage to the motor caused by water is not covered by the warranty.

- **Architectural plans.** Consult the architectural plans for the desired location. Make sure there are no contradictions between what is planned for the Lift installation and what the plans and building codes will allow.
- **Available space.** Make sure there is enough space for the Lift: front, back, sides, and **above**. Refer to **Specifications** for exact measurements. Check for overhead obstructions such as building supports, heaters, lights, electrical lines, low ceilings, and so on.
- **Power.** You need an appropriate VAC power source for the Lift's Power Unit.
- **Outdoor installations.** 16AP and 20AP Series Two-Post Lifts are approved for indoor installation and use only. **Outdoor installation is prohibited.**
- **Floor.** Only install the Lift on a flat, concrete floor; do not install on asphalt or any other surface. The surface must be level; do not install if the surface has a slope greater than or equal to 3°.

 **WARNING** Installing your Lift on a surface with more than three degrees of slope could lead to injury or even death. Only install your Lift on a level floor (defined as no more than 3/8 of an inch (9.5 mm) difference over the installation area). If your floor is not level, consider making the floor level or create a new concrete pour or choose a different location.

- **Concrete specifications. The concrete must be steel reinforced, a minimum 8 inches (203 mm) thick, steel reinforced, with a minimum compressive strength of 3,000 psi, and cured for a minimum of 28 days.** Do not install the Lift on cracked or defective concrete. Anchor Bolts must be more than 6 inches (150 mm) from cracks, expansion joints, walls, or any other inconsistencies in the concrete.

 **CAUTION** BendPak Lifts are supplied with installation instructions and concrete anchors that meet the criteria set by the latest version of the American National Standard in Automotive Lifts – Safety Requirements for Construction, Testing, and Validation in., ANSI/ALI ALCTV. Consult with an expert for any special regional structural and/or seismic anchoring requirements specified by any other agencies and/or codes such as the Uniform Building Code (UBC) and/or International Building Code (IBC).

- **Never drill or cut into a Post-Tension Concrete Foundation!** Check your floor for the possibility of it being a post-tension slab. In this case, contact the building architect **before** drilling. Cutting a Post-Tensioned Cable can result in severe injury or death. Post-Tensioned Foundations are compressed by high-strength steel tendons after the concrete has cured. Pressures on the steel tendons can be quite high. A qualified technician is required to identify cable locations prior to cutting or drilling. Post-Tension Slabs in many homes are indicated by a warning stamped into the concrete, often found near the garage door. Older structures may have a plastic or paper sign

 **POST-TENSION SLAB
DO NOT CUT OR CORE**

fastened to the wall. If there are no signs indicating a Post-Tension Slab, undertake a careful examination of the exterior of the slab looking for small circular patching areas about 1.5 in. to 3 in. (38 to 76 mm) in diameter, typically 2 to 4-feet (609 to 1220 mm) apart. These patches indicate the ends of the Post-Tension Cables. Another source of information is your local department of Building and Safety. Building and Safety may retrieve the structure plans to determine if the building has a Post-Tensioned Slab.

 **WARNING** Cutting through a post-tensioned cable can result in injury or death. Do not drill into a post-tension slab unless the building architect confirms you are **not** going to hit tensioned steel, or it has been located using ground penetrating radar. **If a colored sheath comes up while drilling, stop drilling immediately!**

- **Unloading the components.** Unload the Lift components as close to the installation location as possible. The Lift includes several heavy components. Unloading close to the installation area will ease the installation task.

 **WARNING** Some Lift components are very heavy; if handled incorrectly, they can damage materials like tile, sandstone, and brick. Personnel involved should be trained and experienced in rigging and lifting heavy components. Try to handle the Lift components just twice: once when delivered and once when moved into position. You must have a Forklift or Shop Crane to move some of the Lift components into position. **Use care when moving Lift components.**

Install the Safety Assemblies and Position the Safety Lock Cable

Leave both lift posts flat on the ground and positioned to allow access to the inside of the post for the safety lock installation. This procedure will leave the safety cable coiled at the top of the off side post, ready for routing after the Posts are standing. This position will also allow the initial placement of the equalizing cables.

16AP and 20AP Series Lifts have two Safety Assemblies: one on the power side post and the other on the off side post at the same height.

The two safety assemblies engage the lift head and prevent it from lowering. The safety release mechanism allows the lift head to move past the safety locks and lower to the ground. The safety assemblies must be disengaged **at the same time** so that both lift heads lower together. To accomplish this, the safety assemblies are connected to each other via a safety lock cable, which is routed through the lift posts and the overhead assembly. The following illustrations display the off side and power side safety mechanisms.

Off Side Safety: Similar to the power side Safety but does not have a Safety Lock Release Handle.

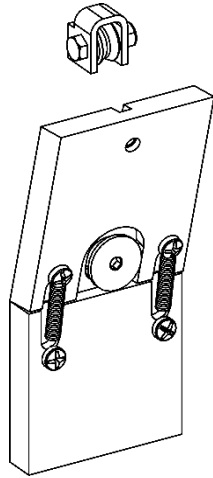

Power Side Safety: The power side safety includes a safety lock release handle and spring, which is pushed down by the operator and used to disengage the safety locks when lowering the Lift.

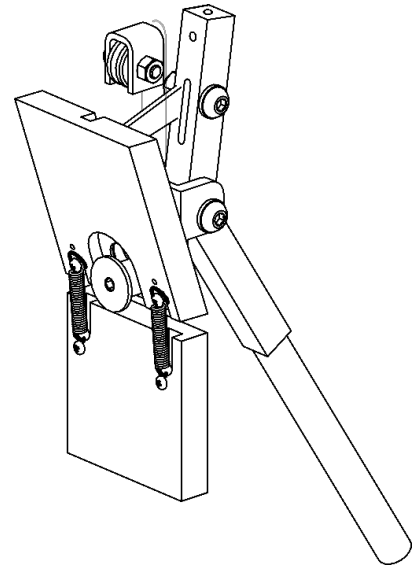

To assemble and install the two safety assemblies and pre-position the safety release cable:

1. Position both posts either flat on the ground or elevated on a sawhorse or similar device. The **inside** of the posts must be accessible, facing up.
2. Slide the lift heads away from the bottom of both posts. Move them far enough to clear the safety lock and provide room to work.

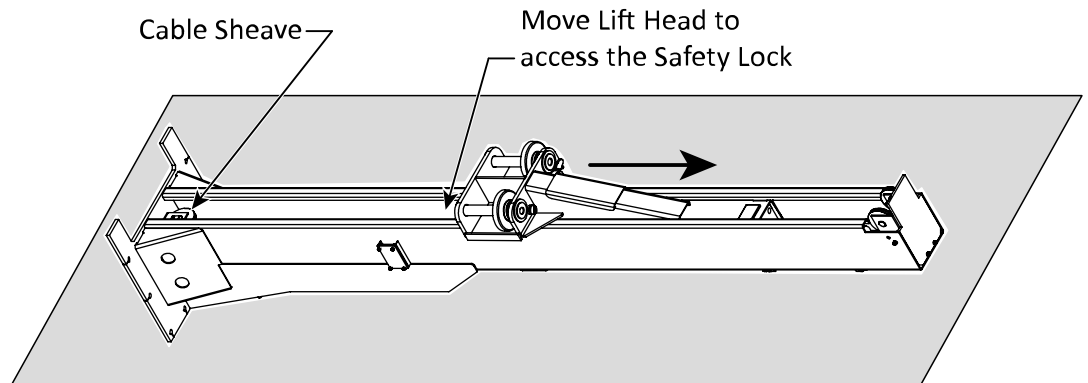
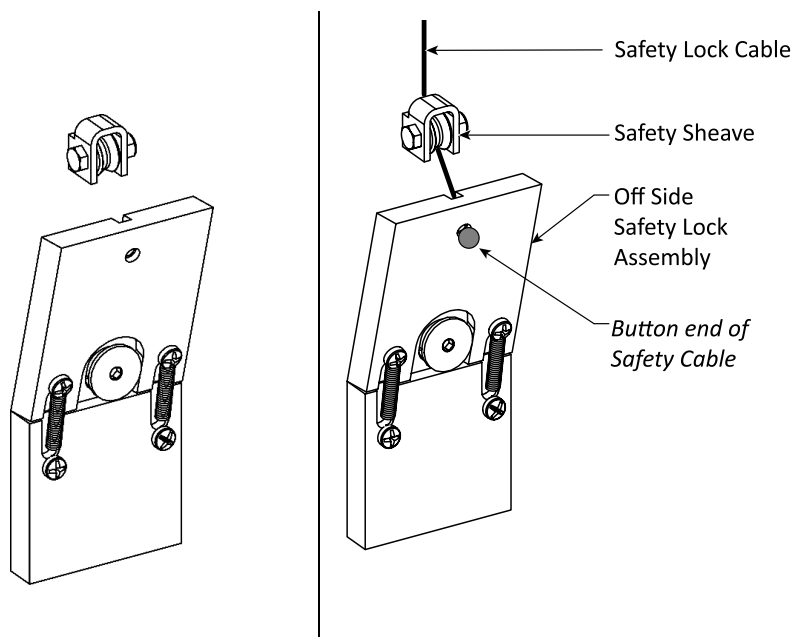

Figure above not to scale. Components removed for clarity.

- Retrieve the safety lock cable from the parts box. This is a long, thin wire rope cable with a button swaged onto one end and nothing on the other end. Thread the cable through the Offside Safety Block as shown below. The length of the safety cable varies based on the Lift model, refer to the table below.

Model	Part Number	Safety Cable Dia. and Length
16AP 20AP	5595759	Ø1.8 x 8,850 mm
16AP-192 20AP-192	5595761	Ø1.8 x 10,070 mm

- Thread the remainder of the Safety Lock Cable under the Safety Cable Sheave and the Lift Head, then up to the top of the off side post. **Coil the cable and secure with tape or equivalent at the top of the off side lift post until called for later in the assembly.**
- Move to the power side post**, Attach the Safety Pivot Holder (5700404) to the power side post, as depicted in step 6 below.
- On the back side of the Power Post connect the pivot pin, the safety pivot holder and the safety release handle using the fasteners depicted below.



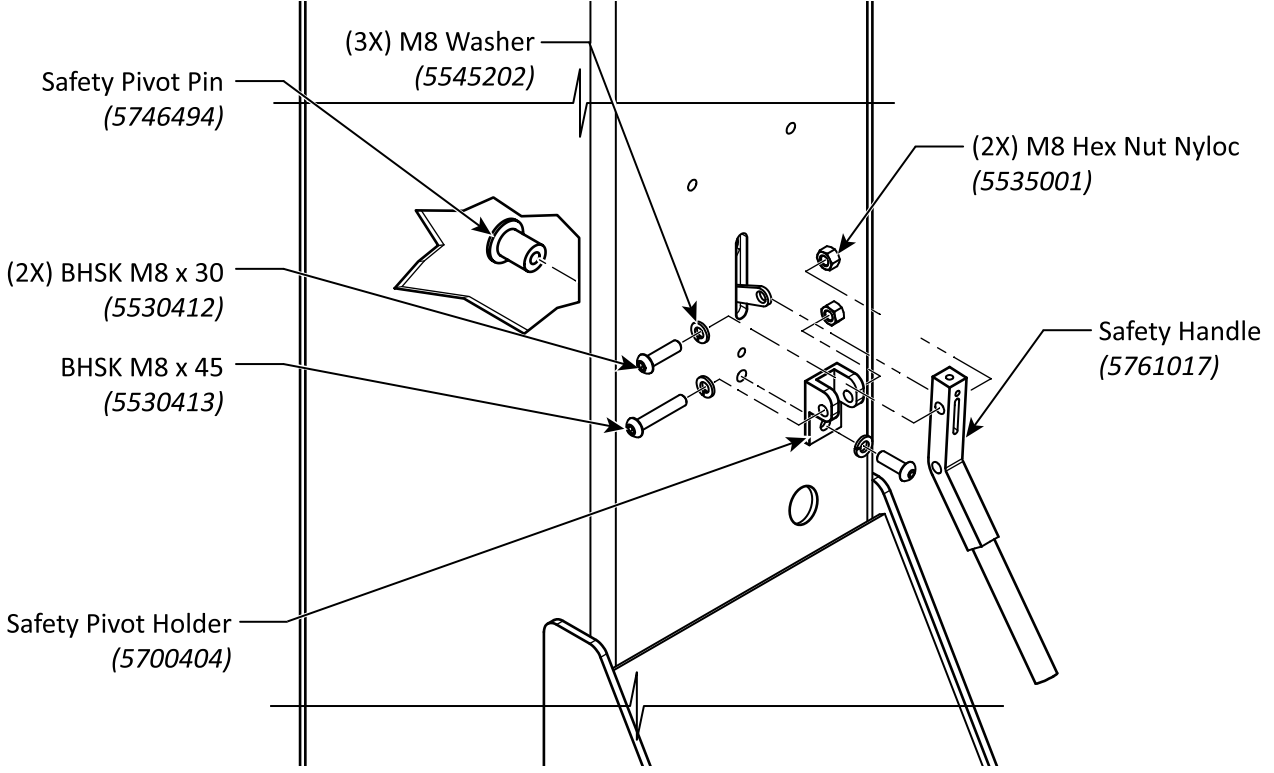
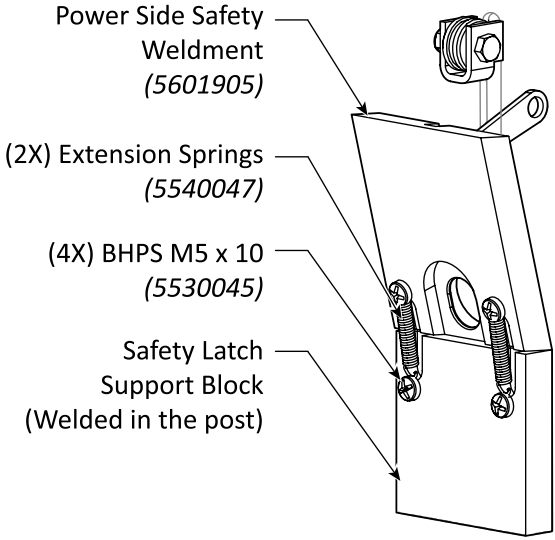

Reference only – do not scale.

Move the Equalizing Cables into Position

BendPak recommends placing the equalizing cables into position **before** standing the posts up. Loop the excess cable at the top of the post secured with a zip tie or tape.

NOTICE The two equalizing cables are the same length.

CAUTION BendPak recommends wearing safety gloves when handling the Equalizing Cables.

The figure below provides an overview of the Equalizer Cable routed into position and coiled at the top of the post.

IMPORTANT To prevent the cable button end from working free of the Lift Head while raising the Post, use a pair of locking vise grips to grab and hold the cable. Lock the vise grips on the cable at the top of the lift head to temporarily secure the cable from movement.

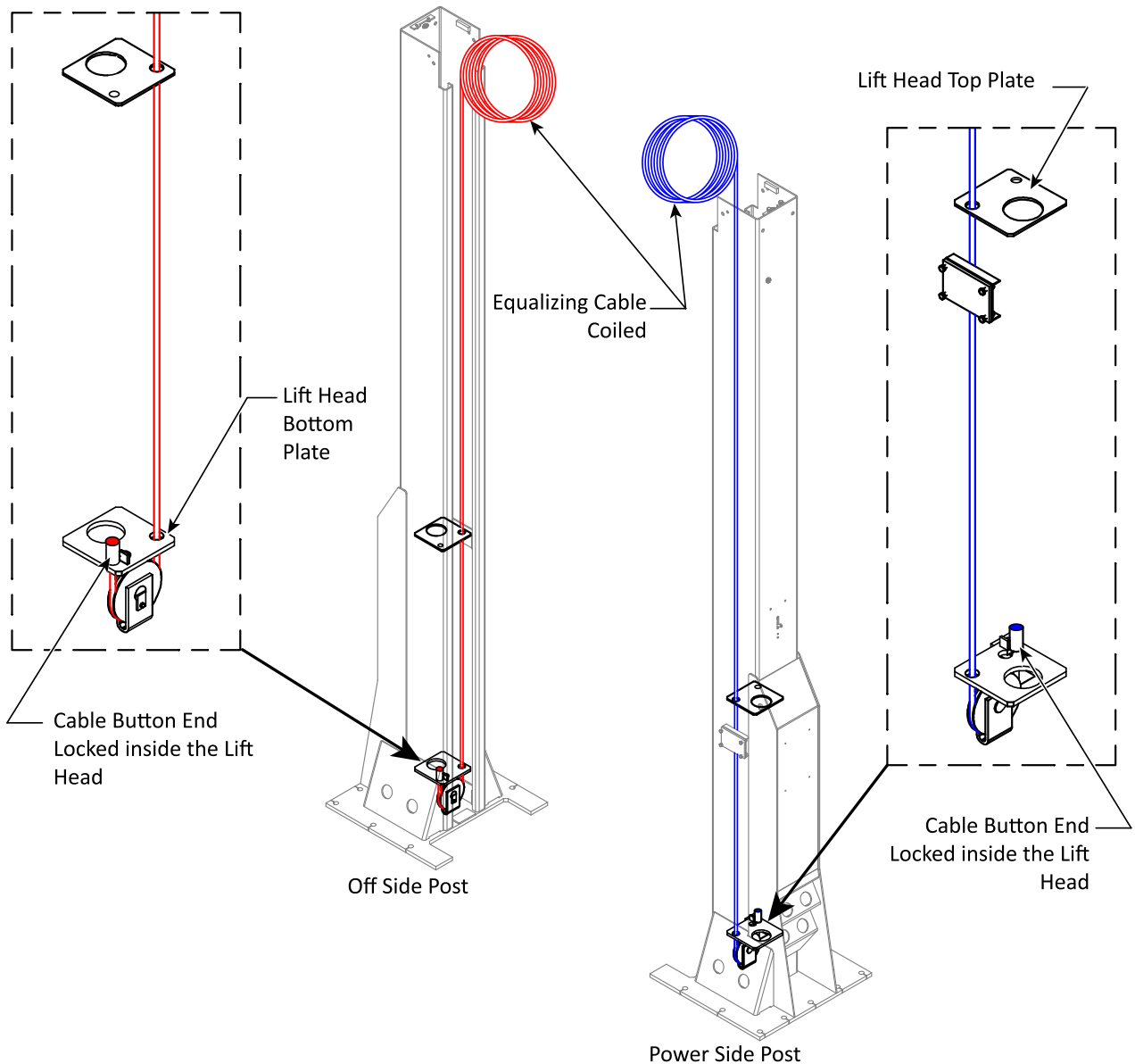

Not to scale, components removed for clarity.

To put the Equalizing Cables into position:

1. Position both posts either flat on the ground or elevated on a sawhorse or equivalent. The **insides** of the posts must be accessible, facing up.

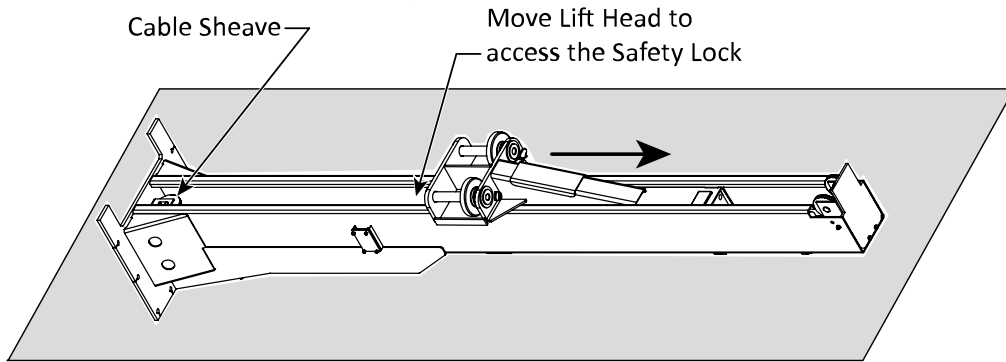

2. Slide the lift heads away from the bottom of both posts. Far enough to provide access to the bottom of the lift head and the cable sheave.
3. Retrieve the two Equalizing Cables for your Lift. Each model has a specific Equalizing Cable length as noted in the table below.

Model	Part Number	Equalizing Cable Assembly Dia. and Length
16AP / 20AP	5595840	Ø12 x 10,633 mm
16AP-192 / 20AP-192	5595617	Ø12 x 11,849 mm

4. Remove the cable sheave from the bottom of both posts.

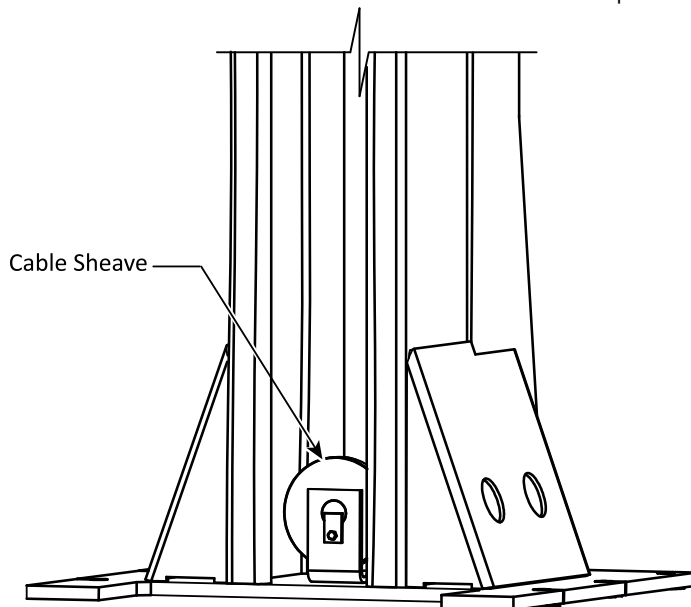
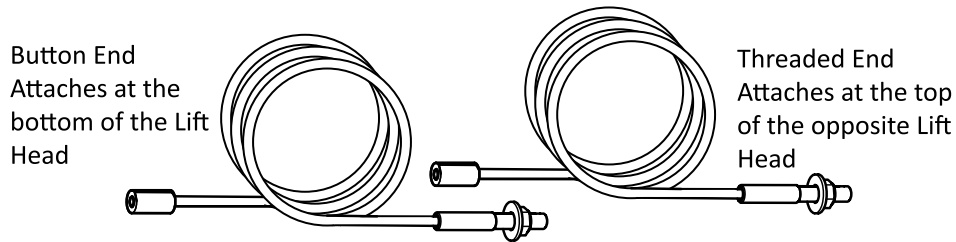

Figure above details the cable sheave near the bottom of the post. Reference only – do not scale.

NOTICE Keep the post sheave, sheave pin, and bolt nearby where they will not be lost or damaged.

- Retrieve an equalizing cable and locate the button end.



- Push the button end up through the bottom plate of the lift head up towards the cable button stop, then push the button end into the slot in the stop.

Important

If you are having problems getting the button end into the slot, try pushing the button end past the button stop and out the hole at the top of the lift head; now, move the equalizing cable around to work it into the Slot. Once the cable is in the slot, pull back on the other end of the cable to slide the button end into the slot. Try to keep the Cable taut until the Equalizing Cable is connected at the other end, later in the installation. Note that it can be difficult to get the cable back into the slot if it comes out.

- Route the equalizing cable down to where the post sheave was and then up again towards the top of the post.
- Lubricate the cable sheave pin and bearing with red lithium grease, then replace the cable sheave, making sure the equalizing cable is routed under it and seated in the sheave.
- Push the threaded end of the equalizing cable through the lift head and out the hole at the top of the lift head. Refer to the figures below.

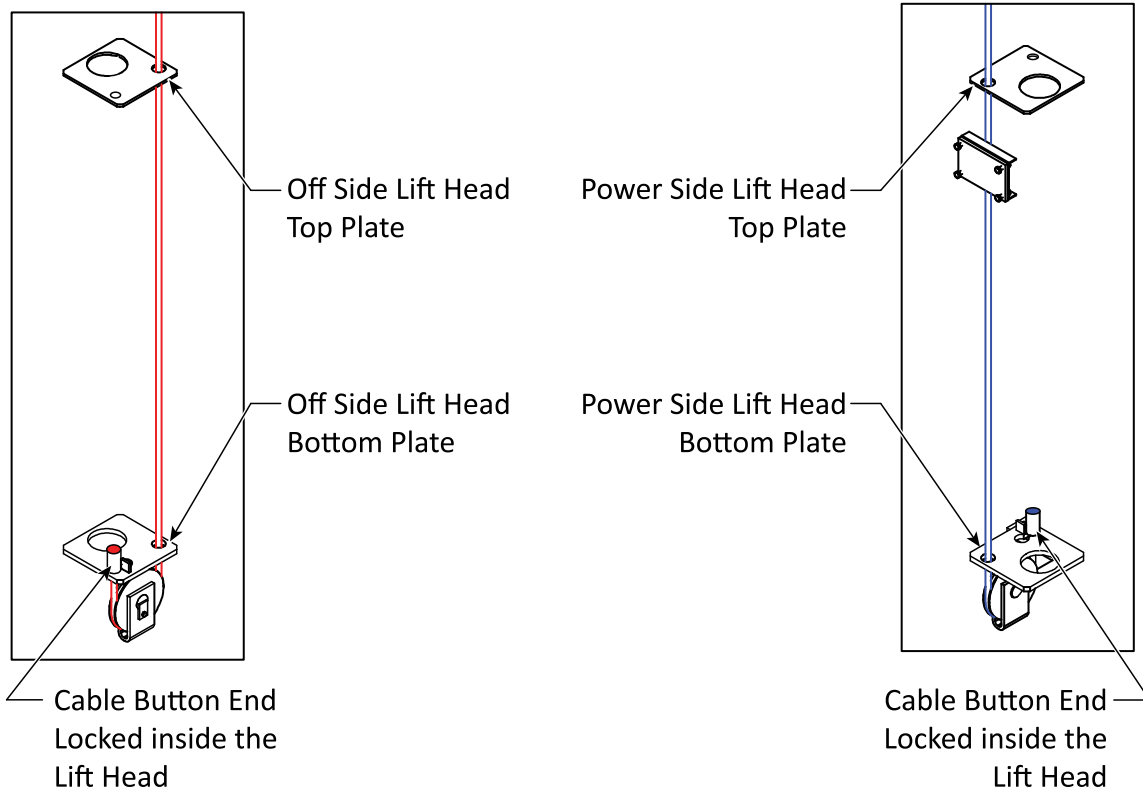

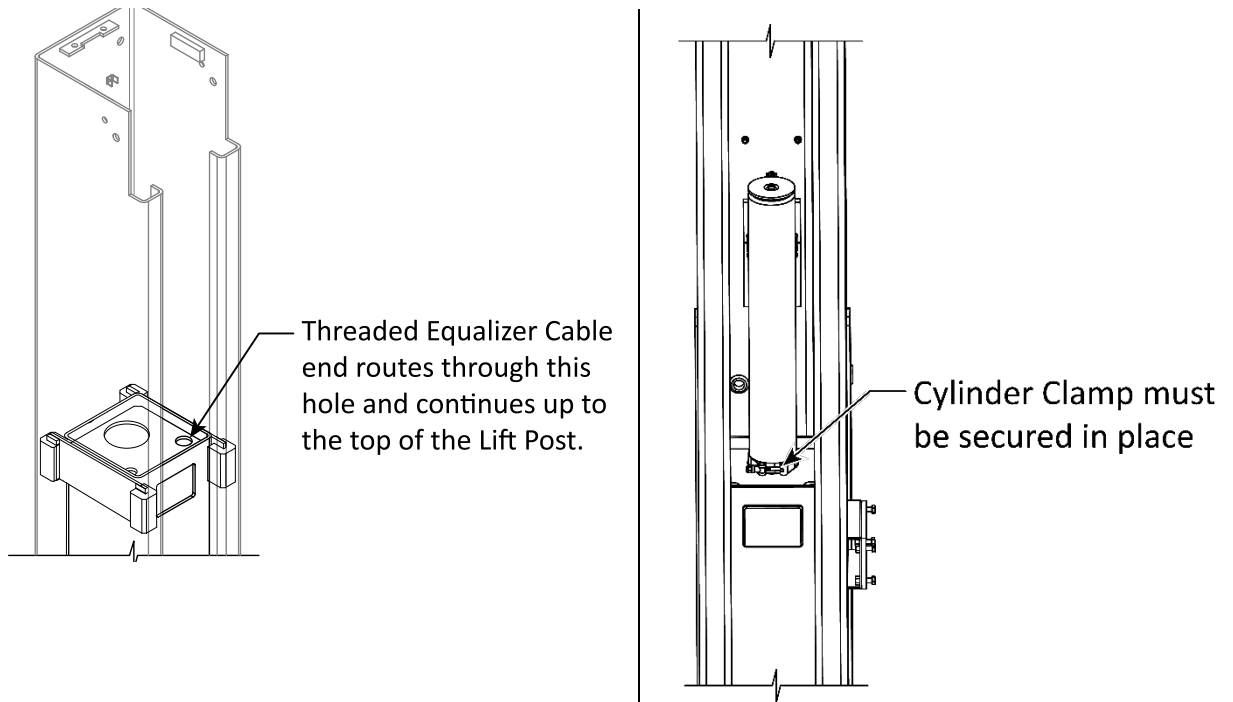

10. Verify the Cylinder Clamps are in place and secured on the hydraulic cylinders above the lift head.

⚠ WARNING Cylinder clamps **must** be positioned at the top of the lift head and secured. **Do not operate the Lift if the cylinder clamps are not secured on the hydraulic cylinders.**

11. Move both lift heads back down to the bottom of each post.

12. Coil up and bind the remainder of the cable at the top of the lift post temporarily.

Post Extensions 16AP-192 and 20AP-192 only

Model numbers **16AP-192** and **20AP-192** are supplied with post extensions that increase the height of the posts and allow the Lift to raise taller vehicles.

The post extensions are slipped over the top of both lift posts and then bolted into place.

Model	Part Number	Description
16AP-192	5216204	Post Extension Assembly
20AP-192	5216204	Post Extension Assembly

To install the Post Extensions:

1. Locate the two post extensions and the 4 Hex Head Bolts, 8 Flat Washers, 4 Split-Lock Washers, and 4 Hex Nuts. Reference the illustration below.
2. Slide one of the post extensions over the top of one of the lift posts.
The opening in the post extension faces the inside of the Lift.
3. Secure the extension to the lift post, using the hardware listed in the illustration below.
4. Slide the last post extension on the remaining lift post and secure it the same manner.

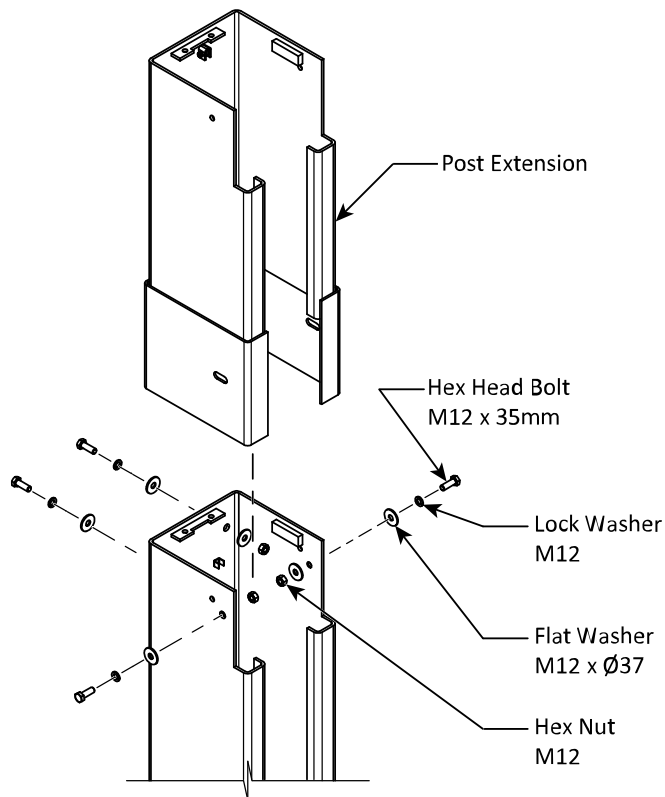



IMPORTANT! PLEASE READ NOW



Hydraulic Fluid Contamination poses a serious issue for your Lift; contaminants such as water, dirt, or other debris can migrate into the Hydraulic Hoses and Fittings on the Lift, making your new Lift inoperable and unusable.

Your Lift is shipped with clean components; however, BendPak strongly recommends that you take secondary precautions and clean all Hydraulic Hoses and Fittings prior to making connections. It is better and less costly to take these extra steps now so that you do not need to take your Lift out of service later to fix issues that could have been prevented at the time of installation.

There are several methods that may be used to clean Hydraulic Hoses and Fittings:

- **Compressed Air.** Use an air compressor to blow out contaminants from each Hydraulic Hose and Fitting prior to installation. Clean, dry air is preferred. Wear ANSI-approved eye protection (safety glasses, goggles, or face shield) when using compressed air for cleaning. Never point an air hose nozzle at any part of your body or any other person.
- **Fluid Flushing.** If the Hydraulic Fluid is clean and compatible with the system fluid, you can flush Hoses and Fittings to create turbulent flow and remove particulates. Always ensure that the fluid itself is contaminant-free.

Some additional steps that will help keep the Hydraulic Fluid clean:

- **Remove old thread seal tape.** Some ports on the Hydraulic Cylinders are shipped with temporary plugs secured with thread seal tape, so make sure to thoroughly remove any leftover thread seal tape that may inadvertently enter the Hydraulic System.
- **Use a liquid thread sealant only.** Liquid thread sealant (Loctite™ 5452 or similar) is recommended. Do not use thread seal tape on any fitting. Liquid thread sealant is recommended for NPT connections, fine for JIC connections, but *not* necessary for O-ring (ORB) connections.
- **Always use clean equipment.** If you use a dirty bucket or funnel to transfer the Hydraulic Fluid into the Hydraulic Fluid Reservoir, the contaminants will likely be introduced into the Fluid. When using cleaning rags, use a lint-free rag.
- **Proper storage.** Keep the Hydraulic Fluid sealed in its container until ready for use; store the Fluid in a clean, dry, and cool area.
- **Cover the Hoses and Fittings.** Before installation, do not leave the ends of the Fittings exposed; the same applies for the Hydraulic Hoses. As a rule, keep the Hydraulic Hoses and Fittings capped and in a clean area until ready for use.
- **Filter the new Hydraulic Fluid.** Just because it is new does not necessarily mean it is *clean*. Use an offline filtration cart or kidney loop system to make sure the Hydraulic Fluid is clean before being transferred into the Hydraulic Fluid Reservoir (even using a heavy-duty nylon mesh screen is better than trusting what is left at the bottom of the barrel).
- **Avoid mixing different types of Hydraulic Fluid.** If Hydraulic Fluid needs to be replaced, make sure to flush the Hydraulic System of the old Hydraulic Fluid before you add the replacement Fluid; do not mix the two together.

About Thread Sealants

Liquid Thread Sealant lubricates and fills the gaps between the Fitting threads and leaves no residue that could contaminate the Hydraulic Fluid.

Other types of Thread Sealants (like Teflon Tape) can shred during installation or removal and eventually enter the Hydraulic System.

Use the Thread Sealant only on NPT fittings.

Apply the thread sealant when the ambient temperature is between +46.5°F to +70°F (+8°C to 21°C).

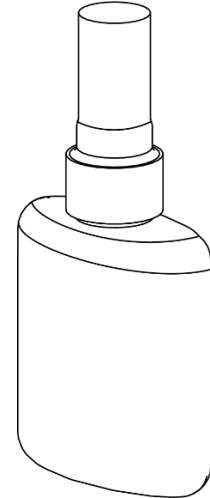

To apply Thread Sealant:

1. Make sure the fittings and connectors are clean and dry.
If adding Thread Sealant to a fitting or connector that has already been used with a different sealant, use a wire brush to thoroughly remove the old sealant before adding more.
2. Skipping the first thread, apply a small amount of thread sealant to the next four threads of the fitting.

⚠ WARNING Always wear the proper protective equipment when handling thread sealant.

You only need a small amount, the sealant spreads to the other threads as it is tightened into place.

Any excess liquid will be pushed out when the fitting is tightened; use a rag to remove any excess.

3. Tighten the Fitting into the connector; do **not** over tighten the Fitting.
4. Allow the **24-hour** manufacturer-recommended curing time before pressurizing the system.

Identifying Hydraulic Fittings

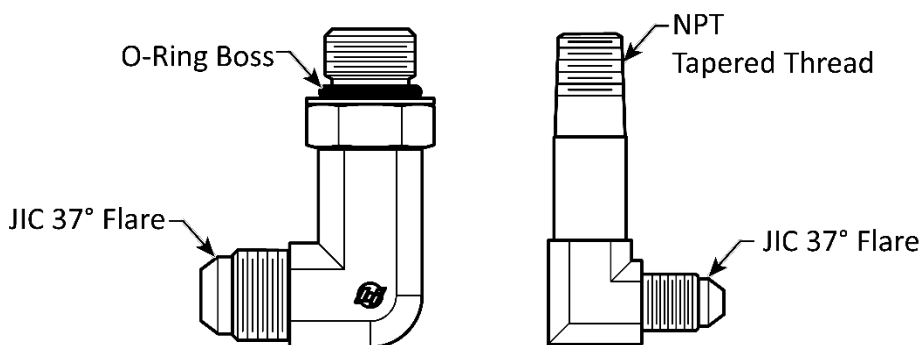

Joint Industry Council (JIC)

National Pipe Thread (NPT)

Route the Hydraulic Hoses

Preposition some hydraulic components **before** standing up the posts. This section will focus on making the connections on each post and coiling the hoses at the top of the post.

All 16AP and 20AP Series Lifts use three Hydraulic Hoses (shown in the illustration below):

Hose A varies based on the length required.

Lift Model	16AP 20AP	16AP-192 20AP-192
Hose A	5570304 Ø6.35 x 7,975 mm	5570303 Ø6.35 x 9,195 mm
Hose B	5570238 Ø6.4 x 3,870 mm	
Hose C	5570290 Ø10 x 2,790 mm	

All hydraulic hoses and fitting locations are detailed in the figure below.

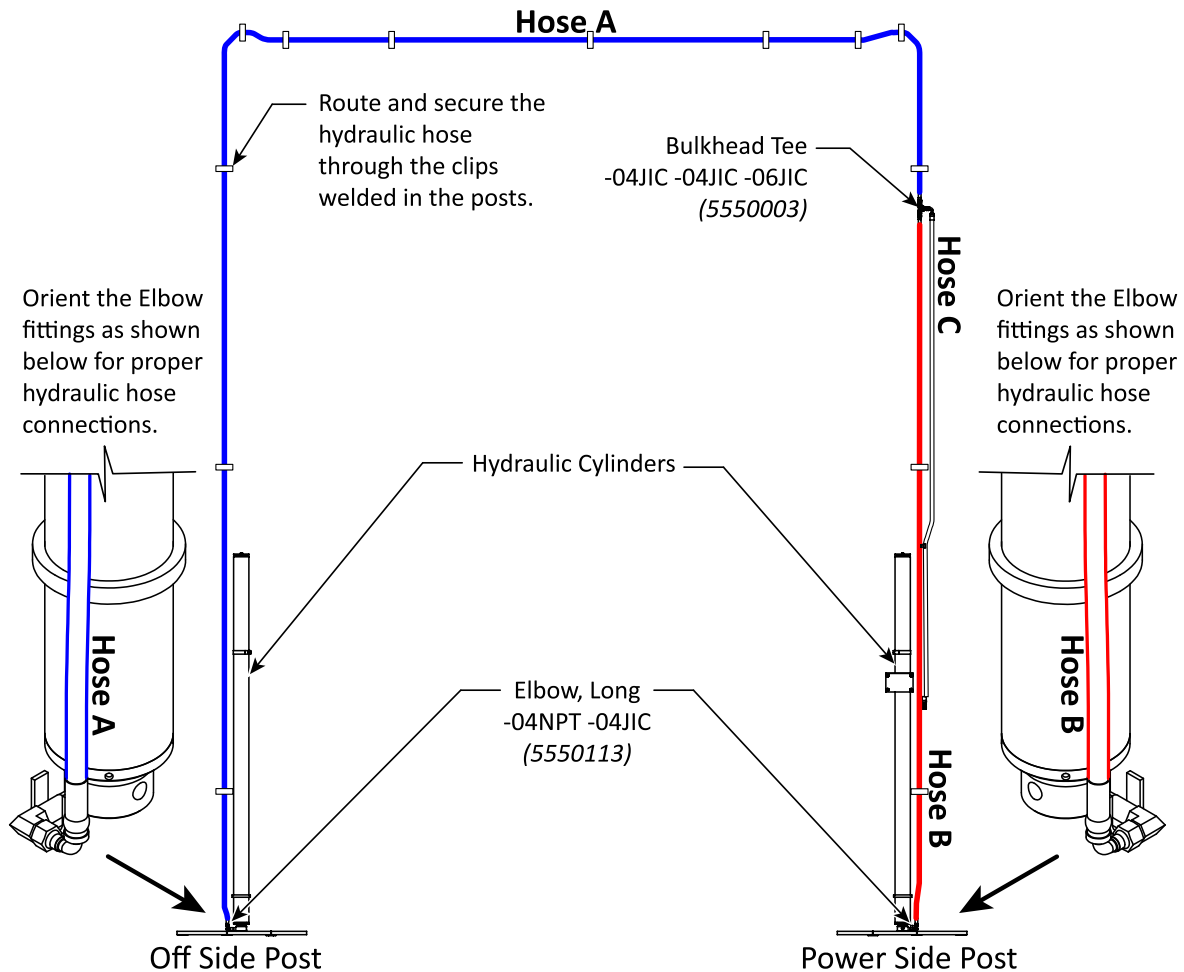

Components removed for clarity.

To position the Hydraulic Hoses:

1. Retrieve the three hydraulic hoses and required fittings: two long elbow fittings (5550113), and one bulkhead tee fitting (5550003).

NOTICE The power unit elbow O-ring fitting (5550183) will be installed later in the process.

2. Retrieve the bulkhead tee fitting (5550003). Remove and retain the panel nut from the larger -06 side of the tee fitting. Push the -06 fitting side through the opening near the top in the power side post. Refer to the figure below. Orient the fitting so that the -04 fittings are pointing to the top and bottom of the post. Tighten the jam nut on the **outside** of the power side post to hold the bulkhead tee fitting in place.

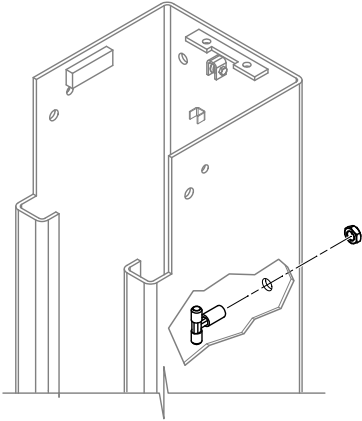

3. **Switching to the bottom of the power side post**, remove the shipping plug from the port on the bottom of the hydraulic cylinder.

Important Keep a rag nearby in case some fluid leaks out of the port when you remove the shipping plug.

4. Apply thread sealant to the male NPT threads one of the two long elbow fittings (5550113). Thread this fitting into the cylinder port; tighten the fitting appropriately.

NOTICE Orient the JIC end of the fitting toward the side of the post with the hose clips. **Use liquid thread sealant on the NPT male threads only.**

5. Turn the cylinder so that the elbow hydraulic fitting is accessible from the bottom rear side of the power side post.

NOTICE When routing hydraulic hoses through the post, place them into the nearby clips and lightly crimp the Clips together along the side of each post. When all hydraulic hoses have been installed, go back and fully crimp all the clips. Take care not to damage the hose with tools or excessive force.

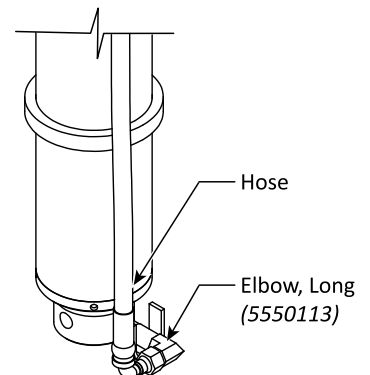

6. Retrieve Hose B and connect the straight end to the bottom of the tee fitting, then tighten securely.
7. Push the 90° elbow end of hose B down to the bottom of the power side post and connect it to the JIC end of the elbow hydraulic fitting; tighten securely.
8. **Switching to the Off Side Post**, connect the other elbow fitting (5550113) to the hydraulic port at the bottom of the hydraulic cylinder.

9. Tighten the elbow fitting securely; make sure to leave the unconnected end of the fitting pointing towards the hose clip side of the post.
10. Retrieve the long hydraulic hose, push the 90° elbow end down through the post, then connect to the elbow fitting (5550113) and tighten securely.

Secure the Hydraulic Hose using the Clips in the post.

11. Carefully coil up and bind the remainder of the Long Hydraulic Hose and leave it resting on top of the off side post until later in the installation.

Hose A should now be connected to the bottom of the hydraulic cylinder in the offside post, with the remainder of the hydraulic hose coiled at the top of the off side post. It will be connected to the rest of the hydraulic system later in the installation procedure. The Power side post should have the B and C hoses connected to the bulkhead tee. Refer to the figure below.

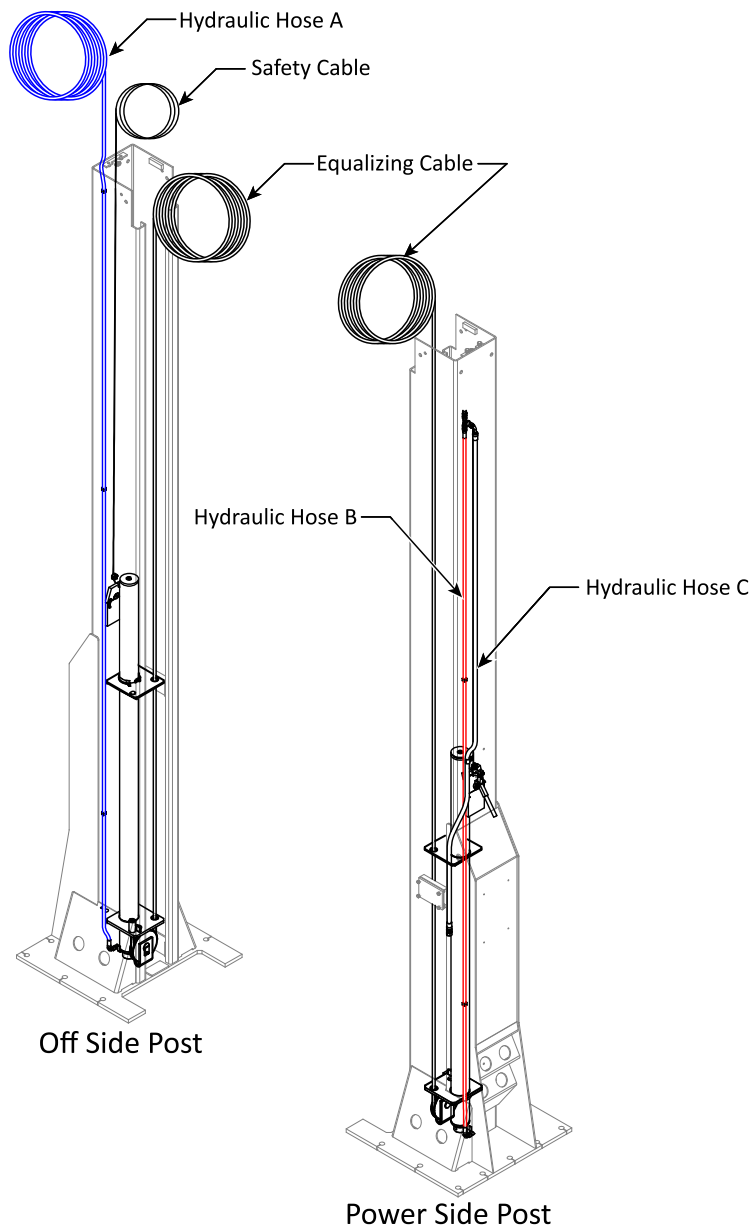

Create Chalk Line Guides

Based on the Specifications for the Lift, create Chalk Line Guides on the concrete floor for the two lift posts prior to moving them into position.

Use the **Overall Width** value in the **Specifications** for your Lift model to determine where to place the Chalk Line Guides. The Overall Width value is defined as the distance from the back of one base plate to the back of the other base plate. Refer to the figure below:

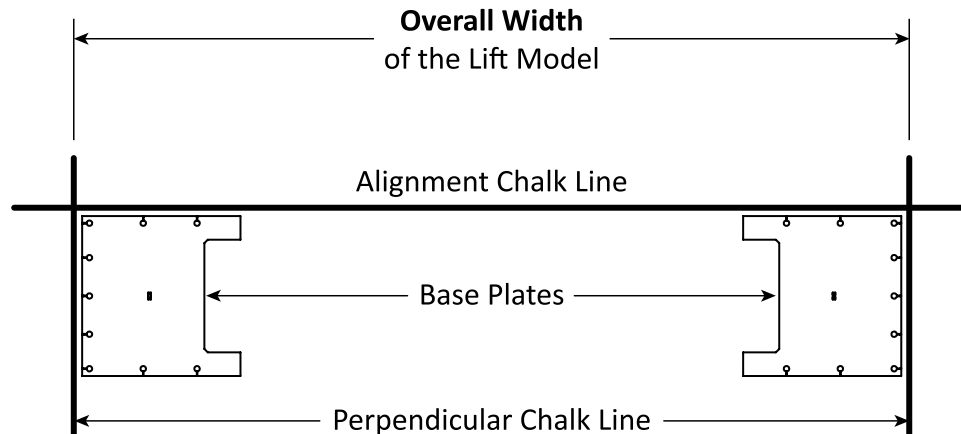

Top View of the Base Plates. Not all components are shown.

To create Chalk Line Guides:

1. Choose a location for the Lift.
2. Verify the clearances around and above the Lift area.
Create an Alignment Chalk Line at the Front of the Lift.
Make the Alignment Chalk Line longer than the **Overall Width** setting for your Lift model.
3. Create two Perpendicular Chalk Lines at a 90° angle to the Alignment Chalk Line and the distance between the lines is to be the **Overall Width** for the Lift model being installed.
4. When moving the lift posts in the next section, place the base plates into the corners created by the Chalk Line Guides as shown above.

Anchor the Posts

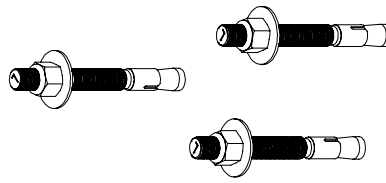

(18X) Anchor Bolts 3/4 in. x 7 in.
5530308

⚠ DANGER *Pay special attention when installing the Lift Posts. If done incorrectly, the Lift could fall over, potentially causing damage to the Vehicle, the Lift, and injuring bystanders. BendPak strongly recommends consulting a Concrete Specialist early in your planning process for Lift installations. A Concrete Specialist will make adjustments to account for national, state, and local building codes as well as local weather conditions, soil composition, base preparation, load bearing, seismic requirements and any other structural concerns that may arise.*

Concrete specifications are:

- **Depth:** 8 in. (203 mm) thick, minimum, steel reinforced.
- **Compressive Strength:** 3,000 psi min.
- **Cured:** 28 days, minimum

Anchor Bolt specifications are:

- **Length:** 7 in. (178 mm)
- **Diameter:** 0.75 in. (19 mm)
- **Anchor torque:** 85 – 95 ft. lb.
- **Effective embedment:** 3.25 inches (82.5 mm) or more

The concrete floor where the Lift will be installed must meet the following requirements:

- The concrete must be flat and level. **Do not install the Lift on a surface with more than three degrees of slope.**
- Do not install the Lift on cracked or defective concrete.
- Verify the concrete is **NOT** a post-tension slab. See [Selecting a Location](#).

⚠ WARNING Cutting through a post-tensioned cable can result in injury or death. Do not drill into a post-tension slab unless the building architect confirms you are **not** going to hit a tensioned cable, or you have located it using ground penetrating radar. If a colored sheath comes up during drilling, stop drilling immediately!

⚠ WARNING Your concrete **must** meet the minimum specifications listed above. Only install your Lift on a concrete surface. If you install a Lift on asphalt or any other surface, or your concrete does not meet these specifications, it could lead to product damage, vehicle damage, personal injury, or even loss of life.

BendPak Lifts are supplied with installation instructions and concrete fasteners meeting the criteria as prescribed by the latest version of the American National Standard “Automotive Lifts – Safety Requirements for Construction, Testing, and Validation.”

⚠ WARNING Use **only** the ALI-certified Anchor Bolts that are delivered with your Two-Post Lift. If components from a different source are utilized, this voids the warranty and compromises the safety of everyone who installs or uses the Lift.

Lift buyers are responsible for conforming to all regional, structural, and seismic anchoring requirements specified by any other agencies and/or codes, such as the Uniform Building Code and/or International Building Code.

NOTICE Consider **not** tightening the Anchor Bolts to a final torque value yet. Installing the overhead assembly and completing the final leveling is easier with some play in the posts.

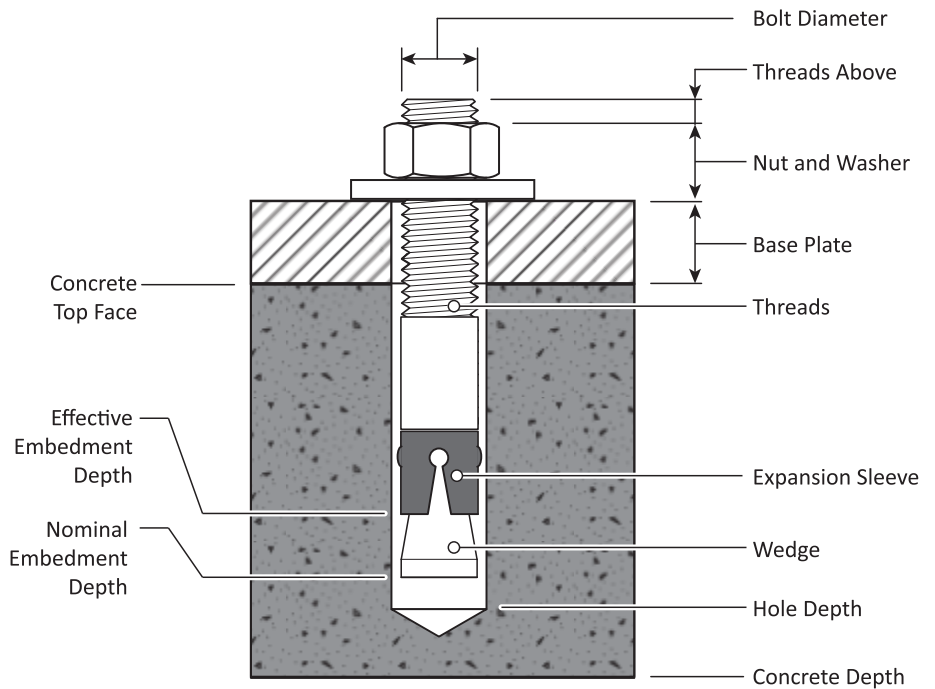

Effective Embedment is the location in the Hole where the Expansion Sleeve presses into the Concrete. This is where the Anchor Bolts get their holding strength, the further down into the hole, the greater the holding strength.

Nominal Embedment is how far down into the Hole the bottom of the Anchor Bolt is, which does not tell you anything about the holding strength.

WARNING Verify the Cylinder Clamp is in place above the lift head **prior** to raising the Lift Posts.

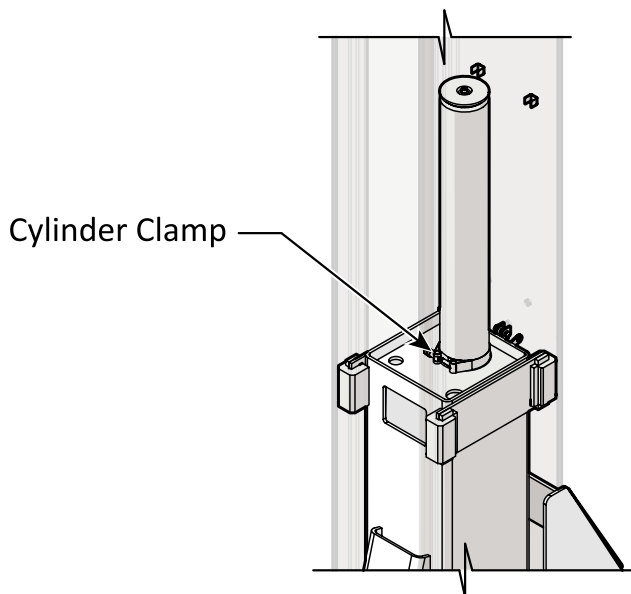

WARNING **Pinch and crush hazards! Keep hands and feet clear of the Lift Head and Lift Post as it is raised.** You **must** use the appropriate safety gear including safety glasses, dust masks, gloves, steel-toed work boots and heavy work clothes when anchoring the Posts.

To install the Posts:

1. Using a Forklift or Shop Crane, move the Posts to the Chalk Line Guides you created earlier. Carefully stand up each Post, *one at a time*, and move them to the appropriate location.
2. Double check your measurements against the **Specifications** for your Lift model.

3. Using the Base Plates as guides, drill each hole to a depth of **5 inches min.** using a masonry drill bit. Drill in straight; do not let the drill wobble.

The diameter of the drill bit must be the same as the diameter of the anchor bolt. Ensure the drill flutes are at least as long as the depth of the hole to effectively remove material as you drill.

Drill a pilot hole! Pilot holes allow straighter, cleaner drilling by removing the material directly from the center of the final drill. This reduces the amount of force required to keep the final drill straight and perpendicular to the floor.

If the drill hits rebar embedded in the concrete and the hole is not ruined, by making it too big or out of round, switch to a rebar cutting drill bit. Slow the drill speed to avoid overheating the drill bit. Continue drilling until you are past the rebar.

Do not rush. Pull the drill out of the hole frequently to remove debris and clear the opening.

Do not drill all the way through the Concrete; if you punch completely through the slab, you could compromise the holding strength of the Anchor Bolts.

4. Vacuum each hole clean.

BendPak recommends using a vacuum to get the hole very clean.

A wire brush, hand pump, or compressed air may also be used. **Make sure to thoroughly clean each hole.**

Do **not** ream the hole. Do **not** make the hole any wider than the drill bit made it.

⚠ WARNING You **must** use the appropriate safety gear including safety glasses, dust masks, gloves, steel-toed work boots and heavy work clothes when anchoring the Posts.

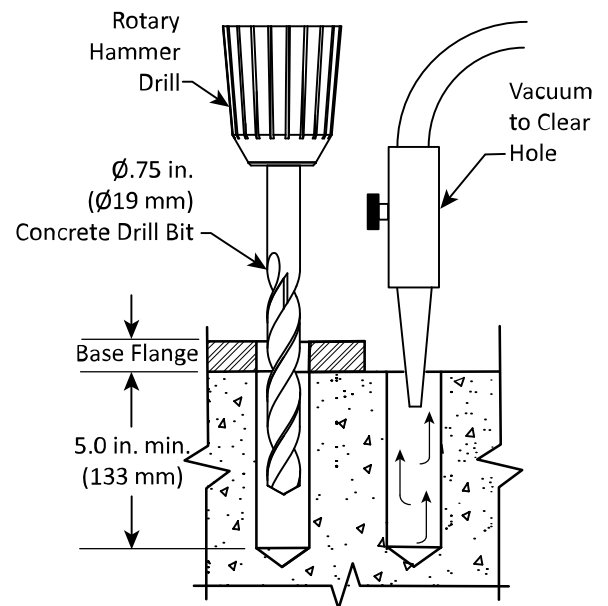
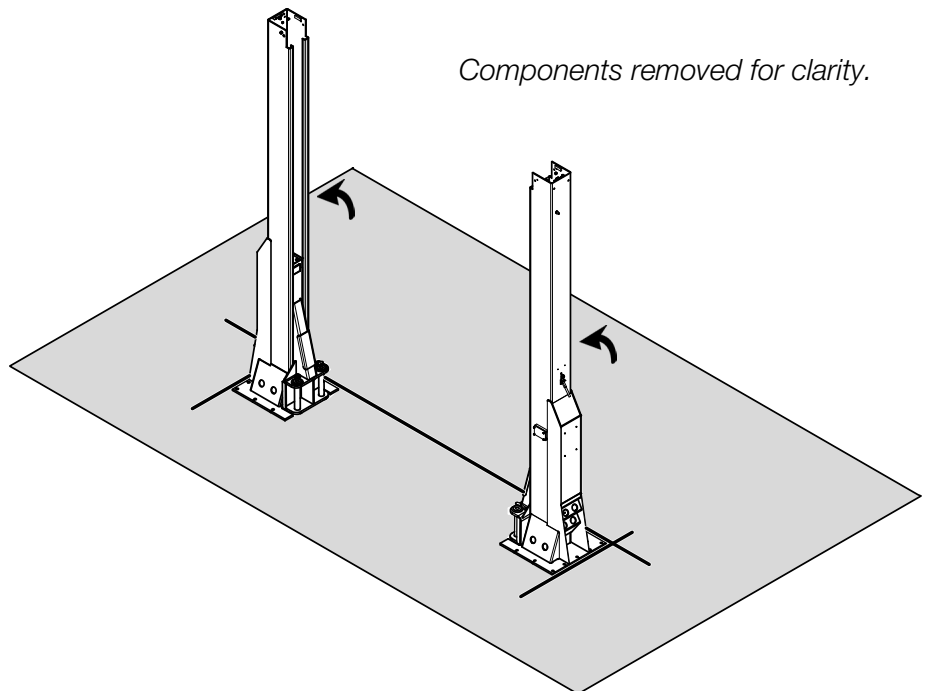

NOTICE

The holding strength of an anchor bolt is partially based on the how cleanly the expansion sleeve presses against the concrete. If the hole is dirty or too wide, holding strength is reduced.

5. Make sure the Washer and Nut are in place, then insert the anchor bolt into the hole.

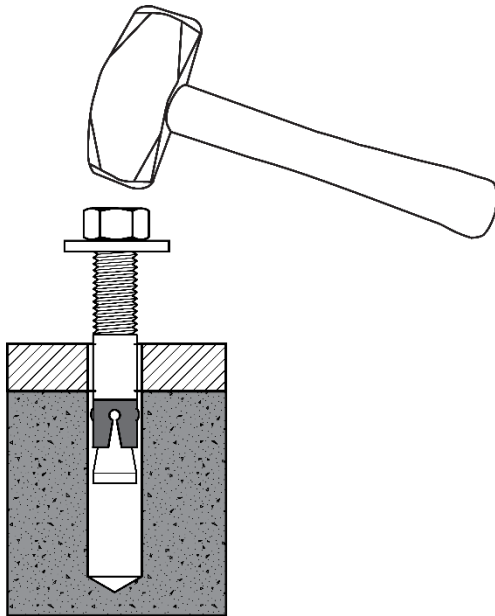

The expansion sleeve of the anchor bolt may prevent the anchor bolt from passing through the hole in the base plate; this is normal. Use a hammer or mallet to tap the expansion sleeve through the base plate and into the hole.

Even using a hammer or mallet, the anchor bolt should only go into the hole part of the way; this is normal. If the Anchor Bolt goes all the in with little or no resistance, the hole is too wide.

Once past the hole in the base plate, the anchor bolt eventually stops moving down into the hole as the expansion sleeve contacts the sides of the hole; this is normal.

6. Hammer or mallet the anchor bolt the rest of the way down into the hole, and then stop when the washer is snug against the base plate.
7. Plumb each Post; install Shims as required. See **Troubleshooting Lift Arm Lock Disengagement** if you are required to shim $\geq .5$ in (13 mm).

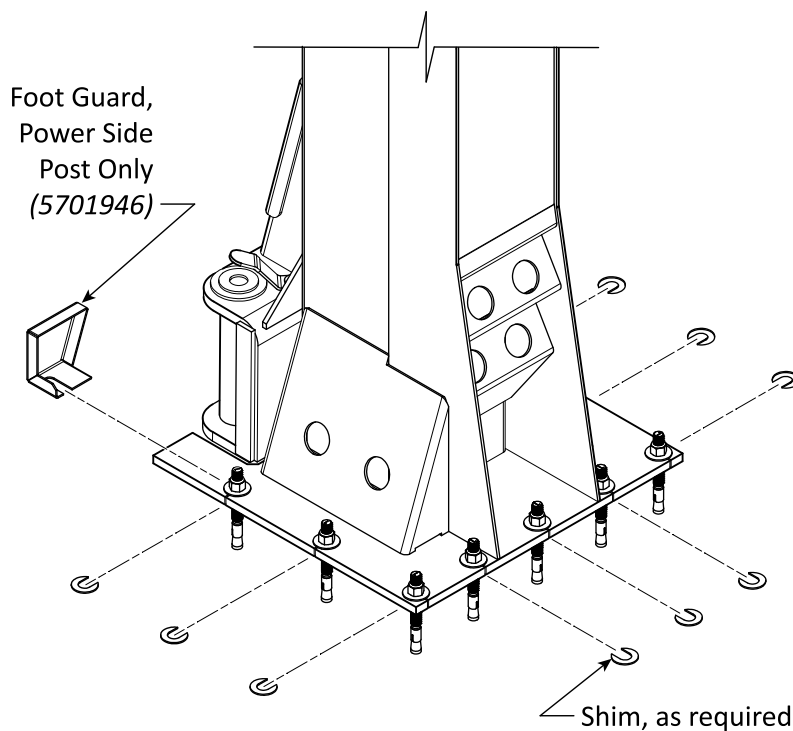

**Tip**

If planning to torque the Anchor Bolts later, so that installing the Overhead Assembly and final leveling is a little easier, skip the next step. Make sure the Anchor Bolts are securely in position; This will ensure that the Posts will not move too much during the rest of the installation.

8. Tighten each nut **clockwise** to the recommended installation torque, 85 – 95 pound feet, using a Torque Wrench.

**CAUTION**

Do **not** use an impact wrench to torque the Anchor Bolts.

9. Install the **Foot Guard** on the power side post as shown in the figure above and below.

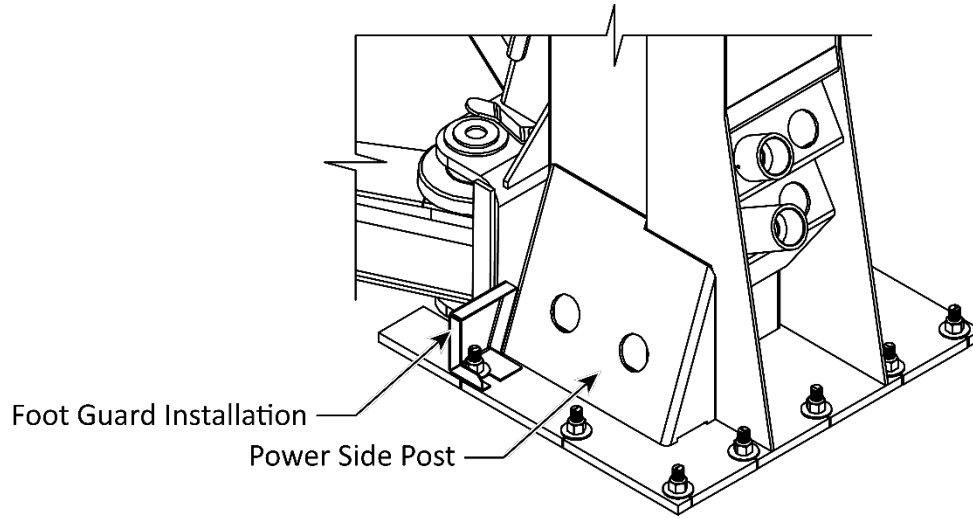

Install the Overhead Assembly and Safety Shutoff Bar

The Overhead Assembly is installed above and between the power side and off side posts. It routes and protects the equalizing cables, the hydraulic hoses, the overhead limit switch wiring and mechanism, and the Safety Lock Cable.

IMPORTANT! Orient the Overhead Assembly so that the Limit Switch is closer to the Power Side Post! Refer to the figure below.

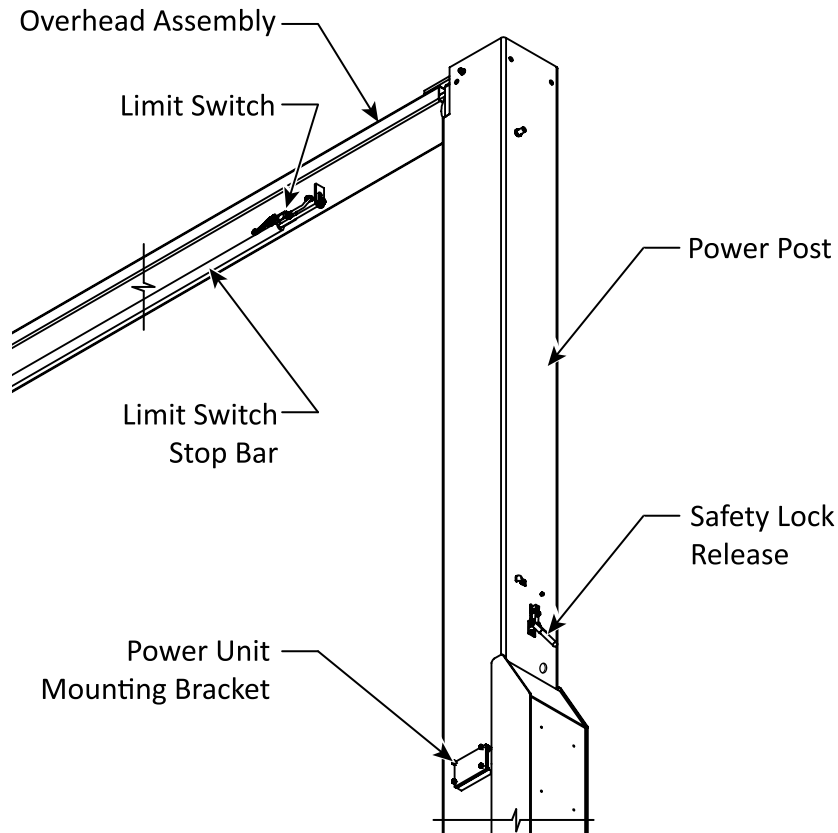

To prepare and install the Overhead Assembly:

1. Remove all four overhead sheaves, their pins, and fasteners from the ends of the overhead assembly. Keep the sheaves and components nearby.
2. Retrieve the Limit Switch and fasteners from the Parts Box.

Use the supplied hardware to secure the overhead limit

switch in place. If **two** overhead limit switches are included with the Lift, a three-phase Power Unit is to be installed, install the two switches next to each other on the Limit Switch Bracket.

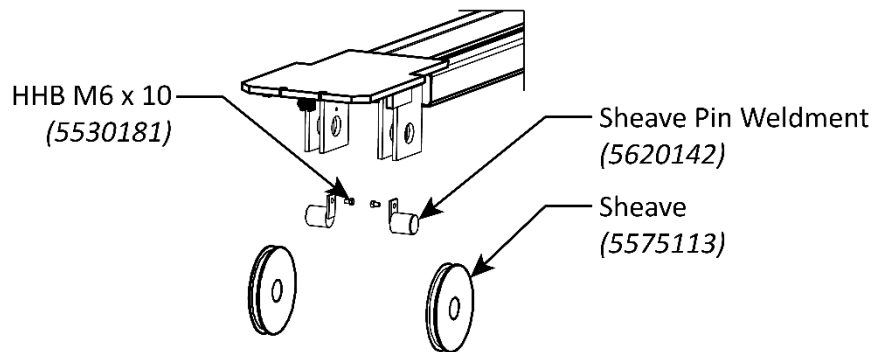

For Three-Phase Installations see [Three-Phase Limit Switches Installation](#).

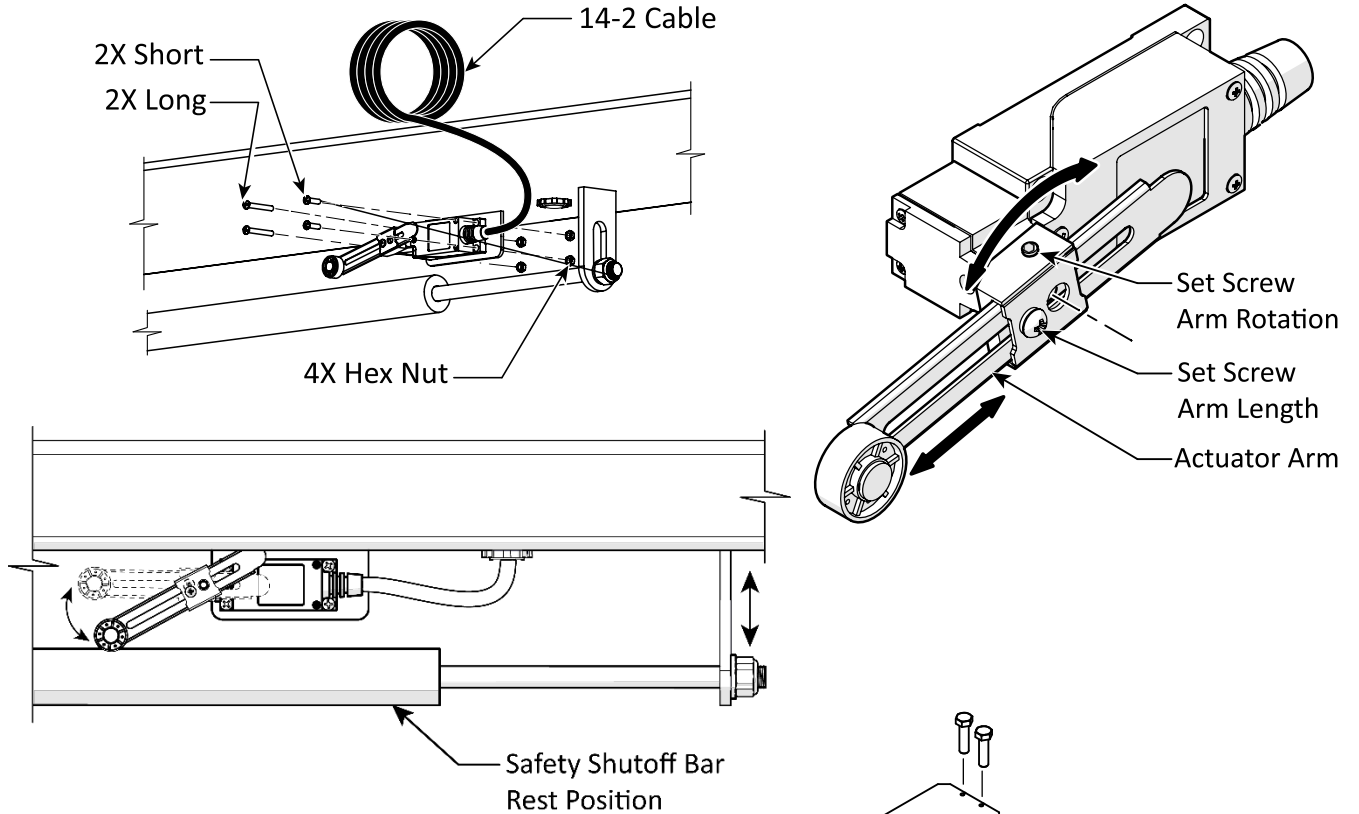

3. Adjust the overhead limit switch actuator arm such that the Safety Shutoff Bar, when moved upwards, will push the actuator upwards.
4. Use an appropriate lifting device to move the Overhead Assembly into position, **making sure to position the overhead limit switch bracket on the same side as the power side post.**
5. Bolt the overhead assembly to the top of the posts using two bolts, lock washers and hex nuts on each end of the overhead.
6. Install the Romex Connector in the overhead assembly.

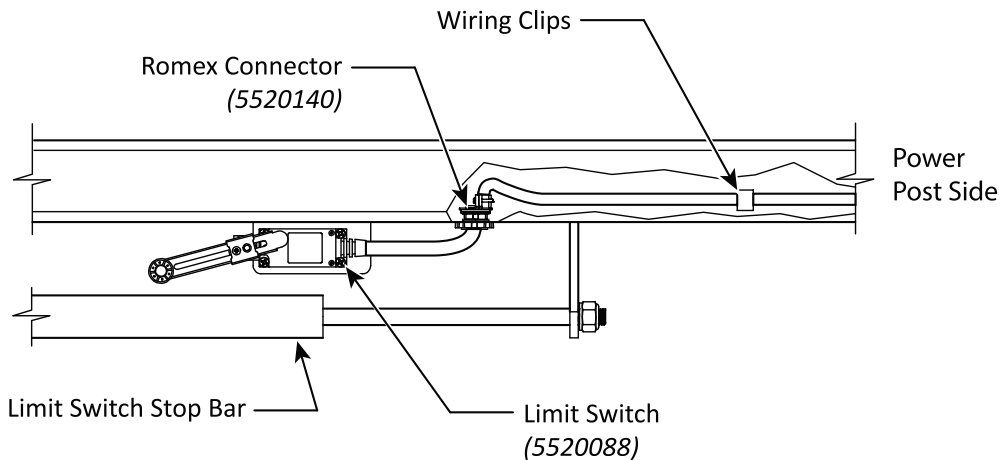
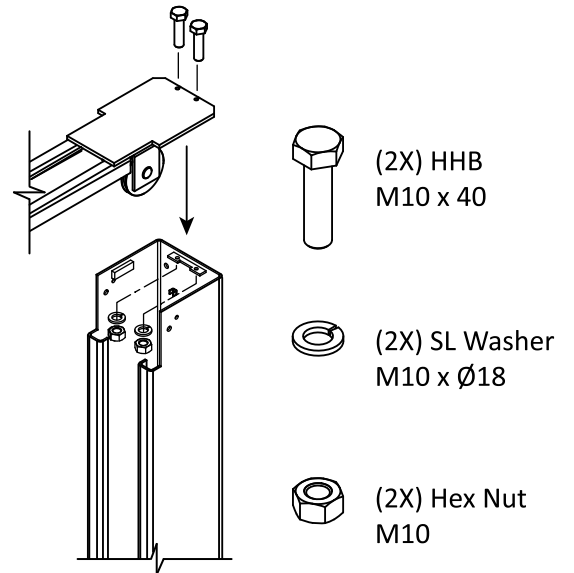

7. Route the 14/2 Cable from the overhead Limit Switch through the Romex Connector and along the overhead. Place the cable into the wiring clips and lightly close or crimp the clips. Do not cut or damage the cable insulation with tools or the clips.
8. Tighten the Romex connector. Take care not to damage the cable by over tightening the Romex connector.
9. Route the cable through the overhead and down the power side post through the wiring clips down toward the safety lock and the top of the lift head.
10. Lightly crimp the wiring clips inside the Lift Post to hold the cable in place.
11. Retrieve the grommet (5520001) from the parts box and install it in the power side post below the safety lock. Refer to the figure below.
12. Route the cable through the grommet and allow it to hang outside the post. The Electrician will make the final wiring connections.

IMPORTANT! Verify all electrical cables and hoses are secured in their clips inside both Lift Posts and routed to avoid moving components and pinch points.

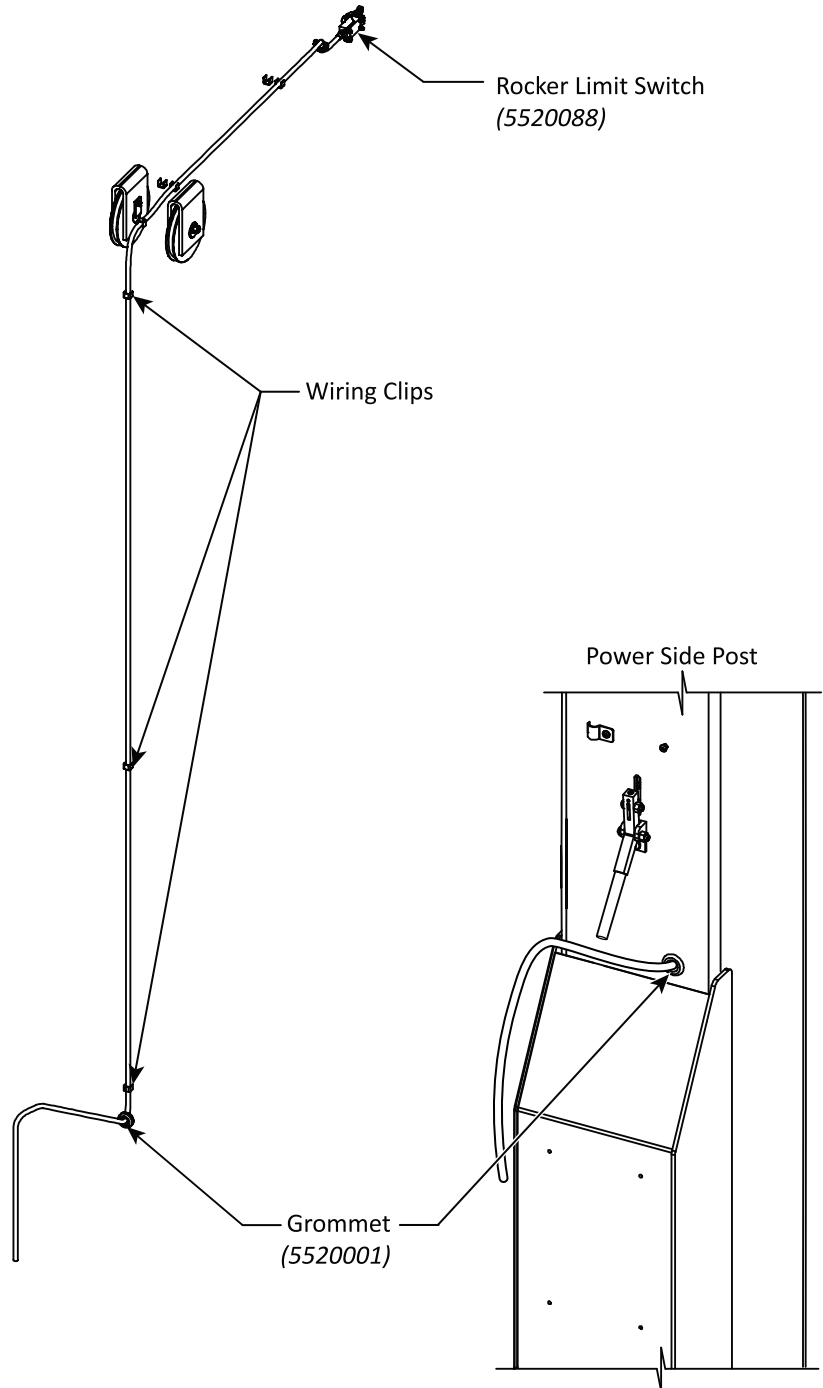

Complete the Equalizing Cables Installation

Both Equalizing Cables should have been moved into position and coiled at the top of the lift posts before the posts were raised, which was covered in [Putting the Equalizing Cables into Position](#).

The button ends of the equalizing cables (on both posts) have been installed, routed around the post sheaves, and then pushed up above the lift head. These cables will now be routed over the overhead assembly and down to the top of each lift head.

NOTICE If your equalizing cables are not yet in position, go back to that section and put them into position before continuing with this procedure.

When the equalizing cables are correctly routed, they are mirror images of each other. Refer to the figure below.

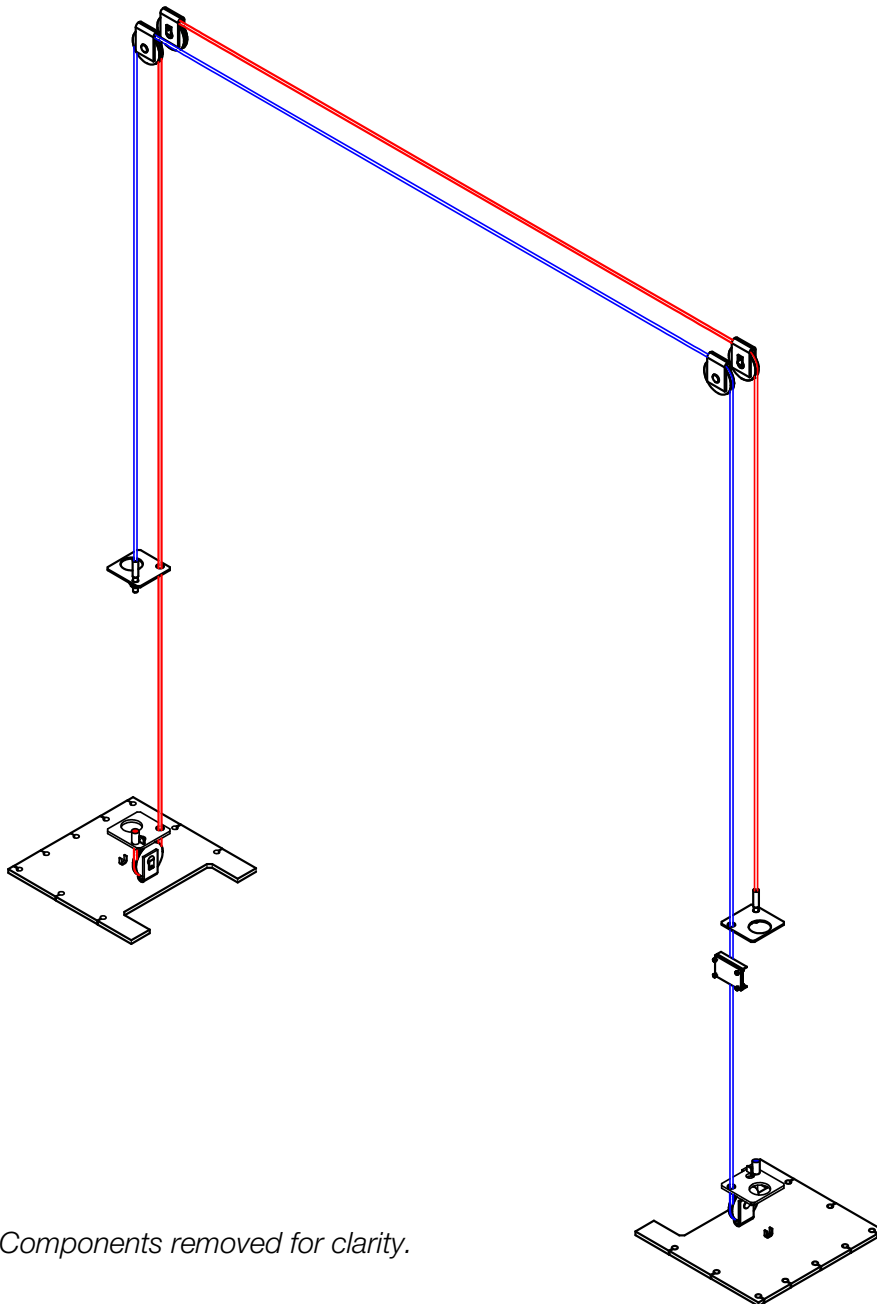

Not to scale. Components removed for clarity.

To route the Equalizing Cables:

1. Using a Forklift or Shop Crane, raise both lift heads to about 28 inches (711 mm) off the ground and engage them on the closest safety lock.

Measure to verify both Lift Heads are the same distance off the ground.

⚠ WARNING The Lift Heads are heavy! Installation should be accomplished by competent personnel ensuring all heavy components are properly rigged and balanced for lifting. Installation personnel should have knowledge, training, and experience in lifting, rigging, and securing heavy objects.

Use proper lifting devices such as a Forklift or Shop Crane to raise and position the Lift Heads.

2. Verify the button ends of both equalizing cables are still in the slots in their cable button stops, that both equalizing cables are routed under the post sheave, and that the threaded cable end is routed through the hole at the top of the lift head.

Do not proceed until the equalizing cables are in their correct starting positions.

3. Choose one of the two equalizing cables to put into position, then remove the nut from the threaded end of that cable.
4. Route the Threaded End of the Equalizing Cable up the inside of the Post, to the Overhead Assembly, and then out over the top of the Overhead Assembly.

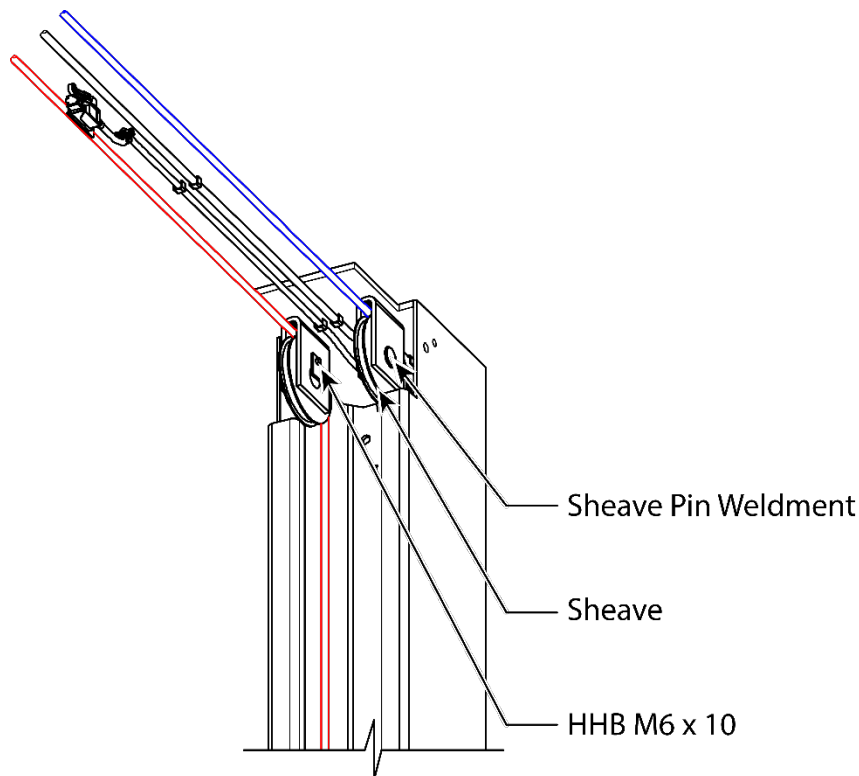

Components removed for clarity.

5. Route the Equalizing Cable down to the opposite Lift Head.
6. Lubricate the both Sheave Pins and Bearings with red lithium grease, then re-install the Sheaves, Sheave Pins, and secure with the M6 x 10 hex head bolts.
7. At the other Post, repeat the procedure with the other Equalizing Cable.

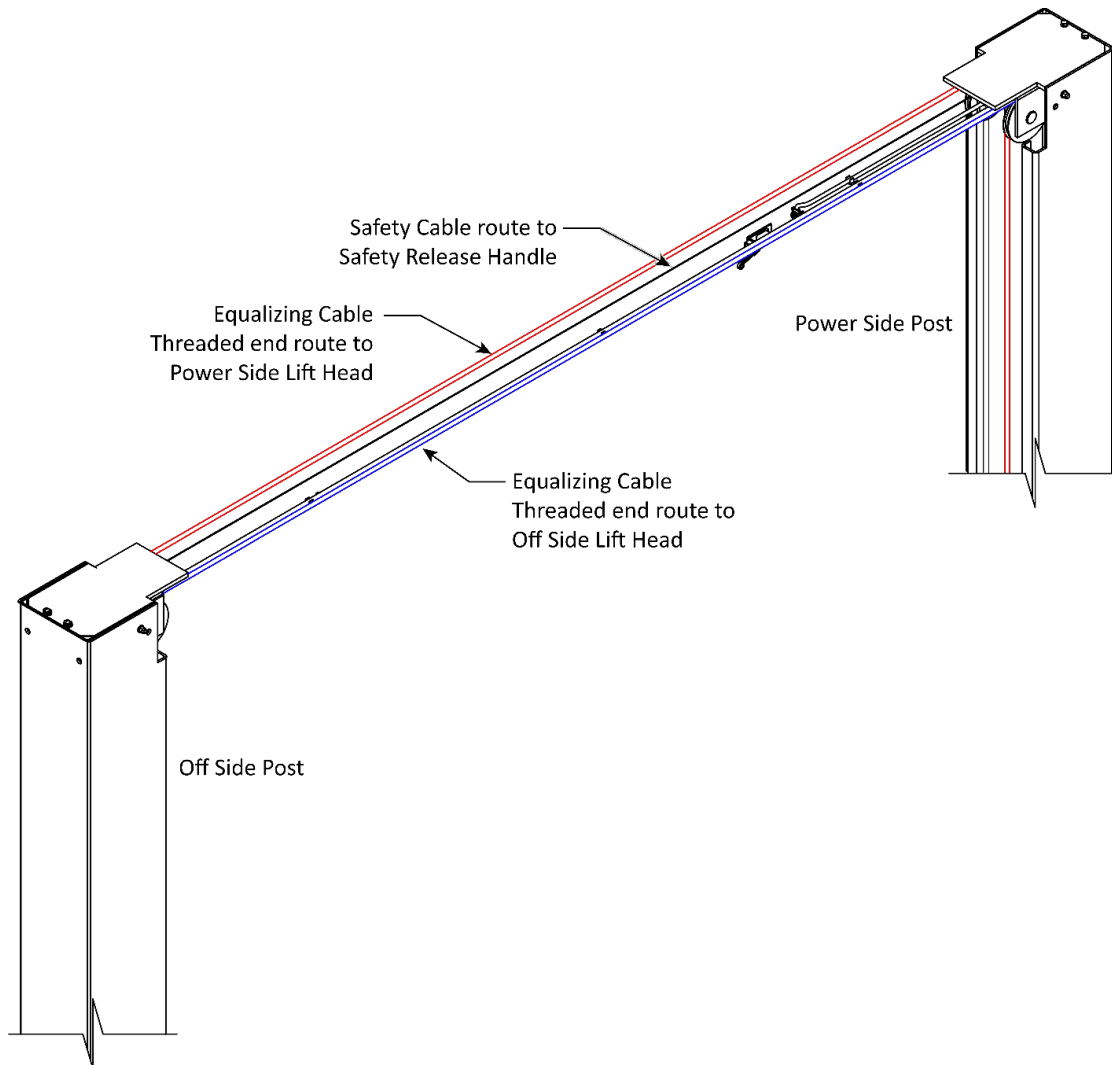

Components removed for clarity.

8. Install the threaded end of the Equalizing Cable through the hole at the top of the Lift Head, then install the flat washer, hex nut, and tighten.

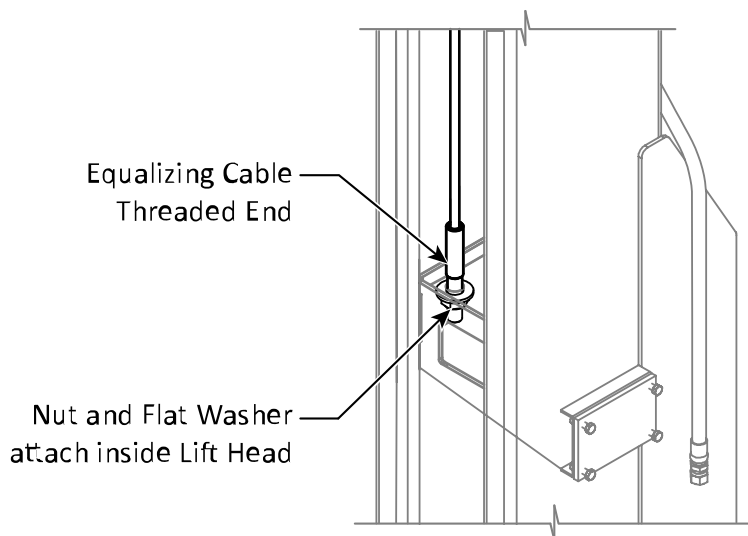

9. Perform Steps 3 through 9 for the remaining Equalizing Cable.

Mount the Power Unit

This section describes mounting the Power Unit to the power side post. You do **not** need an Electrician to **mount** the Power Unit, but you do need an Electrician to **connect** the Power Unit to the facilities electrical system. Refer to **Connecting the Power Unit** for installation information for your Electrician and specific information about the Power Unit that came with your Lift.

NOTICE Do not connect the Power Unit to the Hydraulic System or to the power source at this point in the installation; those connections will be made later.

CAUTION The Power Unit is heavy. BendPak recommends having one person hold the Power Unit while a second person bolts it into place.

To mount the Power Unit:

1. Retrieve the supplied four M8 Hex Head Bolts, M8 Lock Washers, and one Vibration Dampener.
2. Remove the Power Unit from the packaging material.

Important The Power Unit is heavy. BendPak recommends having one person hold the Power Unit while a second person bolts it into place.

3. Put the Vibration Dampener into place next to the Mounting Bracket on the power side Post.
4. Move the Power Unit Mount Plate next to the Vibration Dampener.
5. Secure the Power Unit and Vibration Dampener using the fasteners listed in step 1, using all four holes to secure the Power Unit. Refer to the figure below.

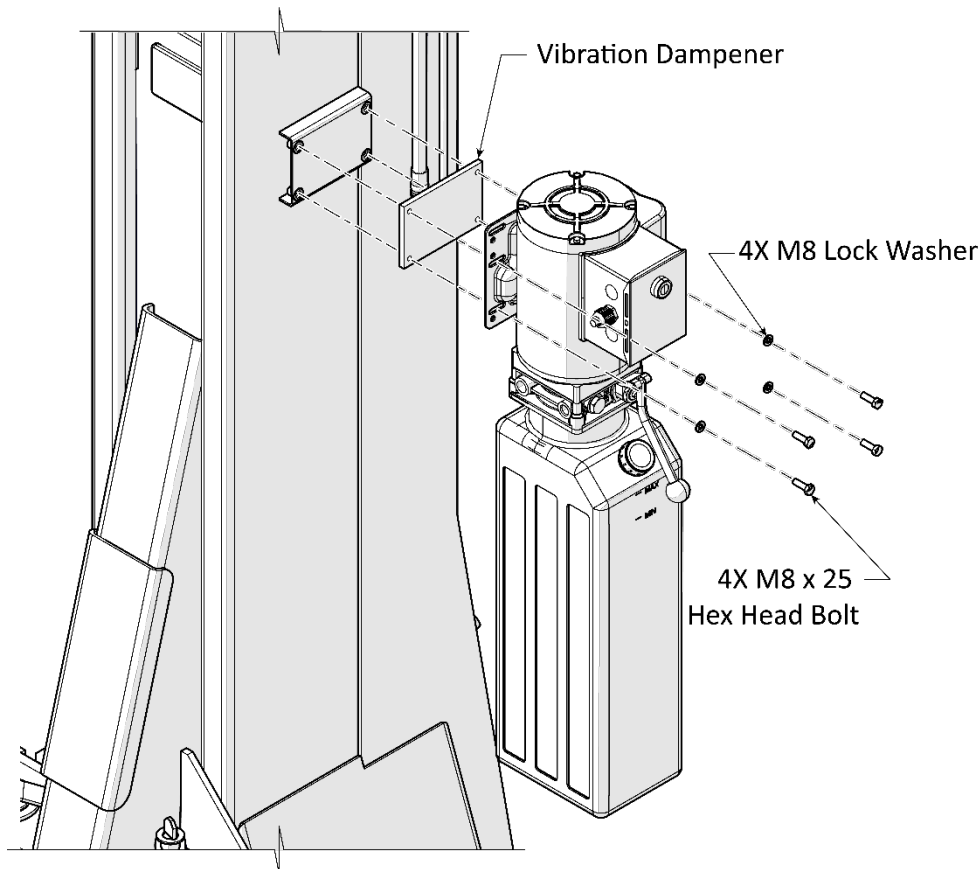

Route and Install the Safety Lock Cable

The Safety Lock Cable and the Safety Lock Release Handle are used to release the Safety Locks, allowing the Lift to be lowered. The Safety Lock Cable should have been installed and left in place in the **Installing the Safety Assemblies** section. The following drawing shows the path the Safety Lock Cable travels from Safety Assembly on the off side post to the Safety Assembly on the power side Post.

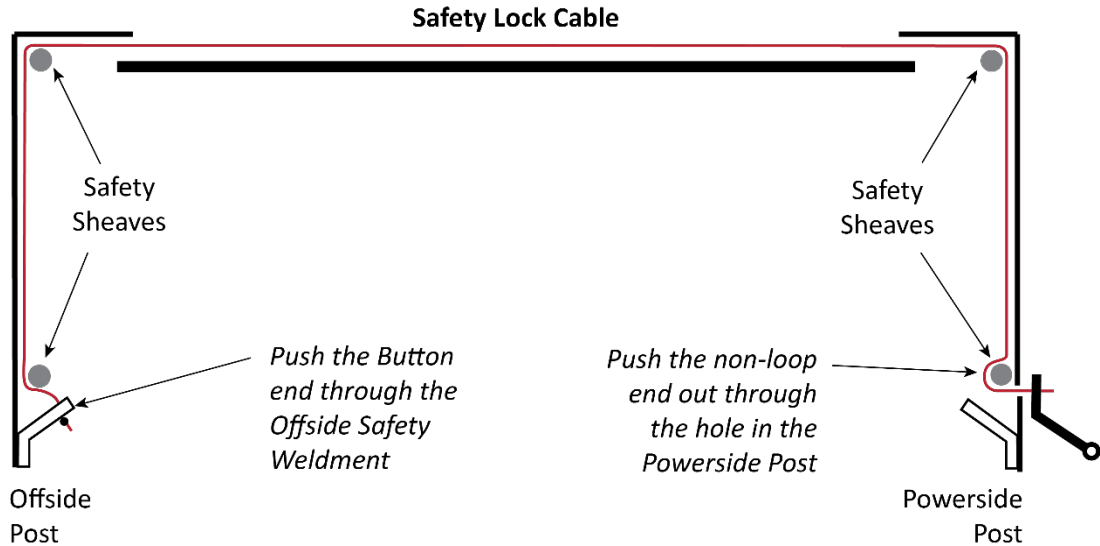

Not drawn to scale. Some components exaggerated or not shown for clarity.

The figure below details the Safety Lock Cable connections to both Safety Assemblies.

Offside Safety:

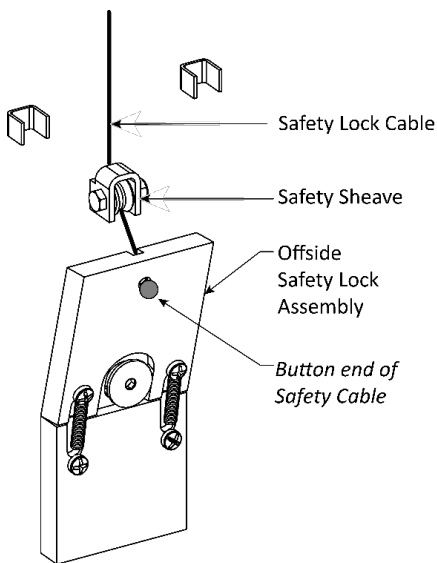

Power Side Safety:

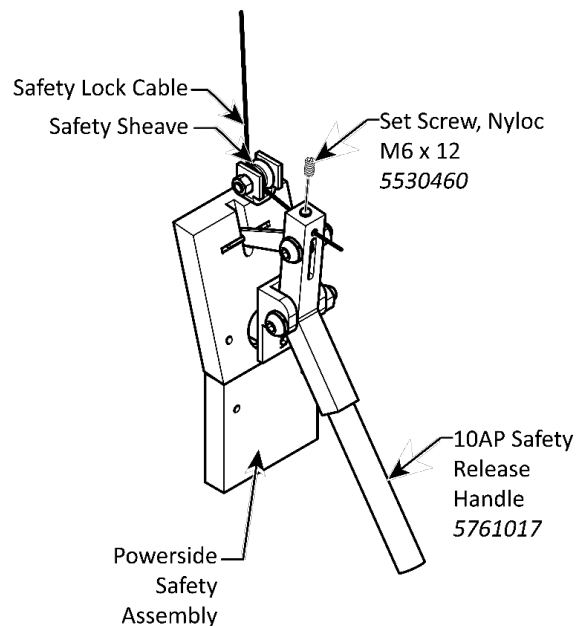

⚠ WARNING

You will need to access the Overhead Assembly to route the Safety Lock Cable. Use care to avoid falling when working on a ladder or other lifting device.

To route and connect the Safety Lock Cable:

1. Locate the Safety Lock Cable. This should be coiled at the top of the off side post.
2. Route the non-button end under the Safety Sheave, upwards on the inside of the off side post, up and over the Safety Sheave at the top of the off side post, across the Overhead Assembly, over the Safety Sheave at the top of the power side Post, and then downwards, on the inside of the power side Post, towards the power side Safety Assembly.
3. **Switching to the power side Post**, route the non-button end of the Safety Lock Cable through the Safety Sheave.
4. Retrieve the M6 x 12 Set Screw (5530460) from the Parts Bag.
5. Route the Safety Lock Cable through the hole in the Safety Release Handle, then thread and tighten the set screw through the top of the handle to secure the safety cable. Refer to the figure below.

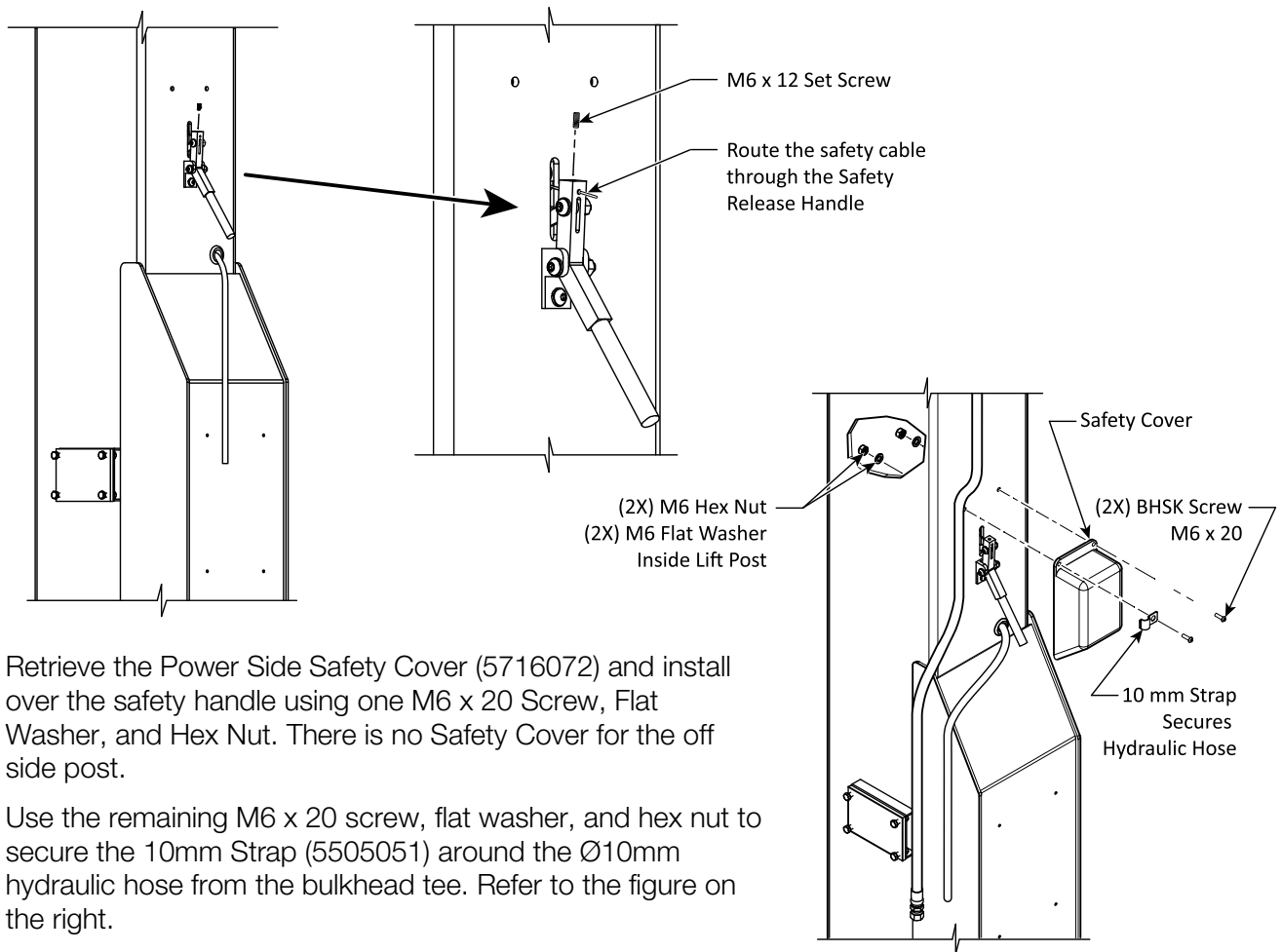

6. Retrieve the Power Side Safety Cover (5716072) and install over the safety handle using one M6 x 20 Screw, Flat Washer, and Hex Nut. There is no Safety Cover for the off side post.
7. Use the remaining M6 x 20 screw, flat washer, and hex nut to secure the 10mm Strap (5505051) around the $\varnothing 10\text{mm}$ hydraulic hose from the bulkhead tee. Refer to the figure on the right.

⚠ CAUTION Verify the Safety Lock Cable remains in its Safety Sheaves; this keeps it out of the way of the Equalizing Cables and the Hydraulic Hoses.

⚠ DANGER Verify both the power side and the Offside Safety Assemblies engage/disengage properly **before** operating the Lift.

Connect the Hydraulic Hoses

The Hydraulic Hoses were put into place much earlier in the installation. If they were **not** put into position earlier, you must do so now, **before** proceeding. Refer to [Routing the Hydraulic Hoses](#) for full instructions.

To complete the Hydraulic Hose connections:

1. Route, then connect the straight end of Hose A to the Tee Fitting. Make finger tight.

This connection is made on the inside of the power side post. If the 06 JIC connector of the Tee Fitting is **not** on the outside of the power side Post, this means the Tee Fitting was not installed correctly. Return to [Routing the Hydraulic Hoses](#) for more information.
2. Verify all hydraulic hoses are secured in their clips in both lift posts and the overhead assembly. Hydraulic hoses are to be routed over the double threaded rod not under.
3. Retrieve the Elbow ORB fitting (5550183) from the Parts Bag.
4. Locate a pressure port on the Power Unit (labelled P, P1 or P2). Remove the shipping plug. *Apply a few drops of hydraulic fluid to the O-Ring. This will prevent damage to the O-Ring and ensure a good seal. Install the O-ring side of the fitting into the Power Unit's pressure port.*
5. Tighten the Elbow Fitting appropriately; make sure to leave the 06 JIC connector side facing up, towards the Tee Fitting.
6. **Important:** Overtightening will damage the O-ring and under tightening will result in leaks.
7. Connect the Straight End of the Hydraulic Hose C (Ø10 x 2,790 mm) to the JIC side of the ORB Elbow Fitting. Make this connection finger tight.
8. Using appropriate tools, securely tighten all hydraulic hose connections.

IMPORTANT!
Verify all hydraulic hoses and electrical wiring is secured by clips inside the Lift Posts. All cables and hoses must be tight and flat inside the Posts and routed to avoid moving components and pinch points.

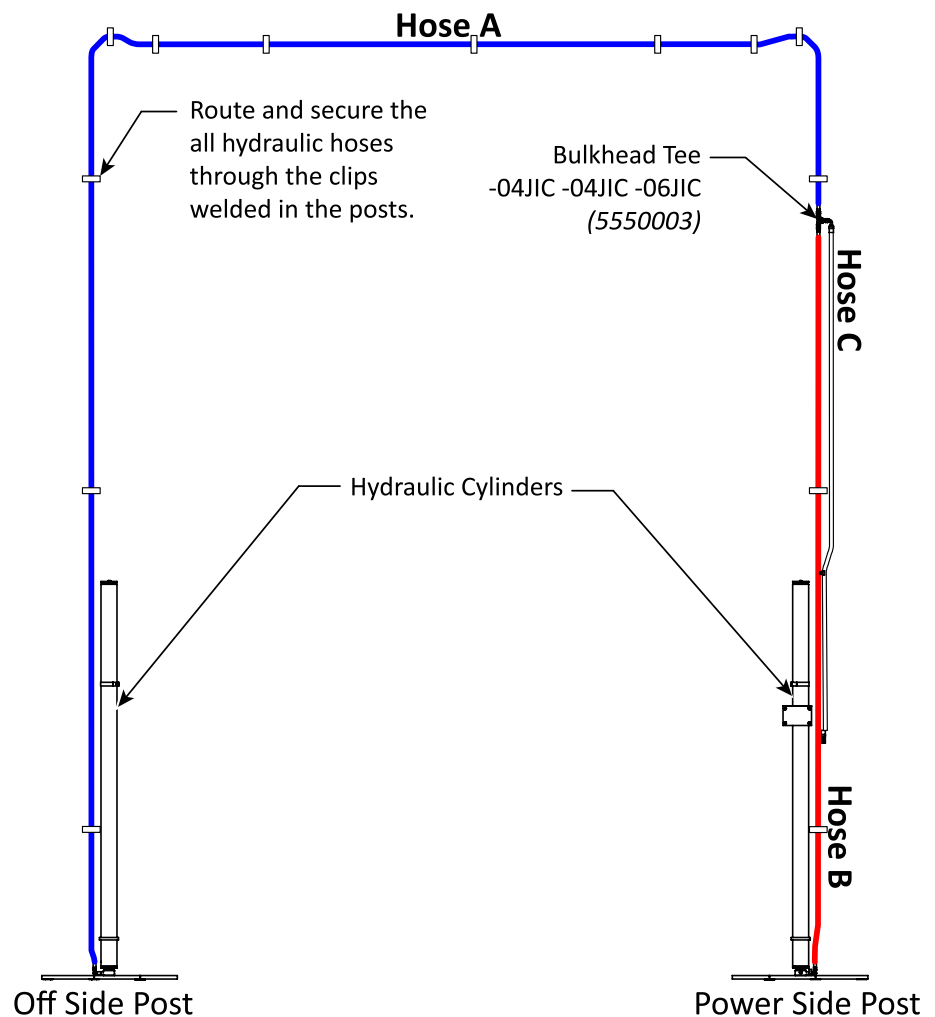

Important:

There are multiple ports on Power Units used with AP Series Lifts. The Lift uses only one Hydraulic Pressure Port. Do **not** connect to any of the other Ports and do **not** connect to more than one Hydraulic Pressure Port. Refer to the figure below.

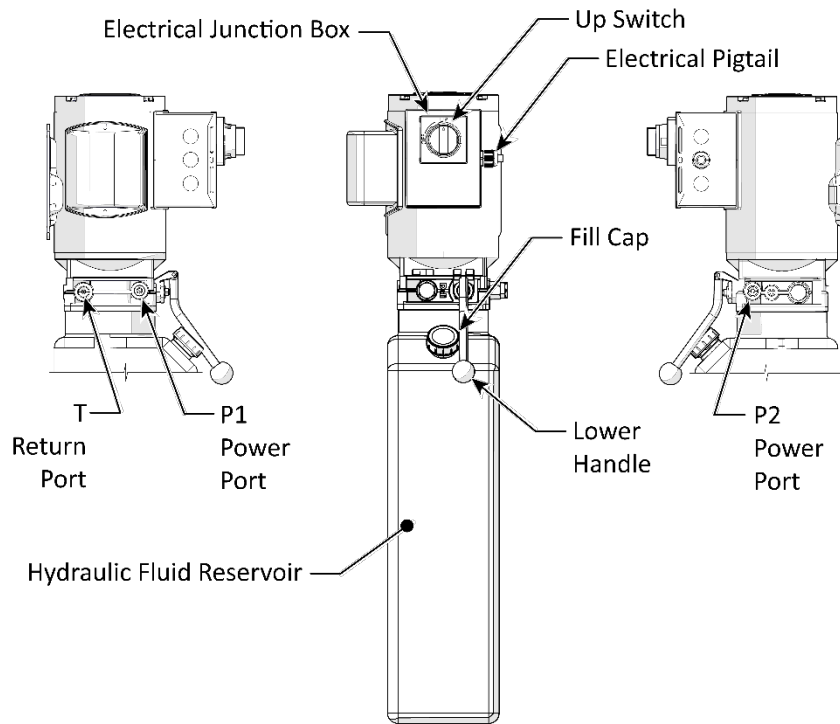
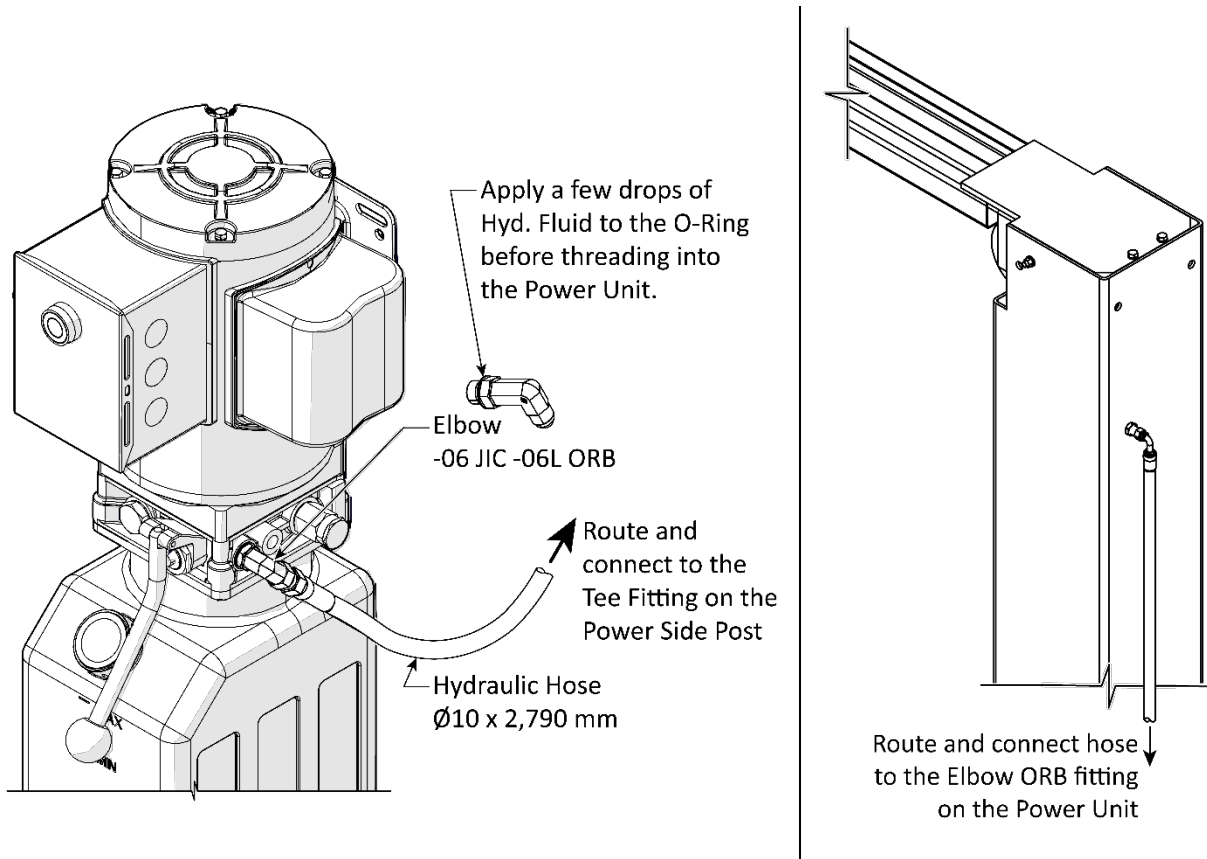

Install the Lift Arms

Install the Lift Arms as detailed in the procedure below.

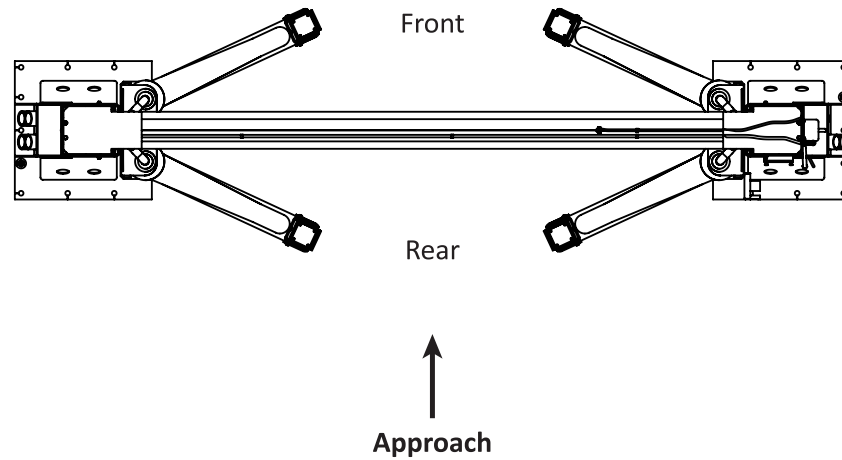

To install the Lift Arms in the Lift Head:

1. Using a Forklift or Shop Crane, raise the Lift Heads to the first locking position.

⚠ WARNING The Lift Head and Lift Arms are heavy. Exercise caution when raising the Lift Head to the first locking position using a Forklift or Shop Crane. Wear personal protective equipment. Beware of pinch points and crush injuries.

2. Retrieve the M6 Set Screws from the Parts Bag.
3. Remove and retain the Compression Spring and the Arm Internal Gear Stop from the Lift Head. Refer to the figures below.

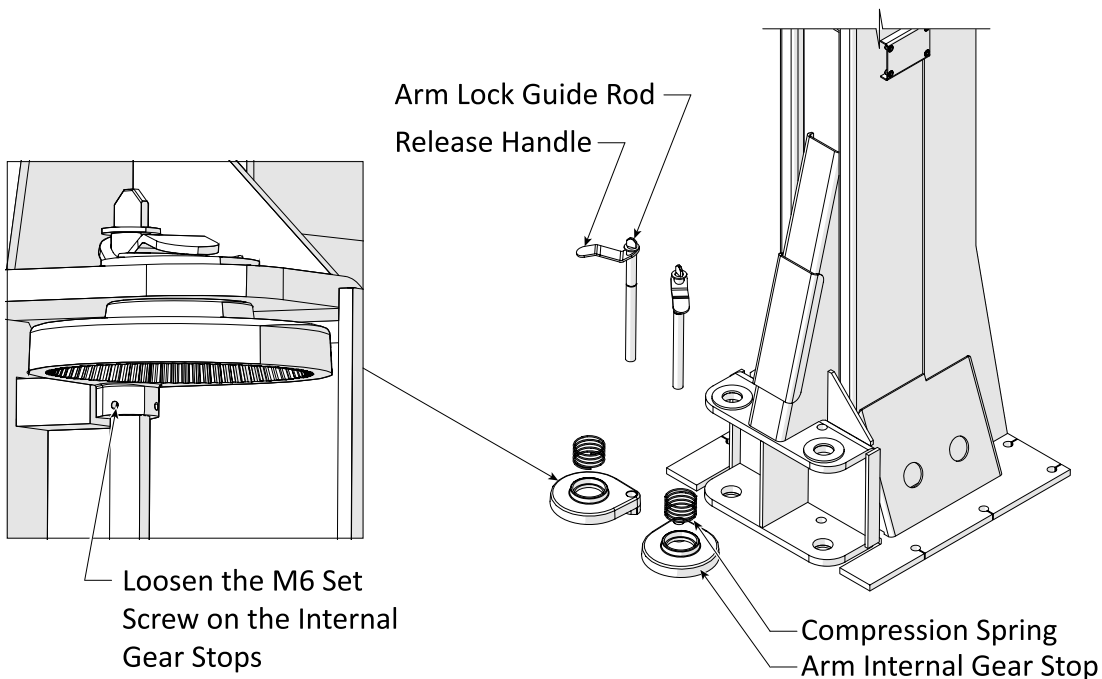

-
4. Place the Arm Internal Gear Stop and Compression Spring on the Lift Arm.

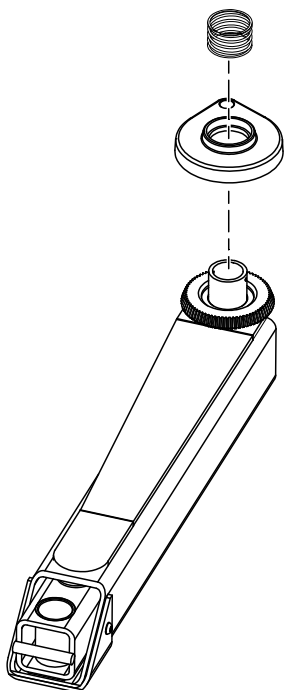

5. Insert the Lift Arm into the Lift Head, then slide the Arm Lock Guide Rod through the openings in the Lift Head and Lift Arm Assembly (refer to the figure below).

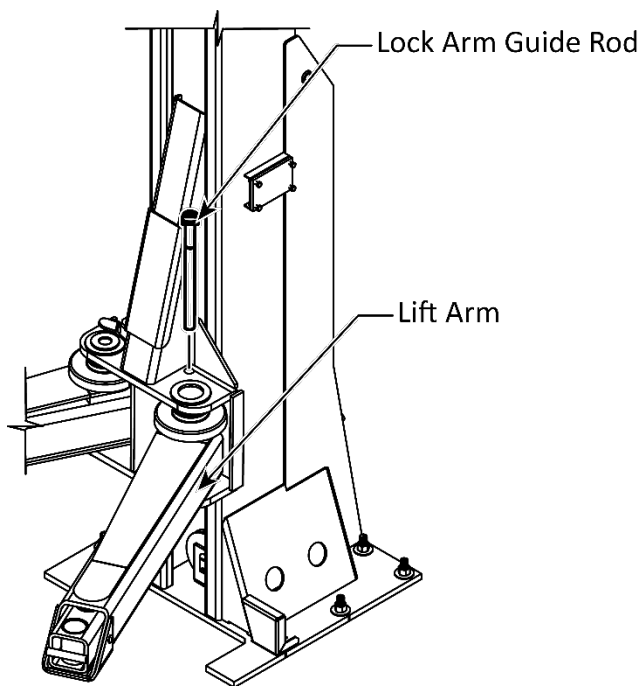

6. Tighten one M6 set screw through the Arm Internal Gear Stop into the groove machined into the Lock Arm Guide.

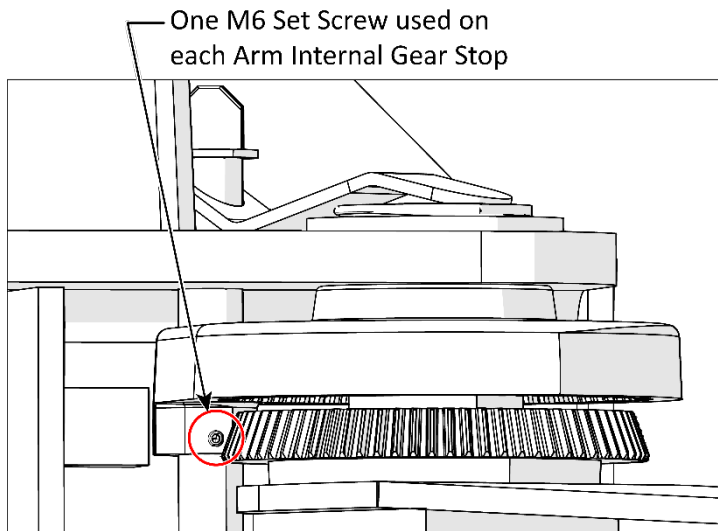

7. Insert the Arm Lock Pin through the holes in the Lift Head and into the Lift Arm Assembly.

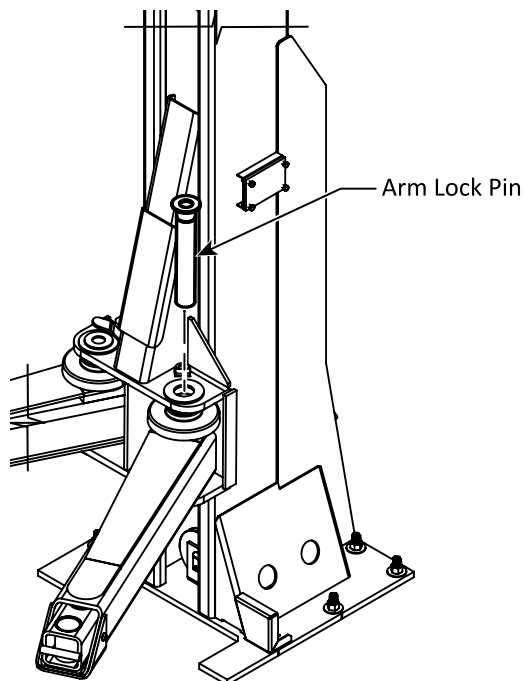

8. Retrieve an M6 x 12 Cone Point Set Screw and thread one set screw into the Arm Weldment Mount Tube securing the Arm Lock Pin.

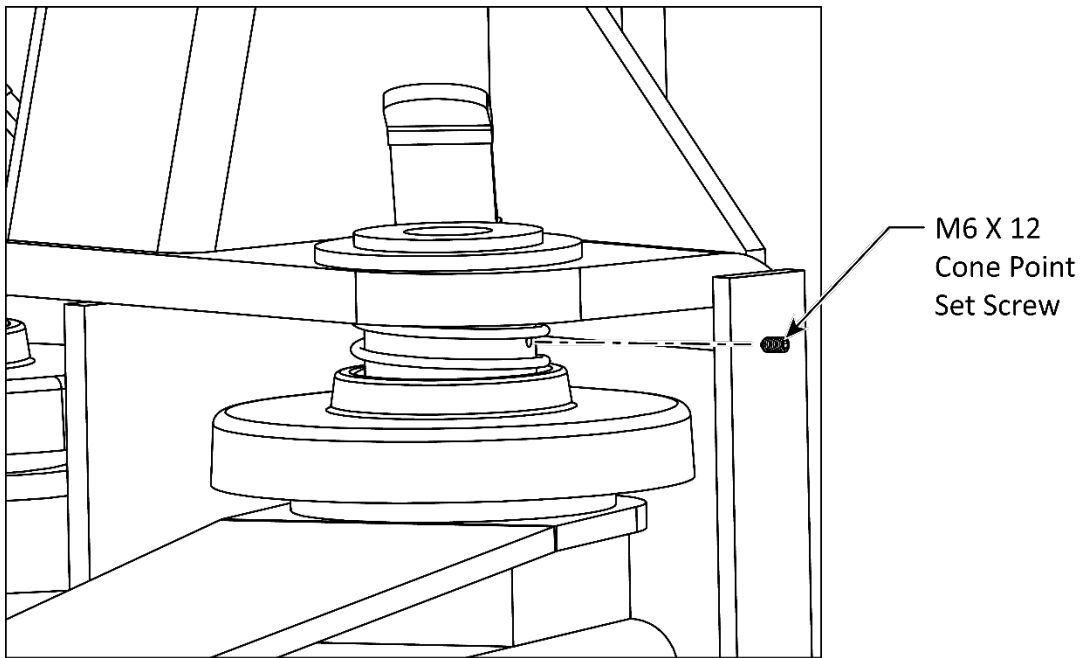

Reference only – do not scale.

- Repeat Steps 1 through 8 for the remaining three Lift Arm Assemblies.

⚠ WARNING Verify the Arm Restraint Gears and the Internal Gear Stops are meshing and remain in place when up to 150 pounds of lateral force is applied before putting the Lift into normal operation.

⚠ DANGER Each Lift Arm Assembly **must** be inspected and adjusted as required before each use. Do not operate the Lift if any of the four Lift Arm restraint systems are not functioning correctly. Replace any damaged components with approved replacement parts.

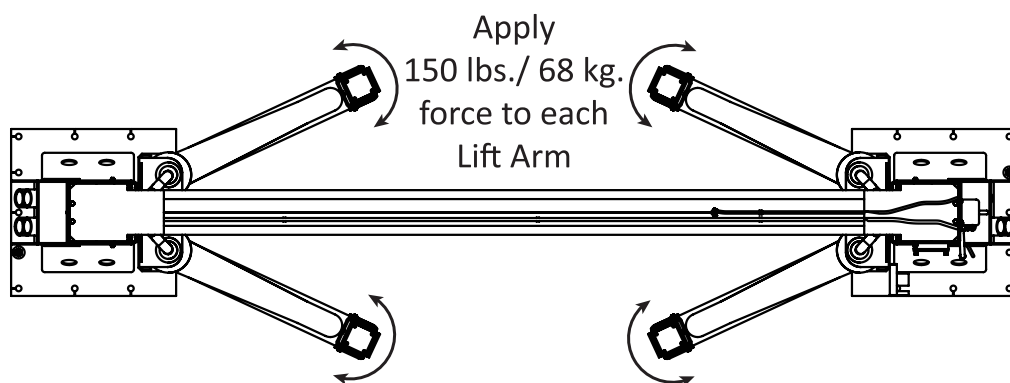

Install the Double Threaded Rod

The Double Threaded Rods, as shown below, **must** be installed with M10 flat washers (5545341) and M10 Hex Nuts (5535013) on each Lift Post. Torque the Hex Nuts to 2-3 ft. lb. *Hydraulic Hoses are to be routed over the Double Threaded Rods.*

⚠ WARNING The Double Threaded Rods must be installed to ensure proper operation of the Lift.

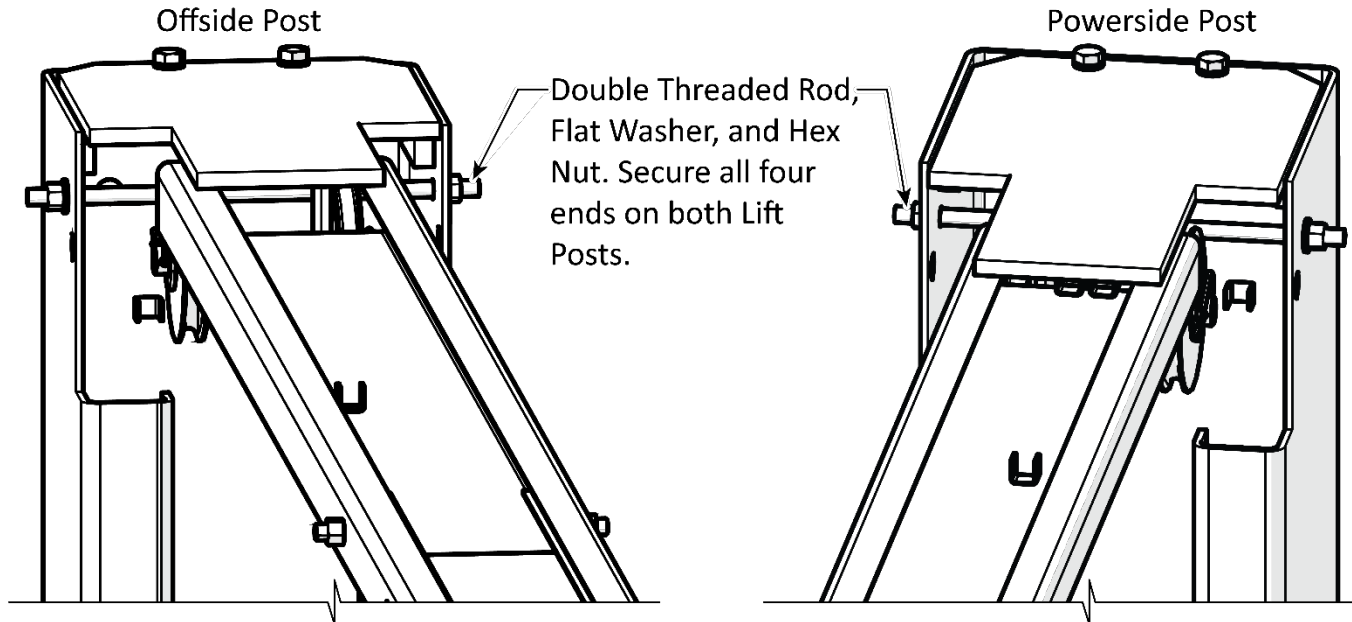

Leveling

Before operating your Lift, verify the Lift Posts are straight up and down (plumb), and the Lift Arms are level:

- **Lift Posts:** The Posts **must** be the same distance apart at the top and at the bottom.

To verify the Posts are straight, measure the distance between the two Posts six inches below the Overhead Assembly and one foot off the ground (you will need to move the Lift Arms out of the way). The two measurements (**A** and **B** in the drawing below) must be the same.

If the Posts are not straight, shim them as required.

- **CAUTION** If your Lift Posts are not plumb or your Lift Arms are not level, this is a safety risk. The Vehicles you place on the Lift will be less secure; they could fall and cause injuries or damage to the Vehicle or to the Lift.

- **Lift Arms:** When the Lift Posts are plumb, verify the Lift Arms are level. Raise the arms to the first locking position and place a level across the Pads.

Adjust the Equalizing Cables to level the Lift Arms. Determine which Lift Arm is low, then adjust the Nut on the bottom of the Threaded End of the Equalizing Cable until the Lift Arms are level. When you believe the Lift Arms to be level, raise the Lift and listen for the Lift Heads hitting the Safety Locks (there is a distinct thump). The thumps to be simultaneous or close to it.

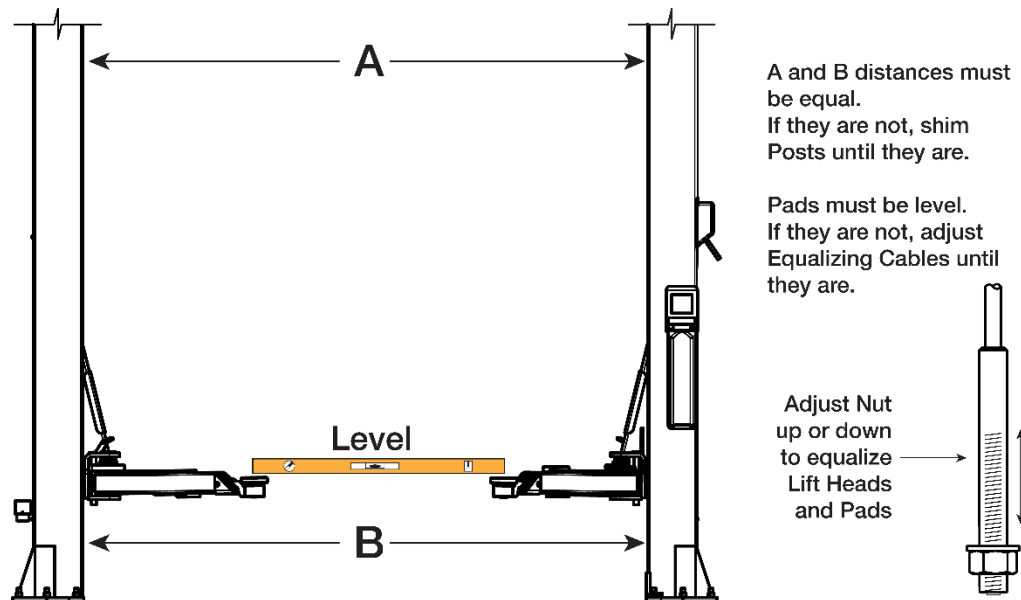

NOTICE

If you have **not** yet torqued the Anchors you can torque them to specification (85 – 95 ft lb.) once you have completed final leveling.

Contact the Electrician

As mentioned previously, there are installation tasks that require a certified Electrician.

⚠ DANGER All wiring **must** be performed by a licensed Electrician in accordance with all applicable local electrical codes.

The Electrician needs to:

- **Connect to power.** The Power Unit comes with a pigtail for wiring to a power source. Have your Electrician connect a power cord with plug to the electrical box on the Lift (for connection to a power outlet) or have them wire it directly into the electrical system at the Lift location.
- **Connect the overhead limit switch to the Power Unit.** The overhead limit switch (which is next to the Safety Shutoff Bar) must be wired to the Power Unit. The necessary wiring is included.
- **Install a Power Disconnect Switch.** Ensures you can quickly and completely interrupt electrical power to the Lift in the event of an electrical circuit fault, emergency, or when equipment is undergoing service or maintenance. You must put it within sight and easy reach of the Lift operator. Refer to **Installing a Power Disconnect Switch** for more information.
- **Install a Thermal Disconnect Switch**, if required by local electrical code. Refer to **Installing a Thermal Disconnect Switch** for more information.

These installation tasks are described in detail in the following sections.

The Electrician is responsible for providing:

- A power cord and appropriate 220 VAC plug for connecting to an appropriate power source or the items required to connect to the facility's power system
- a Power Disconnect Switch
- a Thermal Disconnect Switch (if required by local electrical code).

Additional information is supplied in the following sections describing these tasks.

Electrical Information

⚠ DANGER All wiring **must** be performed by a licensed Electrician in accordance with all applicable national and local electrical codes. Do not perform any maintenance until main electrical power has been disconnected from the Lift and cannot be re-energized until all procedures are complete.

Important electrical information:

- Improper electrical installation can damage the Power Unit motor, which is not covered by the warranty.
- The Lift uses electrical energy; if your organization has Lockout/Tagout policies, make sure to implement them after connecting to a power source.
- Use a separate circuit breaker for each Power Unit.
- Protect each circuit with a time delay fuse or circuit breaker:
 - For a 208 to 230 VAC, **single phase** circuit, protected by a 30 Amp time delay fuse or circuit breaker for the 5585685 power unit delivered with the Lift.

Wiring the Overhead Limit Switch

This section describes how to wire the overhead limit switch; *installing* the overhead limit switch was described in [Installing the Overhead Assembly and Safety Shutoff Bar](#).

The Lift comes with either one or two overhead limit switches, depending on the Power Unit:

- **Single Phase Power Units.** One overhead limit switch is required, which must be wired between incoming power and the Electrical Box on the Power Unit on one of the two “hot” wires.
- **Three Phase Power Units.** Two overhead limit switches are required, which must be wired between incoming power and the Electrical Box on the Power Unit on two of the three hot wires. Both overhead limit switches you receive are identical. If wiring *two* overhead limit switches, they **must** be wired on two **different** hot legs. **For Three-Phase Installations see [Three-Phase Limit Switches Installation](#).**

Refer to the diagrams in [Wiring Diagrams](#) for detailed overhead limit switch wiring information.

The following procedure assumes the overhead limit switch is already in place. If it is not, refer to [Installing the Overhead Assembly and Safety Shutoff Bar](#) to install it.

To wire an overhead limit switch to the Lift:

1. Locate the overhead limit switch and cable supplied with the Lift.
2. **On the Overhead Assembly**, connect two wires of the 14/2 Electrical Cable to the normally closed terminals (NC) of the Limit Switch. For 3 Phase installations, two Limit switches are wired to interrupt two legs of the incoming 3-phase power. Refer to [Wiring Diagrams](#) for wiring information.
3. Verify the Limit Switch Cable is routed correctly. The Cable should be secured in the clips on the overhead assembly and inside the power side lift post. These clips will keep the cable clear of the lift head and equalizing cables.
4. **On the Power Unit**, open the Electrical Box install an appropriate wire connector and wire the overhead limit switch as per the instructions in [Connecting the Power Unit](#).

Connect the Power Unit

The Power Unit and the overhead limit switch must be connected to an appropriate power source.

 **DANGER** All wiring **must** be performed by a licensed Electrician. Do not perform any maintenance or installation on the Lift without first verifying that main electrical power has been disconnected from the Lift and cannot be re-energized until all procedures are complete. This Lift uses electrical energy; if your organization has Lockout/Tagout policies, make sure to implement them after connecting to a power source.

 **DANGER** Make clear to the Electrician that all electrical work **must** conform to applicable local, state, and federal codes, rules, and regulations, such as state and federal OSHA regulations and electrical codes.

The 16AP or 20AP Series Lift is provided with the following Power Unit:

- **208 - 230 VAC, 50/60 Hz, 1 Phase, 5 HP at 23 Amps.**

NOTICE 110 VAC Power Units are currently **not** available for the 16AP or 20AP Series Lifts.

To install Three-Phase Power units see [Three Phase Power Unit Wiring](#).

The figure below is a front view of a standard Power Unit. Your specific Power Unit may look somewhat different based on the type specified and delivered.

Note: The **Up** Button shown in the drawing above could be in a different location on the unit or could be a switch instead of a button, depending on the Power Unit you have.





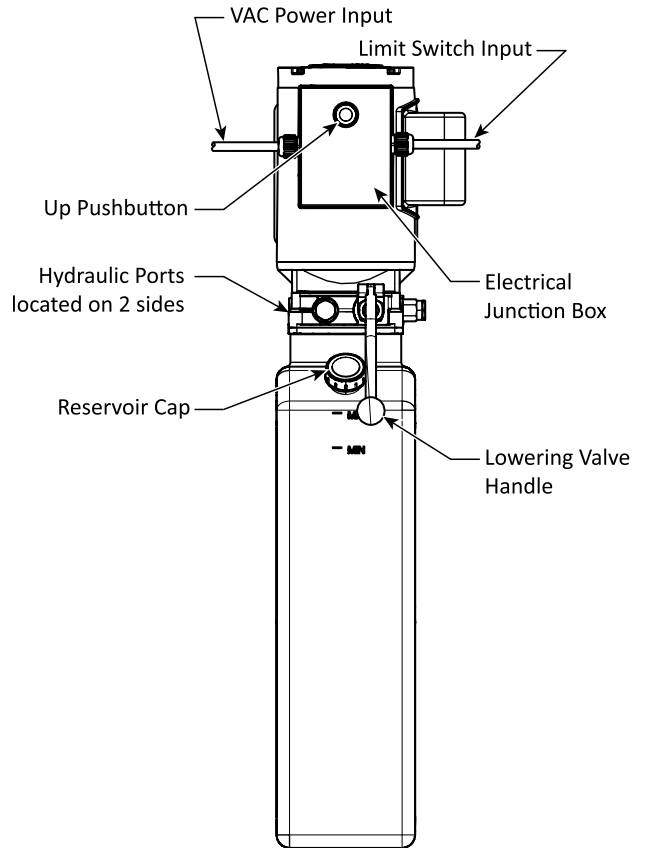





⚠ DANGER Make clear to your Electrician that all electrical work **must** conform to applicable local, state, and federal codes, rules, and regulations, such as state and federal OSHA regulations and electrical codes.

NOTICE Wiring information is either on the outside of the Power Unit under the Electrical Box or inside the cover of the Electrical Box. Have the Electrician use that wiring information to wire the Power Unit to the power source.



Hydraulic System Warnings

Before applying power to the Hydraulic System note the following Warnings:

-  **DANGER** The Hydraulic System may contain high pressure which, if suddenly released, can cause severe injury or death.
-  **DANGER** Failure to observe these warnings can result in serious personal injury including, in rare cases, death.
-  **WARNING** The Hydraulic hoses and connections **must** be inspected before any attempt to raise a Vehicle is made.
-  **WARNING** Verify all Hydraulic Hose connections and fittings, including unused auxiliary port plugs on the Power Unit, the Cylinders and anywhere else in the Hydraulic System are tightened.
-  **WARNING** The Power Unit is a Hydraulic Pump capable of developing pressures in excess of 5,000 psi (345 BAR). A pressure relief valve is used to set the pressure at the desired level. Tampering with, adjusting, modifying, or removing the relief valve is extremely dangerous and is not permitted. Only trained Hydraulics technicians are allowed to adjust the relief valve, using calibrated hydraulic pressure gauges to ensure the proper pressure setting is achieved.
-  **WARNING** Changes to the output pressure may render the power unit incompatible with pressure limitations of other components in the hydraulic circuit. This may cause catastrophic failure of those components, and could result in property damage, serious personal injury, or death.
-  **WARNING** Do **not** attempt to connect or disconnect Hydraulic Hoses while the equipment is loaded or while a Vehicle is on the Lift, or the Hydraulic System is under pressure.
-  **WARNING** Keep bare hands away from Hydraulic Fluid; always wear gloves when handling Hydraulic Fluid, Cylinders or Hydraulic Hoses.
-  **WARNING** When handling Hydraulic Fluid, always observe the safety instructions from the manufacturer.
-  **WARNING** **Always** promptly clean any Hydraulic Fluid spills. If a leak is the source of the spill, lockout the Lift to prevent use until the Hydraulic System is repaired.

To prepare the Power Unit:

1. Have the Electrician locate the Pigtail exiting the electrical junction box on the Power Unit.
2. Open the Electrical Box, remove the Pigtail, and then either:
 - a. Wire the Power Unit directly into the facility's electrical system protected by an appropriate circuit breaker.
 - b. Wire a power cord (with appropriate plug) to the wiring that was connected to the Pigtail.
3. Wire the overhead limit switch(es) into the incoming power. Refer to **Wiring Diagrams** for wiring information.

4. Fill the Hydraulic Fluid reservoir with approved Hydraulic Fluid.

The reservoir holds **≈3.5 gallons** of Hydraulic Fluid, depending on which Power Unit you have.

Approved Hydraulic Fluids are any general-purpose ISO-32, ISO-46, or ISO-68 hydraulic oil or approved automatic transmission fluids such as Dexron III, Dexron VI, Mercon V, Mercon LV, Shell Tellus S4 / S3 / S2, or any synthetic multi-vehicle automatic transmission fluid.

⚠ WARNING Do not run the Power Unit without Hydraulic Fluid; you will damage it.

⚠ DANGER **Risk of explosion:** This equipment has internal arcing or parts that may spark and should not be exposed to flammable vapors. The Power Unit's motor should not be located in a recessed area or below floor level. Always install a minimum of 18 in. (457 mm) above the floor. Never expose the motor to rain or other damp environments; damage to the motor caused by water is not covered by the warranty.

Install the Power Disconnect Switch

⚠ WARNING A Power Disconnect Switch is **not** provided with this equipment.

A Power Disconnect Switch is a National Electrical Code (NEC) requirement. They are designed to allow the operator to interrupt the main electrical power in the event of an emergency or circuit fault, or when the equipment is undergoing service or maintenance.

Make sure to install a Power Disconnect Switch that is properly rated for the incoming power source.

Your Power Disconnect Switch must be readily accessible and installed so that it is in easy reach of the operator or in their line of sight. The Power Disconnect Switch must be clearly marked to indicate its purpose.

The figure to the right details a Power Disconnect Switch located between the Lift's power source and its Power Unit. A quick flip of the switch immediately cuts power to the Lift.

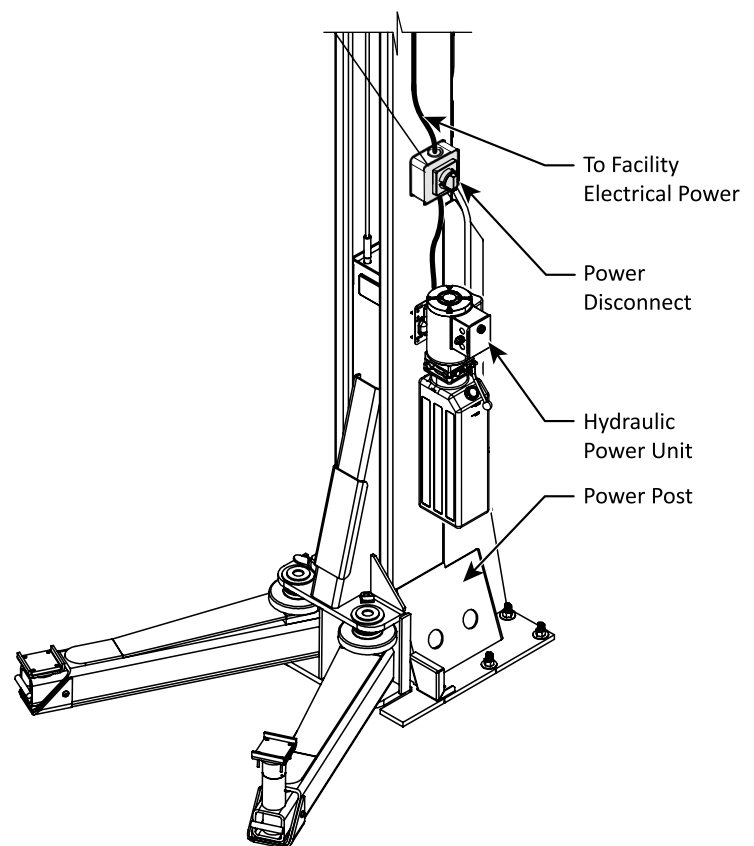

⚠ DANGER Installing a Power Disconnect Switch **must** be performed by a licensed Electrician in accordance with local, state, and national electrical codes.

Have the Electrician select a **UL-listed** Power Disconnect Switch. Running high electrical current that exceeds the motor's full load amperage (FLA) rating may result in permanent damage to the motor. BendPak strongly recommends you **not** exceed the rated duty cycle of the Lift motor.

Installing a Thermal Disconnect Switch

The Power Unit supplied with this Lift **does not** include thermal overload protection. Under NEC 430, UL 201, and CSA C22.2 No. 68 intermittent duty motors are not required to include thermal protection. Local electrical codes may vary, and other requirements may exist that the installing electrician will address, if required.

⚠ DANGER If local Electrical codes require the installation of a Thermal Disconnect, the disconnecting device and the installation **must** be provided by a licensed Electrician in accordance with local electrical codes. Do not perform **any** maintenance or installation on the Lift without first verifying that main electrical power has been disconnected from the Lift and **cannot** be re-energized until all procedures are complete.

Lubricate the Lift

Lubricate the following with a white lithium grease or similar:

- All Cable Sheaves and Cable Sheave Pins on both Posts.
- The four inside corners of both Posts
- All Safety Sheaves
- All Lift Arm Pivot Points

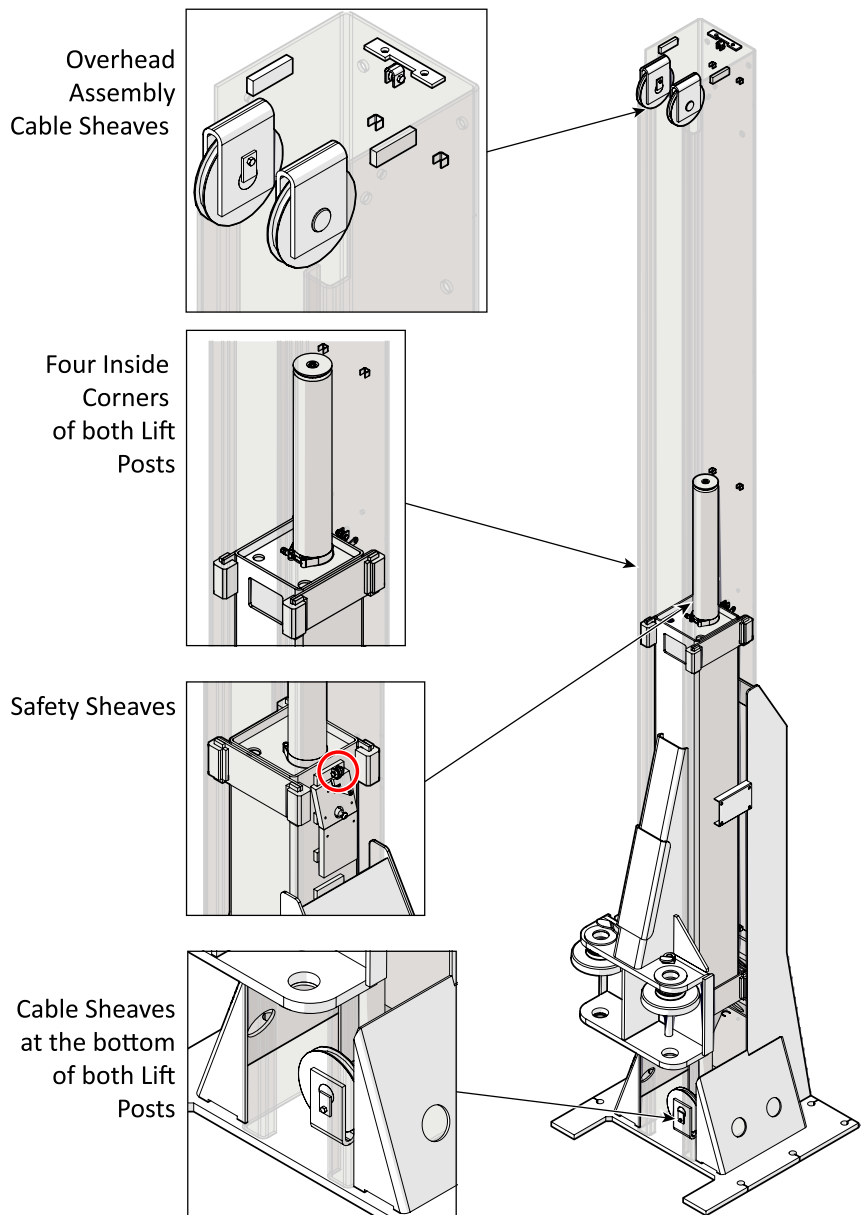

Review Final Checklist Before Operation

Verify these items have been completed before putting the Lift into normal operation:

- Review the **Installation Checklist** and verify all steps have been performed.
- Make sure the Power Unit is receiving power from the power source.
- Check the Hydraulic Fluid reservoir; it must be full of approved Hydraulic Fluid or automatic transmission fluid. **You can harm the motor by running it without enough fluid.**
- Check the Hydraulic System for leaks. Verify all Hydraulic Hose connections, Hydraulic Fittings, and Auxiliary Port Plugs on the Lift and Power Unit are tight.
- Verify both Posts are properly plumbed, shimmed, and stable.
- Check to see that all Anchor Bolts are correctly torqued.
- Lubricate all Cable Sheaves and the inside of the Posts where the Slide Blocks travel.
- Verify both Double Threaded Rods are in place and tightened near the top of both Posts.
- Make sure all Cables are properly positioned in their Sheaves.
- Make sure all Cable Sheave retaining pins and/or fasteners are secure.
- Make sure both Safety Assemblies are connected and engaging/disengaging normally.
- Verify both Cylinder Clamps are secured in place on the Hydraulic Cylinders above the Lift Head.
- Make sure that all Safety Locks are clear and free.
- Make sure an Operational Test has been performed.

Perform an Operational Test

Before putting your Lift into normal operation, BendPak recommends raising and lowering it several times with a typical Vehicle on the Lift. This will help you get a feel for how to operate the controls and help get any residual air out of the Hydraulic System (sometimes called “bleeding” the system).

⚠ DANGER Automotive Lifts are dangerous tools when used by inexperienced or impaired technicians. When you even hear the words “automotive lift,” your brain should automatically register the fact that lifting a Vehicle is a serious endeavor with life-threatening risks if mandatory lifting precautions are ignored.

During the Operational Test, check for proper installation and operation. Do not raise any additional Vehicles until a thorough Operational Test has been completed with a typical Vehicle.

⚠ WARNING Never raise a Vehicle whose weight exceeds the rated capacity of the Lift. Do not leave the controls until the Lift is engaged on its Safety Locks. Only trained personnel should raise or lower the Lift.

To perform an Operational Test:

1. Make sure you have covered all the areas in **Review Final Checklist before Operation** before proceeding further.
2. Follow the instructions in **Raising a Vehicle** and **Lowering a Vehicle** to safely raise and lower a Vehicle on the Lift.

⚠ DANGER Follow the instructions carefully when it comes to contacting the manufacturer’s recommended Lifting Points on the underside of the Vehicle. If you do not, the Vehicle could become unstable and fall, which could damage the Vehicle, damage the Lift, and injure or even kill anyone under the Vehicle.

-
- Adjust the Lift Arms under the Vehicle so the Lift Pads are directly under the Lifting Points for the Vehicle you are raising. If necessary, use Auxiliary Adapters (**see Optional Accessories**) for additional height.
 - Press the **Up** button to raise the Lift until **just before** the Lift Pads contact the Lifting Points.
 - Check the Arm Restraint Gears on all four Lift Arm Assemblies to verify they are engaged. If they are not engaged, move the Lift Arms back and forth until they engage.
 - Raise the Lift until the tires of the Vehicle are a few inches off the ground.
 - Verify all four Lift Pads are making solid contact with all four Lifting Points.

If any of the Lift Pads are **not** making solid contact with the Lifting Points, carefully lower the Lift and begin again; the Lift Pads **must** make solid contact with all Vehicle Lifting Points.

- Raise the Vehicle approximately three feet off the ground, then release the **Up** button, then *press and hold* the Safety Lock Release Handle and the Lowering Handle to lower the Lift back down.

NOTICE

Residual air in the Hydraulic System can cause the Lift to shake, move erratically, or squeak; this is normal during the initial Lifts. The Lift will soon stop doing this, as the Hydraulic System self-bleeds.

- Wait for one minute.

⚠ WARNING

The Power Unit is not a constant duty motor; **it cannot be run continuously.**

- Repeat the process, this time raising the Lift, engaging it on a Safety Lock position, taking it off the Safety Lock position, and then lowering it back down to the ground.
- If the Lift is working without shaking, moving erratically, or squeaking, there is no need to repeat the procedure. If the Lift is shaking, moving erratically, or squeaking, repeat the procedure one more time. If you continue to have issues, refer to **Troubleshooting** for assistance.
- When the Lift is on the ground and the Vehicle is on all four tires, move the four Lift Arms to their full drive-through positions, then drive the Vehicle out.
- With no Vehicle on the Lift Arms, press and hold the **Up** button on the Power Unit.
- Have another person push up the Safety Shutoff Bar until it triggers the overhead limit switch.

If the Lift Arms do not stop rising when the overhead limit switch is triggered, the overhead limit switch is either not installed correctly or not wired correctly. Return to the sections in this manual where installation and wiring of the overhead limit switch is described to identify and correct the issue.

⚠ CAUTION

Do not put the Lift into normal operation until you have confirmed that triggering the overhead limit switch stops the Lift Arms from rising.

Leave the Manual with the Owner/Operator

Leave the *Installation and Operation Manual* with the owner/operator so that it is available to everyone who will use the Lift.



Operation

This section describes how to operate your BendPak 16AP and 20AP Series Lift.

 **DANGER** Automotive Lifts are dangerous tools when used by inexperienced or impaired technicians. When you even hear the words “automotive lift,” your brain should automatically register the fact that lifting a Vehicle is a serious endeavor with life-threatening risks if mandatory lifting precautions are ignored.

Lift Operation Safety Rules

 **DANGER** Your safety depends on reading, understanding, and implementing these Safety Rules. Do not skip over them; read them carefully and follow them!

Do the following **before** you raise or lower a Vehicle on your Lift:

Check the Lift. A complete inspection of the Lift is required before using it. Check the Hydraulic System for loose connections including Hydraulic Fittings, Hydraulic Hoses, and any Auxiliary Port Plugs. Check the Lift for any missing, heavily worn, or damaged parts. Do not operate the Lift if you find any issues; instead, take it out of service, contact your dealer, email support@bendpak.com, or call **(800) 253-2363**, option 7, then 4.

- **Check the area.** Keep the area around the Lift clean and free of obstructions; anything that could obstruct the Lift. Do not forget to check **above** the Lift. If you find an obstruction, move it out of the way. Do not allow any people or animals within 30 feet of the Lift while it is in motion.
- **Check the operators.** Make sure that everyone who is going to operate the Lift has been trained in its use, has read the labels on the unit, and has thoroughly read the manual and understands how this equipment works. Only the operator should be within 30 feet of the Lift when it is in motion. Do not allow children to operate the Lift. Do not allow anyone under the influence of drugs or alcohol to operate the Lift.
- **Check for safety.** Make sure everyone who is going to be walking near the Lift is aware of its presence and takes appropriate safety measures. Only put Vehicles on the Lift Arms. **When raising a Vehicle on the Lift, do not leave it until it is positioned on Safety Locks.** When lowering the Lift, do not leave it until it is on the ground.
- **Check the Vehicle.** Never exceed the Lift’s weight rating. Do not allow people inside a Vehicle you are going to raise. Make sure the Vehicle is not overbalanced on either end. Make sure you know the manufacturer’s recommended Lifting Points for the Vehicle. Never raise just one side, one corner, or one end of a Vehicle.

 **WARNING** Always use care when you are around your Lift. When it is in a lowered position, be careful not to trip over it. When it is raised, be careful not to hit your head on the Lift Arms or the Vehicle. **When you are raising or lowering a Vehicle, keep all people, animals, and objects at least 30 feet away from the Lift.**

 **WARNING** Never place yourself or others under a raised Vehicle unless the Lift is engaged on its Safety Locks and the Vehicle is stable on the Lift. Always use Jack Stands to secure the Vehicle when work is under way or if removing components that will significantly change the Vehicle’s balance on the Lift.

About Lifting Points, Adapters, and Auxiliary Adapters

An important point to keep in mind when using a frame-engaging Lift is that the raised vehicle must be balanced on the four Lift Arms. If the Vehicle is not balanced, it is more likely to become unstable and slide off the Lift, possibly damaging the Lift, the Vehicle, and anything under the Lift, including injuring people.

⚠ WARNING You **must** use all four Lift Arms when raising a Vehicle. Never use just one, two, or three Lift Arms to raise a Vehicle. The Vehicle will be unstable and could slip off the Lift, possibly damaging the Lift, damaging the Vehicle, and injuring anyone under it.

To balance a Vehicle on a frame-engaging Lift, the Lift Pads (adapters) must contact the vehicle on the manufacturer's recommended Lifting Points. When you raise a vehicle by its lifting points, the vehicle is balanced.

NOTICE The manufacturer's recommended Lifting Points do not take into consideration any major changes that might have been made to the Vehicle. If the motor is removed, for instance, or there is a 5,000 pound / 2,268 kg weight in the trunk, the Vehicle's Lifting Points will not be the best balancing points.

Some Vehicles have indicators on the underside that identify the manufacturer's Lifting Points; many do not.

Your best approach is to find the Vehicle in the guide provided with your Lift. *Vehicle Lifting Points for Frame Engaging Lifts* or contact the manufacturer of the Vehicle. This guide also includes a page of safe lifting suggestions, which everyone who uses the Lift should read.

Lifting it Right: A Safety Manual from the Automotive Lift Institute, also provided with your Lift, includes a wide variety of information about Lifts and how to use them safely.

⚠ DANGER **Never** place Contact Pads on non-approved, non-load holding Sill Covers or Side Skirts!

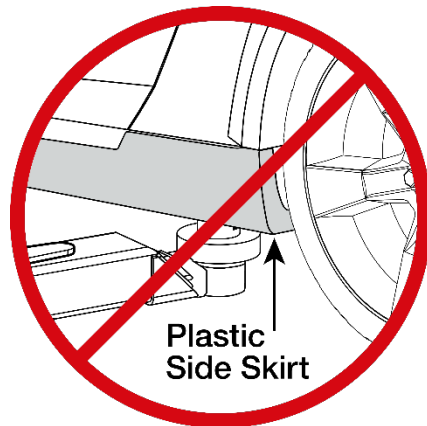

Standard Accessories

The 16AP and 20AP are supplied with:

- **Four Drop-In Frame Cradle Pads** (5215761) Best suited for lifting trucks, vans or other frame Vehicles that require additional stability. Set of 4.

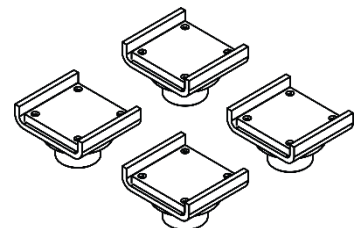

- **Four Medium Auxiliary Adapters - 2.5 in. (63 mm)** (5746192). Allows you to position the height of Pads to make better contact with vehicle on the Lift.
- **Four Tall Auxiliary Adapters - 5 in. (125 mm)** (5746193). Allows you to position the height of Pads to make better contact with vehicle on the Lift.

Optional Accessories *(Not included with the Lift)*

- **Four Tall Auxiliary Adapters – 5.00 in. (125 mm)** (5746193). Allows you to position the height of the Auxiliary Adapters to make better contact with Vehicles. (Set of 4 sold separately)
- **Four Medium Auxiliary Adapters – 2.50 in. (63 mm)** (5746192). Allows positioning the height of the Auxiliary Adapters to optimize contact with Vehicles. (Set of 4 sold separately)

⚠ WARNING You can stack Auxiliary Adapters, but only up to 9 in. If you stack Auxiliary Adapters above 9 in., the Vehicle could become unstable and slip off the Lift, possibly damaging the Lift, damaging the Vehicle, and injuring anyone under it.

- **SUV and Van Adapters** — Recommended for Trucks, SUVs, and Vans requiring additional lifting height.

56 mm (5746007)

63 mm (5746192)

125 mm (5746193)

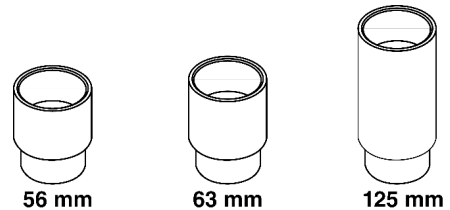

⚠ WARNING Use the correct Adapters. Do not attempt to lift trucks or other frame type vehicles with standard Rubber Contact Pads.

- **Wide Frame and Super Wide Frame Cradle Adapters** — Recommended for use when lifting heavy-duty wide frame vehicles.
 - **Wide Frame** version fits frames up to 5.25 in. (133 mm) (5215848) wide, Set of 2.
 - **Super Wide Frame** version fits frames up to 6.5 in. (168 mm) (5210253) wide, set of 2.

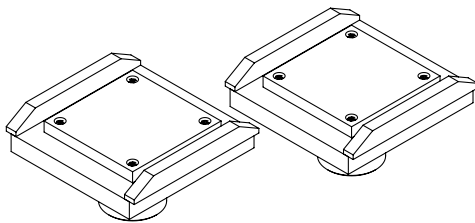

Wide Frame Cradle Adapter

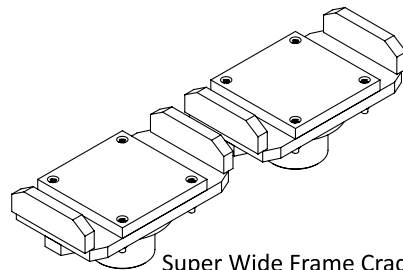

Super Wide Frame Cradle Adapter

- **Cradle Lift Pad** — Wide Polyurethane Pad, set of 4 pads (5210231).

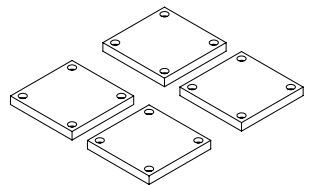

-
- **Steel Lift Pads** — Recommended for additional stability on all vehicles. The flanged edges grip the chassis for an extra-secure hold. (5215692)

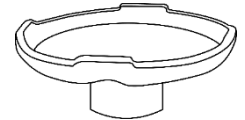

You may contact BendPak for accessories and replacement Parts information at **(800) 253-2363**, press option 7, then 5; please have the model and serial number of your Lift available. Visit [bendpak.com](https://www.bendpak.com) for additional Adapters and Auxiliary Adapters (also called height adapters or extenders).

Raising a Vehicle

This section describes how to raise a Vehicle on the AP Series Two-Post Lift.

⚠ WARNING Never raise a Vehicle whose weight exceeds the rated capacity of the Lift. Do not leave the controls until the Lift is engaged on a Safety Lock position or fully lowered. Only trained personnel should raise and lower the Lift.

⚠ WARNING Always stay within the Safe Operator Area when using the Lift. Refer to the figure below. The safe operator area will keep the operator clear of crushing, shear and pinch points while providing an unobstructed line of sight to the vehicle and access to the Lift Controls. Personnel near the Lift but outside of the Safe Operator Area should be moved clear of the lift by a minimum of 30 ft. (9 m).

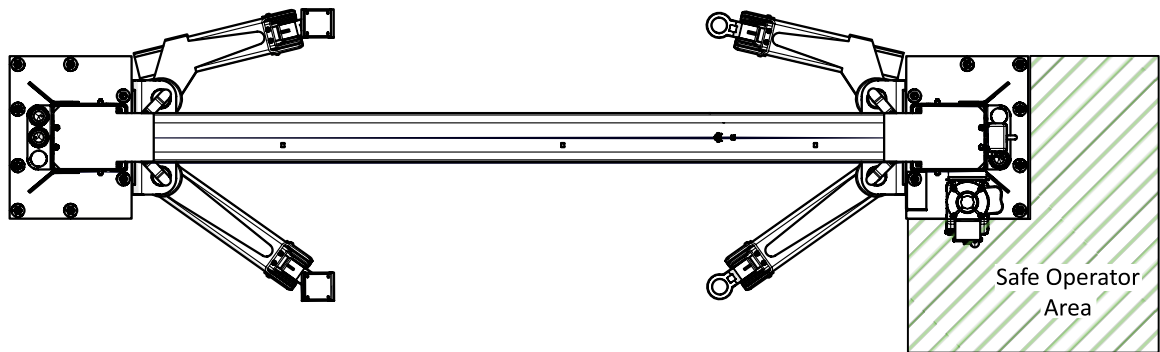

To raise a Vehicle:

1. Verify all four Lift Arms are on the ground in their full drive-through positions and all personnel are clear of the service bay.
2. Check under the Vehicle to be raised, check for the type of vehicle frame, and then put the most appropriate Pads/Adapters on the Lift Arms. If you are lifting a sedan or a Vehicle with a unibody construction, a Screw Lift Pad is generally the best choice. If you are lifting an SUV, truck, or other Vehicle with a frame construction, a Frame Cradle Pad is generally the best choice.

⚠ WARNING Always use the Pad/Adapter type best suited for the Vehicle you are raising. If you use the wrong Adapter type, the Vehicle could become unstable on the Lift.

3. Drive the Vehicle into the service bay.

⚠ CAUTION When driving a Vehicle into position, keep to the middle of the area between the Posts. If you hit a Lift Arm or any other portion of the Lift, you could damage the Vehicle and/or the Lift.

4. When you are satisfied with the location of the Vehicle, put it in park, engage the parking brake, and turn off the motor. If the Vehicle is a manual transmission, put it into first gear before turning off the motor.
5. Driver and all passengers must exit the Vehicle prior to operating the Lift. Open the doors carefully.
6. Locate the manufacturer's recommended Lifting Points for the Vehicle you are raising. If you are unsure where the Lifting Points are, consult *Vehicle Lifting Points for Frame Engaging Lifts*, which is provided with the Lift, or the manufacturer of the Vehicle. To order additional copies, contact ALI or BendPak Support email support@bendpak.com or call **(800) 253-2363**, press option 7, then 4.

Some Vehicles may have the manufacturers' recommended Service Garage Lift Point locations identified by a triangle mark on the underside of the Vehicle, reference SAE J2184- (Current Edition). On some Vehicles, specific Lifting Points are indicated by a label located on the driver's side door jamb.

⚠ WARNING Do not 'eyeball' the best location for the Pad/Adapters. **You must use the manufacturer's recommended Lifting Points.** If you do not, the Vehicle could become unstable and fall, damaging the Vehicle, the Lift, and injure or even kill anyone under the Vehicle.

⚠ WARNING Many specialty or modified Vehicles or Vehicles with unusually short or long wheelbases cannot be on raised on a Two-Post Frame Engaging Lift. Contact the Vehicle's manufacturer for Raising or Jacking guidance.

The figure on the next page illustrates typical lifting points based on Vehicle Frame type.

Typical Lifting Points

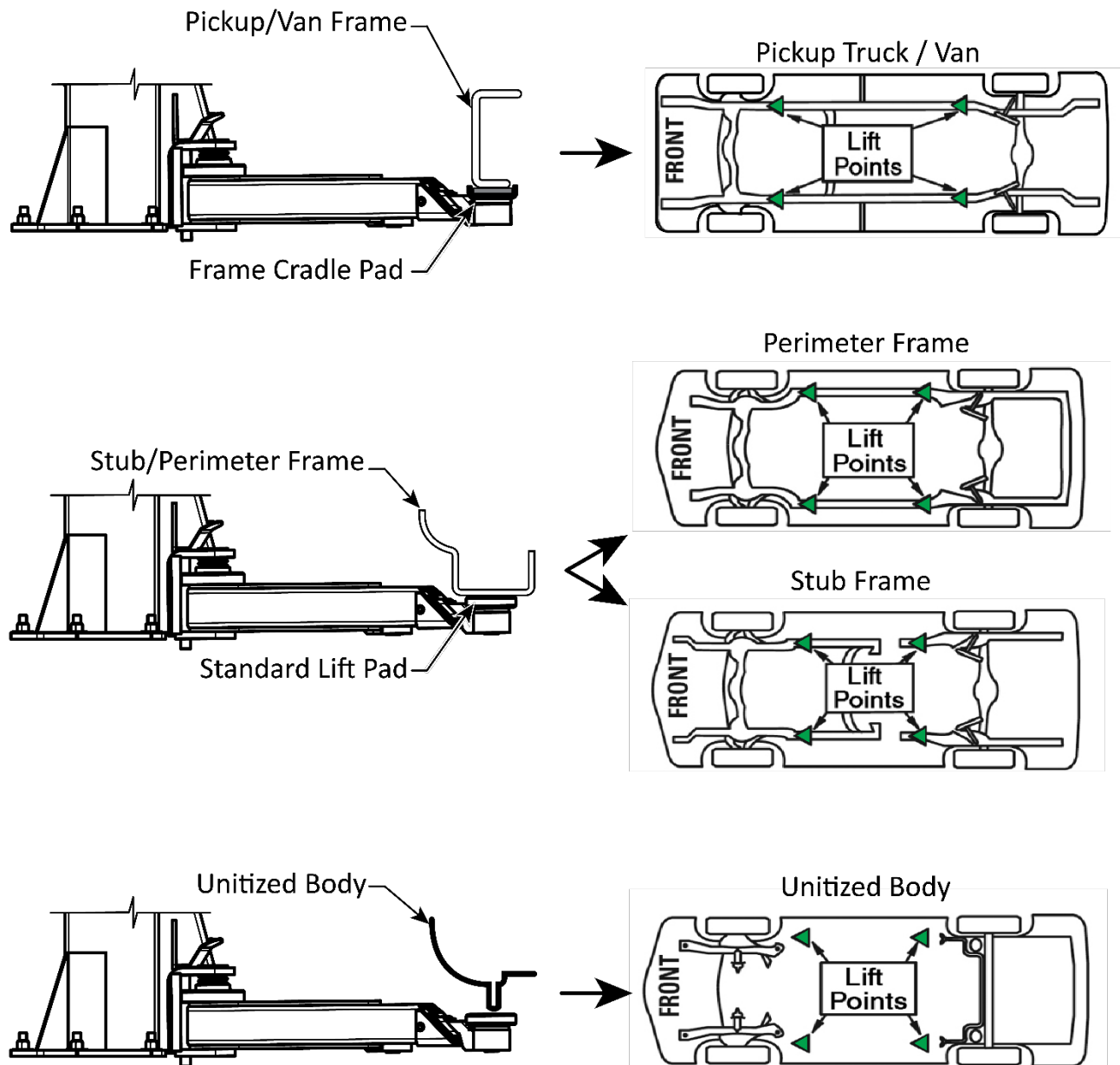

⚠ WARNING Before attempting to lift a vehicle verify:

- The Vehicle Frame is strong enough to support the weight and has not been weakened or compromised by modification, damage, or corrosion.
- The Vehicle individual axle weight does not exceed one-half the Lift capacity.
- All Lift Pads/Adapters are in secure contact with the frame at the vehicle manufacturers' recommended Lift Points.
- The Vehicle is stable on the Lift and the center of gravity has not shifted, making the vehicle off balance.
- The limit switch stop bar will contact the highest point on the vehicle.

⚠ WARNING Always use Safety Stands when removing or installing heavy components that may affect the vehicle's center of gravity.

7. Adjust the lift arms under the vehicle until the pads/adapters are **directly under** the lifting points for the vehicle you are raising. If necessary, use the included auxiliary adapters for extra height. Refer to the figure below.

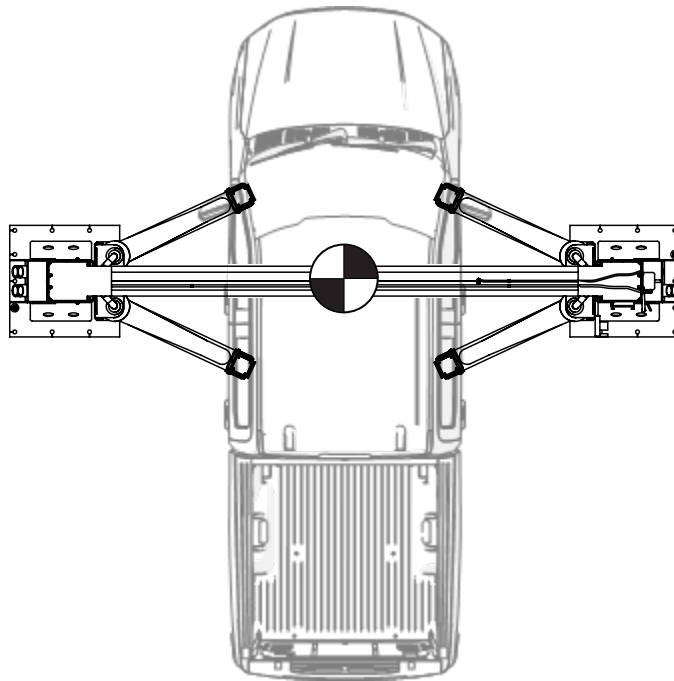

Reference only – do not scale.

8. Raise the Lift until **just before** the pads/adapters contact the lifting points.
9. Check the arm restraint gears on all four lift arms to verify they are engaged.

If they are not engaged, move the lift arms back and forth until they do engage.

10. Raise the Lift until the tires of the vehicle are a few inches off the ground.
11. Verify all four pads/adapters are making solid contact with the lifting points.

If any of the pads/adapters are **not** making solid contact with the lifting points, carefully lower the Lift and begin again; the pads/adapters **must** make solid contact with all lifting points.

12. Gently rock the vehicle to make sure the vehicle is stable and balanced.

- If the vehicle is **not** stable and balanced, lower the Lift back to the ground and start over.
- If the vehicle **is** stable and balanced, you can raise it to the desired height.

 **DANGER** Do not raise the Lift further until you are certain the vehicle on the Lift is both stable and balanced. If the vehicle is **not** stable and balanced, it could fall, which could damage the vehicle, damage the Lift, as well as injure or kill anyone under the vehicle.

 **WARNING** Always keep an unobstructed line of sight to the Lift. Ensure personnel and objects are always clear of the Lift.

 **WARNING** Remain clear of the elevated Lift until visual confirmation is made that all safety locks are fully engaged, and the Lift is lowered onto its Safety Locks.

13. Press and hold the **Up** button.

14. Listen as the Lift passes the safety locks; you should hear a thump as each lift head passes by the safety locks at approximately the same time.

15. When the vehicle reaches the desired height, proceed past the next safety lock position (you will hear the thump as it passes), then release the **Up** button.

16. *Press and hold* the Lowering Handle, which lowers the Lift onto the safety lock position you just passed. Do **not** hold the safety lock release handle, which is for lowering the Lift to the ground.

17. When the Lift stops moving down, it is engaged on its safety locks; release the lowering handle.

Do not leave the Lift controls unless the Lift is engaged on its Safety Locks or fully lowered.

18. Recheck the pads/adapters to make sure they are all still making solid contact with the lifting points.

19. Verify the Lift is engaged on the **same safety lock** on both Posts.

 **DANGER** Always ensure both safety locks are engaged. If the lift heads are engaged on safety locks at two different heights or only one safety lock is engaged, the vehicle could become unbalanced and fall causing damage, injury, or death.

20. Begin work on the Vehicle. Always use safety stands when working under a vehicle.

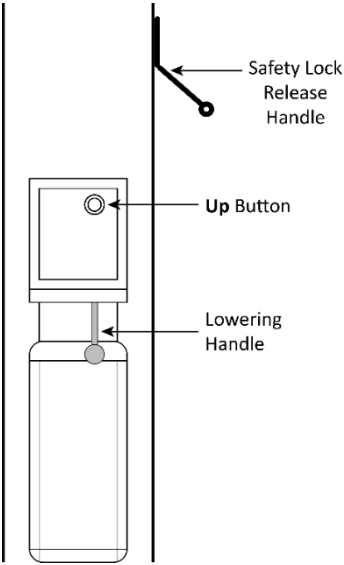
<p>To raise the Lift:</p> <ol style="list-style-type: none"> 1. Press and hold Up Button. 2. When Lift is just past desired height, release Up Button. 3. Press and hold Lowering Handle. <p><i>Do not pull down the Safety Lock Release Handle. If you do, the Lift will continue to lower and will not engage on its Safety Locks. Lift engages on its Safety Locks and stops moving; release Lowering Handle when Lift stops.</i></p> <p><i>Only leave the Lift on Safety Locks or fully lowered.</i></p>	 <p>The diagram shows a vertical lift column with three control points. At the top is the Safety Lock Release Handle, which is a lever that can be pulled down. Below it is the Up Button, a circular button. At the bottom is the Lowering Handle, a circular button. Arrows point from the text labels to each of these three components.</p>	<p>To lower the Lift:</p> <ol style="list-style-type: none"> 1. Press and hold Up Button for two to three seconds. This moves Lift off its Safety Locks. 2. Pull down and hold Safety Lock Release Handle and Lowering Handle. Lift begins lowering. 3. When Lift is fully lowered, release Safety Lock Release Handle and Lowering Handle. <p><i>Only leave Lift on Safety Locks or fully lowered.</i></p>
--	---	---

Lowering a Vehicle

To lower a Vehicle off the Lift, first raise it a small amount to get it off its Safety Locks, then lower it.

To lower a Vehicle off the Lift:

1. Check under and around the Vehicle to verify the area is clear of all obstructions.

If you find any obstructions, **move them out of the way.**

2. Press and hold the **Up** Button for a second or two to move the Lift off its Safety Locks.

Raise the Lift at least two inches to clear the Safety Locks.

3. Pull down and hold the Safety Lock Release Handle (on the power side Post above and to the right of the Power Unit).
4. Push and hold the Lowering Handle (on the front of the Power Unit). The Lift begins to lower.

NOTICE

Both the Safety Lock Release Handle **and** the Lowering Handle must be held down at the same time to lower the Lift.

⚠ WARNING

Do not override the Lift controls. For safety purposes, Lift controls are designed to stop the Lift if released. Overriding the Lift controls could lead to damage to the Lift, damage to the Vehicle on the Lift, injury, or in rare cases, death to persons near the Lift.

⚠ CAUTION

Remain clear of the Lift as it lowers; obey the pinch point warning decals.

5. When the Lift is on the ground, release both Handles, then move all four Lift Arms to their full drive-through positions to allow an unobstructed exit for the Vehicle.
6. Carefully drive the Vehicle out.

About Safety Locks

A Safety Lock **position** is defined as when the Lift is engaged on both Lift's Safety Locks at the same height on both Posts. Having multiple Safety Lock positions allows you to lock the Lift at the best height for what you intend to accomplish.

⚠ CAUTION Verify that both Safety Locks are engaged at the same height on both Posts. You do not want the Lift engaged on Safety Locks of two different heights or the Safety Lock on one Post engaged but the Safety Lock on the other Post not engaged.

Safety Lock positions are created by the Safety Lock Weldments, which are on the back of each Lift Head. Safety Lock Weldments hit the Safety Locks and then move past them as the Lift Heads rise.

Passing:

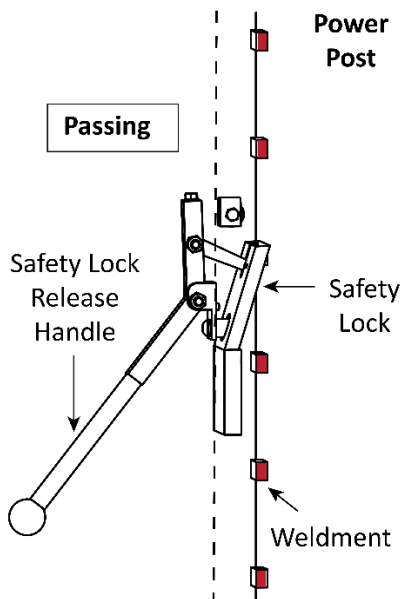

Between Weldments:

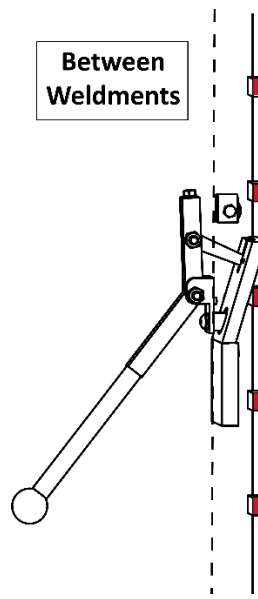

Engaged:

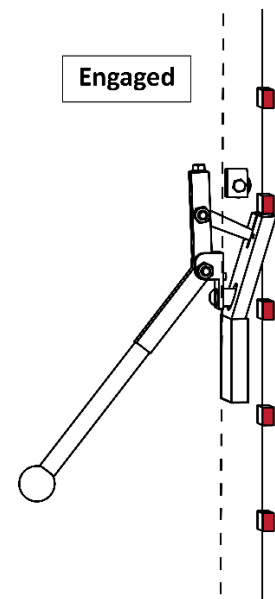





Components removed for clarity. Offside Safety Lock not shown. Reference only – do not scale.

As they move past the Safety Locks, the Weldments push the Safety Lock and the Safety Lock Release Handle down. When the Weldment is completely past the Safety Locks, the Safety Lock Spring pulls the Lock back into place. This happens each time Safety Locks are passed, so you will generally be hearing multiple clanks as the Lift rises and lowers.

To engage the Lift on a Safety Lock position, press the **Up** Button and wait until the Vehicle reaches the desired height for the work you are going to do, then listen for the clank as the Weldments pass the next Safety Lock position. When you hear the clank, release the **Up** Button, and then hold down the Lowering Handle (on the front of the Power Unit) for a second or two to back the Weldments down onto the just-passed Safety Locks; **do not** hold down the Safety Lock Release Handle.

⚠ WARNING Only leave the Lift either fully lowered or engaged on Safety Locks. **If you leave the Lift raised but not engaged on Safety Locks, the Vehicle is not secure.** It could fall, possibly damaging the Vehicle, the Lift, and injuring anyone under the Vehicle.

Maintenance

-  **DANGER** Before performing any maintenance on your Lift, verify it is completely disconnected from power. The Lift uses electrical energy; if your organization has Lockout/Tagout policies, make sure to implement them before performing any maintenance. If you come into contact with high voltage, you could be injured or killed.
-  **DANGER** Do not use the Lift if the cables are damaged or extremely worn. If a Vehicle is raised when you notice the damage or extreme wear, very carefully lower the Vehicle to the ground. When the Lift is on the ground, remove it from service, disconnect it from power, and make arrangements for repair.
-  **DANGER** Always wear proper Personal Protective Equipment (PPE) when working with hydraulics. Gloves and Safety Glasses are a minimum requirement. Keep your body away from suspected leaks. Use a clean piece of sheet metal to pass along hoses and fittings to detect leaks. Shut down the equipment if a leak is suspected or
-  **WARNING** Do not operate your Lift if you find maintenance issues; instead, remove it from service and correct the maintenance issues. Technical support and service is available from your dealer, on the Web at [bendpak.com/support](https://www.bendpak.com/support), by email at support@bendpak.com, or by phone at **(800) 253-2363**, option 7 then 4. Online chat is also available at www.bendpak.com click the chat icon. 

Read the Installation and Operation manual and understand how this equipment operates before using, maintaining, or repairing. Routine maintenance and adjustments are the responsibility of the owner/user and are not covered under warranty.

Routine maintenance and adjustments should be carried out on a regular basis as outlined below. *Unless stated otherwise, all maintenance may be performed by the owner/employer and does not require trained lift service personnel.* Replace worn, damaged or broken parts with original BendPak or BendPak approved parts or with parts that meet or exceed the original specifications.

Maintenance and Interval Recommendations:

This lift's service life is dependent on the level and frequency of care and maintenance you provide. By simply following a few guidelines, you can increase the life of your lift by many years. The following care and maintenance procedures not only help to foster that, but also aid by ensuring safe operation and early detection of problems.

Tools required:

- Open End Wrench Set
- Screwdrivers (Phillips and slotted)
- Hydraulic Fluid (same type and weight as the current fluid in use.)
- Clean shop towels
- Hex Key Set
- Lubricants
 - White Lithium Multi-Purpose Lubricant
 - Red Lithium Grease
 - ALMASOL Wire Rope Lubricant or 90W Gear Oil

The following maintenance and interval recommendations are based on typical workday use and operation.

Daily Maintenance

1. Keep the Lift and work area clean, to promote both safety and better problem visibility.
2. Visually inspect that the Safety Locks are in good operating condition. Do not use your Lift if the Safety Locks are damaged or excessively worn.
3. Check the Hydraulic Fluid Level in the Reservoir. Add fluid, if necessary.
4. Check for hydraulic fluid leaks on hoses, fittings, and cylinders. Inspect for damage. Hose covers that are cut, cracked, blistered, show signs of abrasion, kinking or flattened are to be replaced. Cylinder ports that are cracked, show signs of leaking or other damage.
5. Start the hydraulic system and pass a clean piece of sheet metal near the hydraulic hoses, fittings, and cylinders. Hydraulic fluid on the metal indicates a leak. Shut down the system and tagout the Lift to prevent use until repaired.
6. Verify the cylinder clamp is in place and tight on the hydraulic cylinder just above the Lift head.

Monthly Maintenance

1. Remove, clean, and apply new Red Lithium grease to all Cable Sheave Pins as outlined in the Lubrication Procedure.
2. Inspect the condition of all Equalizing Cables and mechanisms. Run a shop towel over the Cable surface while watching for snags. Replace as required.
3. Inspect all hydraulic hoses, fittings, and cylinders for damage and leaks.
4. Apply 90-WT gear oil or ALMASOL® Wire Rope Lubricant to both Equalizing Cables.
5. Apply White Spray Lithium MP grease to the four inside contact corners of both Posts.
6. Apply White Spray Lithium MP grease to all Lift Arm Pivot Points.
7. Inspect all Lift Arm Pins and locking mechanisms for damage and wear. Replace as required.
8. Verify all fasteners are torqued to specifications.
9. Verify all Warning labels are in good condition and legible.

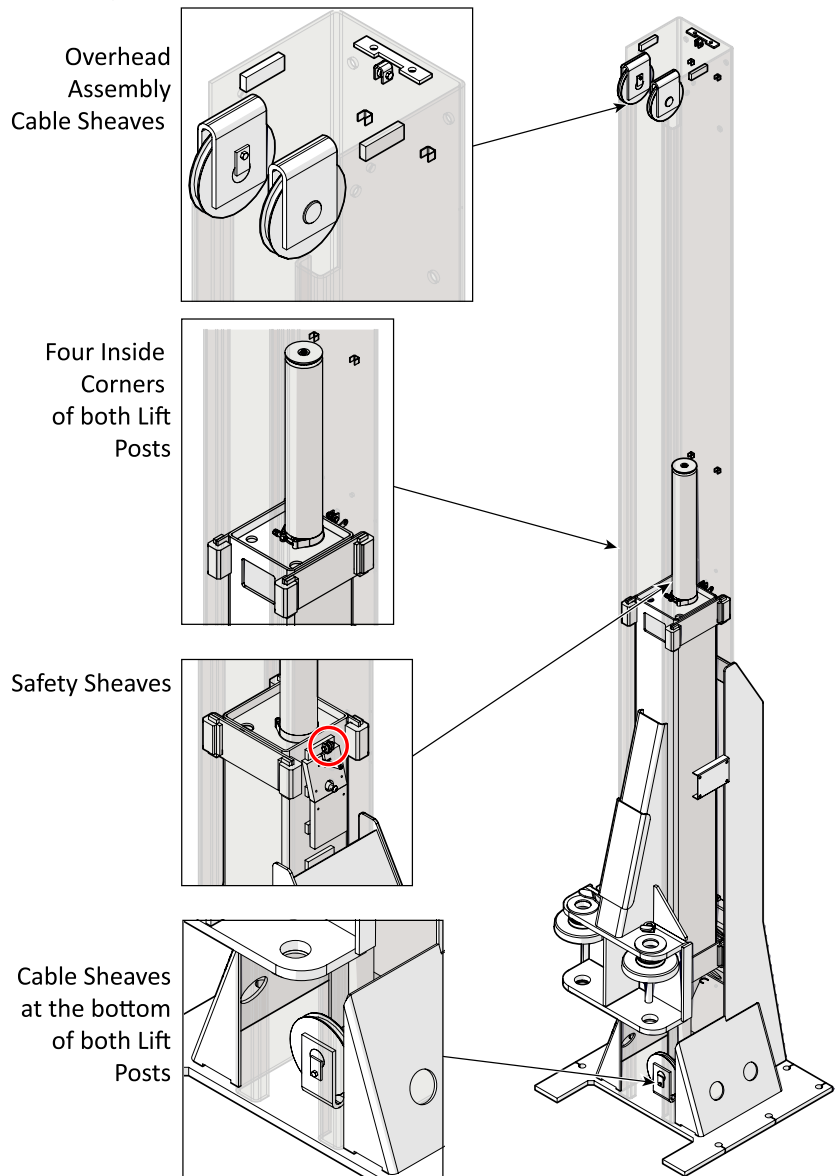

Every Two Months

Verify all anchor bolts are secure and torque to 85-95 ft.-lbs.

Every three to five years or as required

1. Carefully check the Equalizing Cables for signs of damage or extreme wear. See [Wire Rope Inspection and Maintenance](#) for additional information.
2. If the Lift becomes inoperative in a raised position, refer to the [Troubleshooting](#) section.

Lubrication Procedure

To Lubricate the Upper Corner Sheaves:

1. Raise the Lift Head to rest on at least the first Safety Lock.
2. Remove the Polyethylene Cover from the Lift Heads then loosen the Cable Nuts to relax the Equalizing Cables.
3. Lubricate the Upper Corner Sheave.
 - a. Remove Screw securing pin at the upper sheave.
 - b. Remove the Pin from the Sheave.
 - c. Apply Red Lithium Grease to the Pin.
 - d. Reinstall the Sheave Pin through the Sheave then insert and tighten screw.
 - e. Repeat for the remaining upper sheaves.
 - f. Tighten the Cable Nut.

See Leveling Section to readjust Lift Arms.

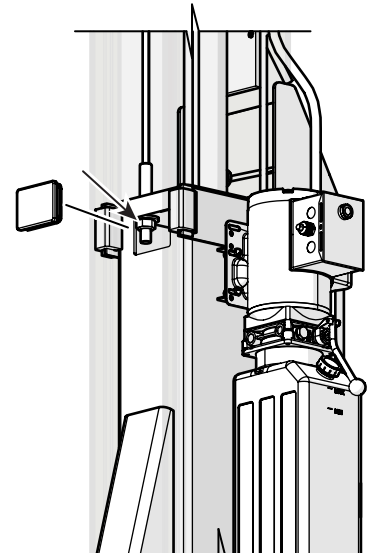

To Lubricate the Lower Sheaves:

1. Relax Equalizing Cables, as outlined above.
2. Unscrew the Sheave Pin Bolt.
3. Remove Sheave Pin.
3. Apply Red Lithium Grease to Sheave Pin.
4. Reassemble and tighten all fasteners.

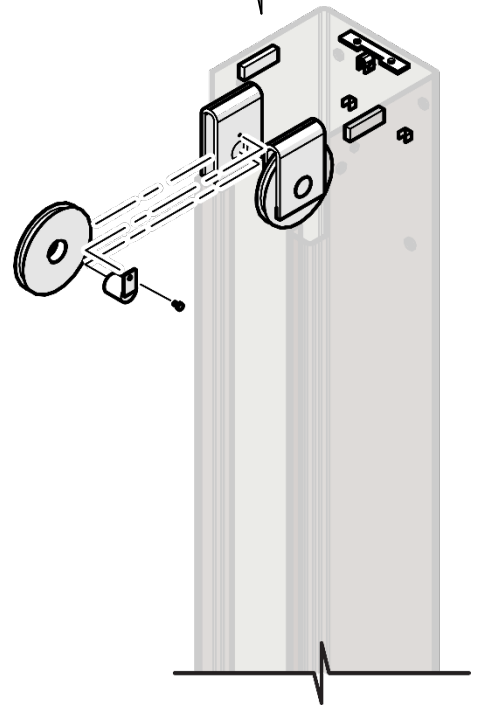
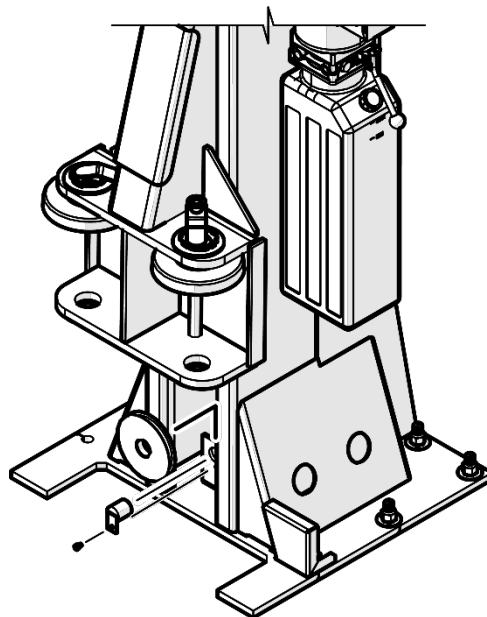

16AP and 20AP Series Wire Rope Inspection and Maintenance

The Lift's wire ropes should be inspected regularly:

- Lifting and equalizing cables should be replaced when there are visible signs of damage or extreme wear. **Do not use the Lift if it has damaged or worn cables.**
- Cables should be always maintained in a well-lubricated condition.

Wire rope is fully protected when each wire strand is lubricated both internally and externally. Excessive wear shortens the life of wire rope. Use a wire-rope lubricant that penetrates to the core of the rope and provides long-term lubrication between each individual strand, such as 90-WT gear oil or ALMASOL® Wire Rope Lubricant.

To make sure that the inner layers of the rope remain well lubricated, lubrication should be carried out at intervals not exceeding three months during operation.

- All sheaves and guide rollers in contact with the moving rope should be given regular visual checks for surface wear and lubricated to make sure they run freely. This operation should be carried out at appropriate intervals generally not exceeding three months during operation.

For all sheave axles, use standard wheel bearing grease. For all sheaves and/or guide rollers, use 90-WT gear oil or a similar heavy lubricant, applied by any method including pump/spray dispensing, brush, hand, or swabbing.

- How often should you inspect?

Lifting cables should be visually inspected at least once each day when in use, as suggested by American Petroleum Institute's Recommended Practice 54 guidelines. Any lifting cables that have met the criteria for removal must be immediately replaced.

- When should you replace lifting cables due to broken wires?

Lifting cables should be removed from service when you see six randomly distributed broken wires within any one lay length, or three broken wires in one strand within one lay length.

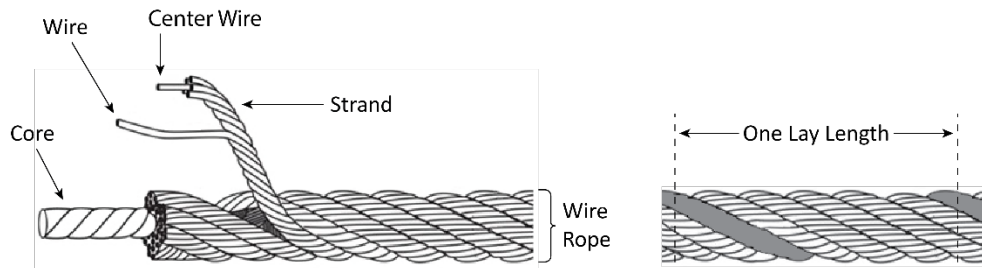



- Are there other reasons to replace your lifting cables?

Yes. Corrosion that pits the wires and/or connectors, evidence of kinking, crushing, cutting, bird-caging, or a popped core, wear that exceeds 10% of a wire's original diameter, or heat damage.

- How do you find broken wires?

- a. Relax your rope to a stationary position and move the pick-up points off the sheaves. Clean the surface of the rope with a cloth — a wire brush, if necessary — so you can see any breaks.
- b. Flex the rope to expose any broken wires hidden in the valleys between the strands.
- c. Visually check for any broken wires. One way to check for crown breaks is to run a cloth along the rope to check for possible snags.
- d. With an awl, probe between wires and strands and lift any wires that appear loose. Evidence of internal broken wires may require a more extensive rope examination.

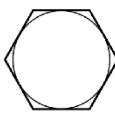
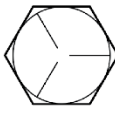
Torque Chart

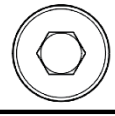
FASTENER TORQUE CHART																	
Bolt Size (SAE)	Bolt Grade (SAE)	Bolt Class (Metric)	SAE Grade 0-1-2	SAE Grade 5	SAE Grade 8	Socket Head Cap Screw SAE Grade	Tightening Torque			Tightening Torque			Tightening Torque				
							Lubricated (ft-lbs)	Zinc Plated (ft-lbs)	Plain & Dry (ft-lbs)	Lubricated (ft-lbs)	Zinc Plated (ft-lbs)	Plain & Dry (ft-lbs)	Lubricated (ft-lbs)	Zinc Plated (ft-lbs)	Plain & Dry (ft-lbs)		
																	
			4.6	8.8	10.9	Metric Class 12.9											
Bolt Size (SAE)	Bolt Size (Metric)	Bolt Class (Metric)	Zinc Plated (ft-lbs)	Plain & Dry (ft-lbs)	Lubricated (ft-lbs)	Zinc Plated (ft-lbs)	Plain & Dry (ft-lbs)	Lubricated (ft-lbs)	Zinc Plated (ft-lbs)	Plain & Dry (ft-lbs)	Lubricated (ft-lbs)	Zinc Plated (ft-lbs)	Plain & Dry (ft-lbs)	Lubricated (ft-lbs)	Zinc Plated (ft-lbs)	Plain & Dry (ft-lbs)	Lubricated (ft-lbs)
1/4-20	M6 x1.0		2.3	3.0	5.8	6.6	7.7	8.3	9.4	11.1	9.7	11.0	13.0	11.0	11.0	13.0	11.0
5/16-18	M8 x 1.25		3.8	5.0	9.7	11.0	13.0	13.9	15.8	18.5	16.3	18.4	21.7	18.4	18.4	21.7	18.4
3/8-16	M10 x 1.50		10.8	14.4	27.9	31.6	37.2	39.9	45.2	53.2	46.7	52.9	62.2	52.9	52.9	62.2	52.9
7/16-14	N/A		24.0	30.0	35.0	42	50.0	55.0	59	70.0	61.0	68	76.0	68	68	76.0	68
1/2-13	M12 x 1.75		18.9	25.2	48.7	55.1	64.9	69.6	78.9	92.8	81.4	92.2	108.5	92.2	92.2	108.5	92.2
9/16-12	M14 x 2.00		30.2	40.2	77.8	88.1	103.7	111.3	126.1	148.4	130.0	147.4	173.4	147.4	147.4	173.4	147.4
5/8-11	M16 x 2.00		47	62	121	137	161	173	196	230	202	229	269	229	229	269	229
3/4-10	M18 x 2.50		65	86	167	189	222	239	270	318	279	316	372	316	316	372	316
7/8-9	M22 x 2.50		136	182	320	365	430	460	515	600	510	575	640	575	575	640	575

WARNING! Prior to installation, inspect all accompanying manuals, parts lists and catalogs to ensure you have all the necessary parts. Identify all fasteners and their proper torque settings as illustrated on this chart. Proper torquing practices cannot be over emphasized. Torque values are provided as a convenient method of achieving correct pre-loading of highly stressed fasteners. If the fasteners are not properly plated, the fastener threads are not clean and free of deformation, or are not properly lubricated, the correct fastener pre-load will not be achieved even though the given torque value is reached. For this reason, it is critical that all fasteners be inspected for proper plating, thread form and correctly lubricated prior to torquing. Failure to verify a fastener's serviceability or to correctly lubricate the fastener prior to assembly and torquing will result in the fastener not being properly pre-loaded and subsequent failure of the fastener may occur. The torque values can only be achieved if the nut (or tapped hole) has a proof load greater than or equal to the bolt's minimum ultimate tensile strength. Clamp loads estimated as 75% of proof load for specified bolts. Torque values are listed in foot-pounds. Torque wrenches should be calibrated on an annual basis. Never use an impact driver on a torque multiplier.

P

Troubleshooting

This section describes how to troubleshoot your Lift.

NOTICE If your Lift is not functioning correctly, you must take it out of service until it is fixed.

Important: Replace worn, damaged or broken parts with original BendPak or BendPak approved parts or with parts that meet or exceed the original manufacturer specifications.

⚠ DANGER Before performing maintenance on your Lift, verify it is disconnected, locked out and tagged out from power. The Lift uses electrical energy; if your organization has Lockout/Tagout policies, implement them before performing any maintenance. If you come into contact with high voltage, you could be injured or killed.

Issue	Action to Take
Lift becomes inoperative in a raised position.	Verify there is sufficient Hydraulic Fluid in the reservoir. Verify the Lift Carriages are above and clear of the Safety Locks. Verify none of the Hydraulic Hoses are pinched or leaking. Verify the Power Unit is being supplied power. Make sure the Lift is not overloaded. Make sure the load on the Lift is balanced. Contact bendpak.com/support . or by phone at (800) 253-2363 , press option 7 then 5.
Arms move erratically or squeak when in use.	Move the Lift Arms up and down a few times to flush any residual air from the Hydraulic System.
Offside Lift Head will not lower.	See broken Safety Cable procedure below.
Lift does not stay up.	Make sure to leave the Lift engaged on its Safety Locks. Check for Hydraulic Fluid leaks.
Vehicle on Lift not level.	Make sure the Lift is engaged on Safety Locks at the same height. Verify the Safety Locks in both posts are engaged. If either condition is not met, carefully lower the Vehicle back down to the ground and raise it again.
Motor not running.	Check the connection to the facilities' power source; make sure it is plugged in and the appropriate voltage is supplied. Check the wiring diagram on Power Unit.
Hydraulic Fluid is dirty.	Replace the dirty Hydraulic Fluid with clean, approved ATF fluids, such as Dexron III, Dexron VI, Mercon V, Mercon LV, or comparable.
Lift makes odd noises.	Lubricate hinge points using white lithium grease.

Technical support and service is available from your dealer, on the Web at [bendpak.com/support](https://www.bendpak.com/support), by email at support@bendpak.com, or by phone at **(800) 253-2363**, press option 7, then 4. Online chat is also available at www.bendpak.com click the chat icon.



Broken Safety Cable Procedure

If the Safety Cable breaks, the power side Lift head will lower but the Offside Lift Head will not.

To release the Offside Safety Lock:

1. Raise the Lift Heads off the Safety Locks.
2. Have an assistant reach through the access hole with a stiff wire or pick to pull the Safety Block away from the Lift Head. See figure below.
3. Hold in the Safety Release on the power side Lift Post while holding the lower handle on the Power Unit.
4. When the Lift heads are on the ground and the Lift is in a safe condition, remove power from the Lift and replace the Safety Cable.

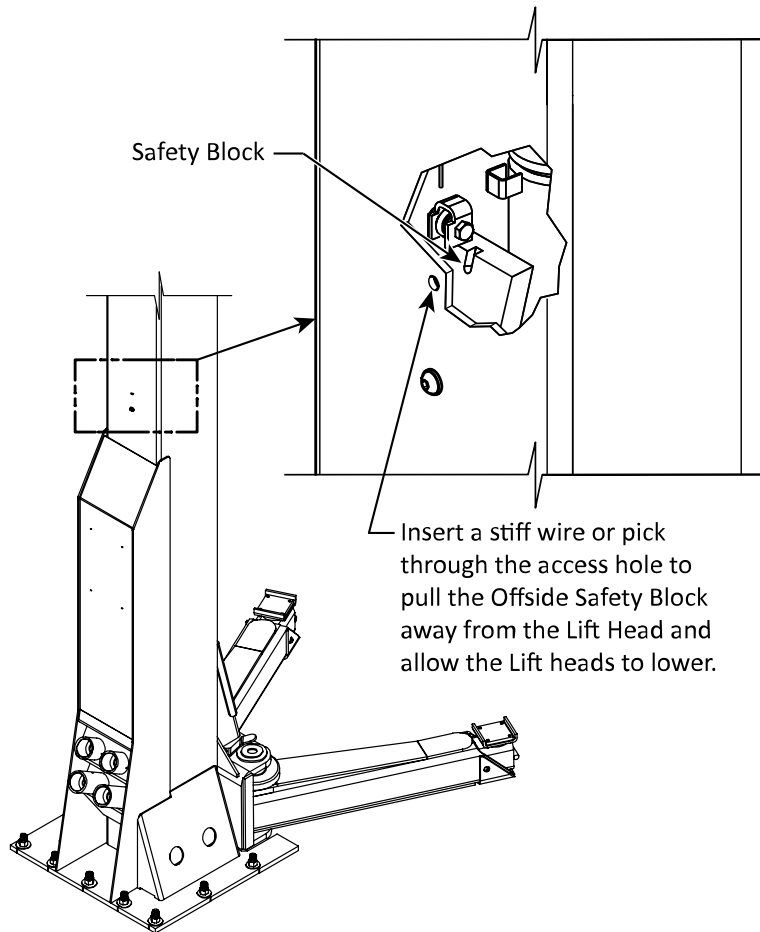

Reference only – do not scale.

To replace a previously installed or broken Safety Cable:

1. Lower the lift carriages to reveal the safety lock assemblies.
2. Loosen the cable retaining fastener on the POWER SIDE SAFETY HANDLE ASSEMBLY. This will create some slack in the cable. Refer to the figure on the right.
3. Locate the swaged metal end of the safety lock cable on the off side lift post (as shown below) and gently pull the cable assembly toward you until the complete end of the swaged metal end is exposed. Be cautious not to pull the cable all the way out.
4. With the entire swaged metal end now visible, use a cable cutter to cut off the last half-inch of the cable, including the swaged end. Avoid pulling the cable entirely out.
5. With the swaged metal end removed, the remaining end of the safety lock cable itself will serve as a fish wire and guide for routing the new replacement cable.
6. Securely tape the new cable (PLAIN END) to the old cable using strong tape. The tape should have excellent tearing and adhesive strength. Ensure the tape is tight against the cable sections, preventing any interference with the cable sheave brackets when threading the safety cable through the upright column sheave and bracket assemblies.
7. Employ the old cable as a guide to gently pull the new cable through to its destination at the POWER SIDE SAFETY HANDLE ASSEMBLY.
8. Adjust the safety cable as necessary to ensure both safety locks disengage simultaneously when pressing the POWER SIDE SAFETY HANDLE ASSEMBLY. Also, confirm that positive safety lock engagement occurs at both columns during lift operation.

Loosen the cable retaining fastener

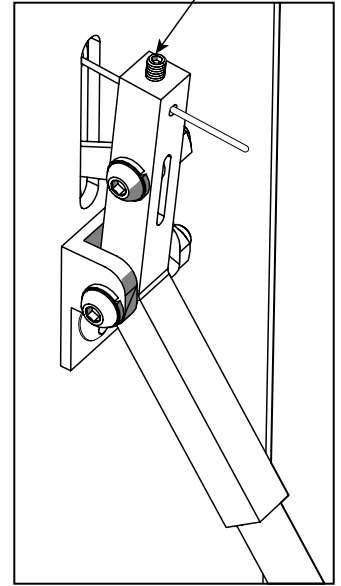

Gently pull, then cut to remove the swaged end

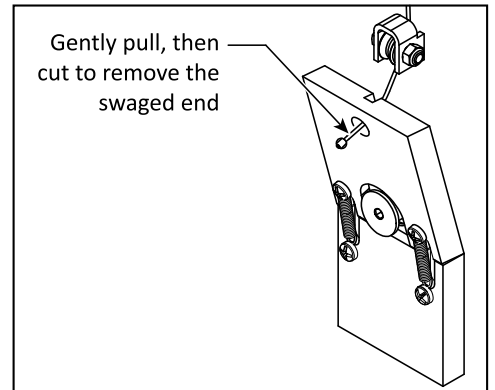

Troubleshooting Lift Arm Lock Disengagement

⚠ WARNING Avoid excessive Shim heights! A new concrete cutout and steel reinforced pour are recommended to correct out of level conditions in excess of 3°.

Some floors with excessive out of level conditions may require Shim heights that reach or exceed .5 in. (12.7 mm). When the Shim Height reaches this level, the Lift Arm Lock Pins may not function to disengage the Lift Arms when completely lowered. To correct this condition, the Arm Lock Pins include an M12 x 1.75 internal thread, approximately 12 mm deep. A mating M12 Hex Head Bolt with Lock Washers, or a backing nut (not supplied) may be used to extend the contact point of the Arm Lock Pins. Adjust the Bolt head position to disengage the Lock as required. Refer to the figure below.

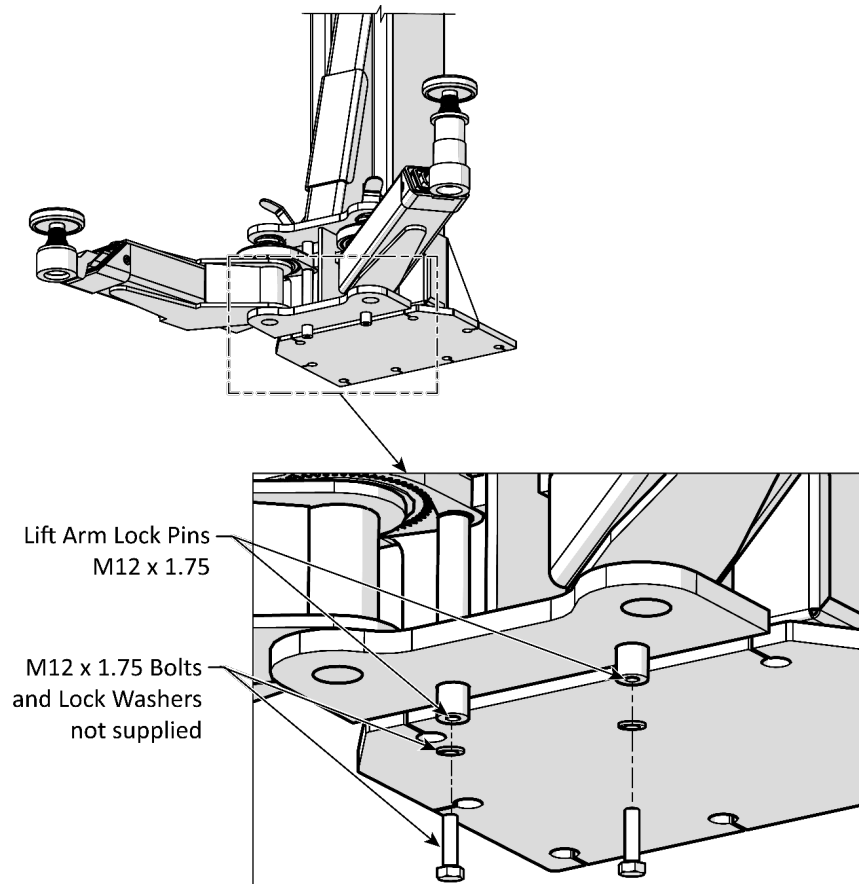

Disposing of Used Hydraulic Fluid

Used Hydraulic Fluid cannot be disposed of by dropping it into the trash or dumping into the street. Hydraulic Fluid has toxic ingredients that are harmful to the environment. Either recycle the Hydraulic Fluid or drop it off at a hazardous waste collection facility. Dirty or contaminated fluid must be treated as hazardous waste. Rags and/or granular absorbents that have soaked up Hydraulic Fluid should be treated like hazardous waste and be disposed of at a hazardous waste collection facility.

To find an appropriate facility:

- Local automotive parts stores, auto care facilities, or automobile dealerships may accept fluid for recycling or, in some cases, for disposal. Contact them for more information.
- Cities, counties, and states often support both recycling facilities and hazardous waste collection facilities. Contact them to see if and where they have these programs.

If you are unable to find an appropriate facility, the website earth911.com has resources that may be of help.

Lift Disposal - End of Service Life

Once your Lift has reached the end of its service life it must be disposed of properly. Metal recyclers will be able to advise on methods and costs to remove the Lift and will reuse the materials, diverting them from landfills. The best option is to contact a metal recycling center and discuss the size and weight of the Lift to determine if the facility can deconstruct and recover the usable components and metals.

The Hydraulic Cylinders, Hoses, Fittings, and the Power Unit itself must be disposed of in accordance with current national, state, and local regulations governing the use and disposal of hazardous materials. These components and any used Hydraulic Fluid must not be disposed of by dropping it into the trash or dumping it into the street. The Hydraulic Fluid contains toxic ingredients that are harmful to the environment.

These components and the Hydraulic Fluid are required to be recycled or must be delivered to a hazardous waste collection facility.

If you have large amounts of Hydraulic Fluid, consider contacting a commercial waste disposal company. In all cases, the best approach is to find an appropriate facility and contact them — in advance — to ask them: what kinds of fluids and materials they accept, what kind of containers it must be in, what hours they are open, their location, and any other information specific to their facility.

If you are unable to find an appropriate facility, the website earth911.com has resources that may be of help.

Wiring Diagrams

Single-Phase Overhead Limit Switch and Power Unit Wiring

⚠ DANGER All wiring **must** be performed by a licensed Electrician in accordance with all local, state, and national electrical codes. Verify that main electrical power has been disconnected from the Lift and cannot be re-energized until all procedures are complete. If your organization has Lockout/ Tagout policies, make sure to implement them after connecting the Lift to power.

IMPORTANT! The Power Unit Consumes 23 Amps at 208-230 VAC, 50/60 Hz., Single Phase, 5 HP. The electrical circuit should be protected by a 30 Amp Circuit Breaker or time-delay fuse.

To Connect the Limit Switch (Single Phase):

1. Remove and retain the three Cover Screws.
2. Remove and retain the Switch Cover.
3. For Single Phase installations, feed the 14/2 cord through the Strain Relief in the Switch Cover.
4. Strip the insulation off two of the conductors and connect to the Normally Closed Terminals. One wire to terminal 21 and the other to terminal 22.
5. Inspect to verify no stray wire strands are bridging across the terminals. If strands are bridging, correct before proceeding.
6. Replace the Switch Cover and secure with the three screws removed in step 1.

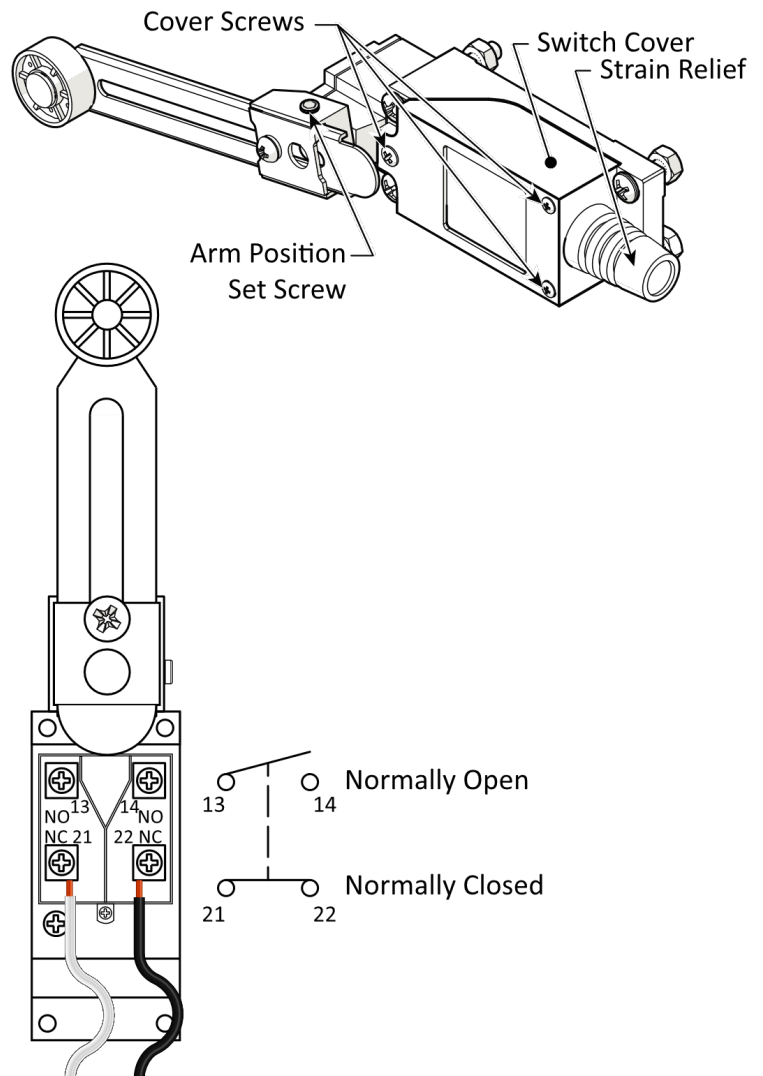

Single-Phase Power Unit Wiring

Important! The Power Disconnect and Thermal Disconnect are not supplied with this Lift. These components must be supplied and installed by a licensed Electrician in accordance with the National Electrical Code (NEC). The Thermal Disconnect while not an NEC requirement may be required by local electrical code.

Power Unit (5585685)

208-230VAC, 1 Ph., 50/60 Hz. 5 HP, 23 Amps, CSA approved

Single-Phase

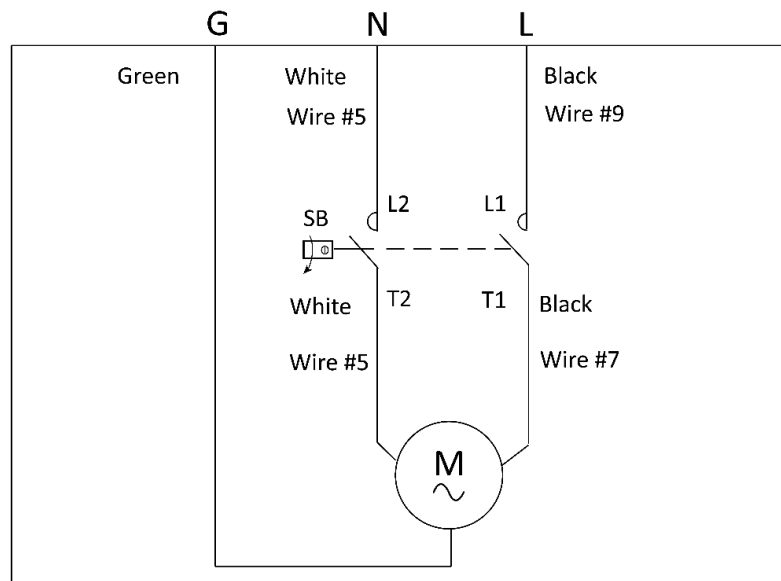
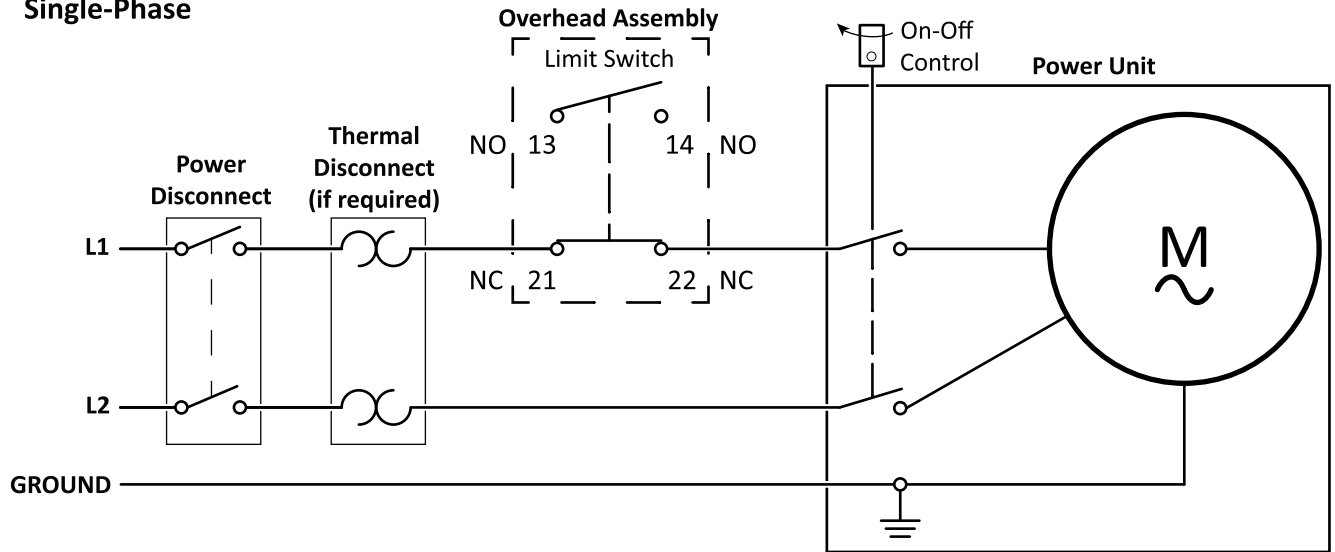

Three-Phase Limit Switches Installation

This section includes assembly and wiring information for the Three Phase Overhead Limit Switches. Requires the **AP Clear Floor 3ph Micro Switch Kit part number 5216263**.

⚠ DANGER All wiring **must** be performed by a licensed Electrician in accordance with all local and national electrical codes. Make sure that main electrical power has been disconnected from the Lift and cannot be re-energized until all procedures are complete.

To Wire the Limit Switches (Three Phase):

1. Remove and retain the three Cover Screws on both Limit Switches.
2. Remove and retain the Limit Switch Covers.
3. Strip Back the Jacket of the 14/4 Cable about 5 inches (127 mm) to expose the 4 conductors.
4. Push the black and white wires through the strain relief on one switch cover and the red and brown through the Strain Relief on the remaining cover.
5. Strip the insulation back on all four conductors about 1/2 in. (13 mm) and connect one wire to each side of the *Normally Closed Terminals* on each switch. Refer to the figure below. Inspect to verify no stray or broken wire strands are bridging across the terminals.
6. Replace the Switch Covers and secure with the three screws removed in step 1.

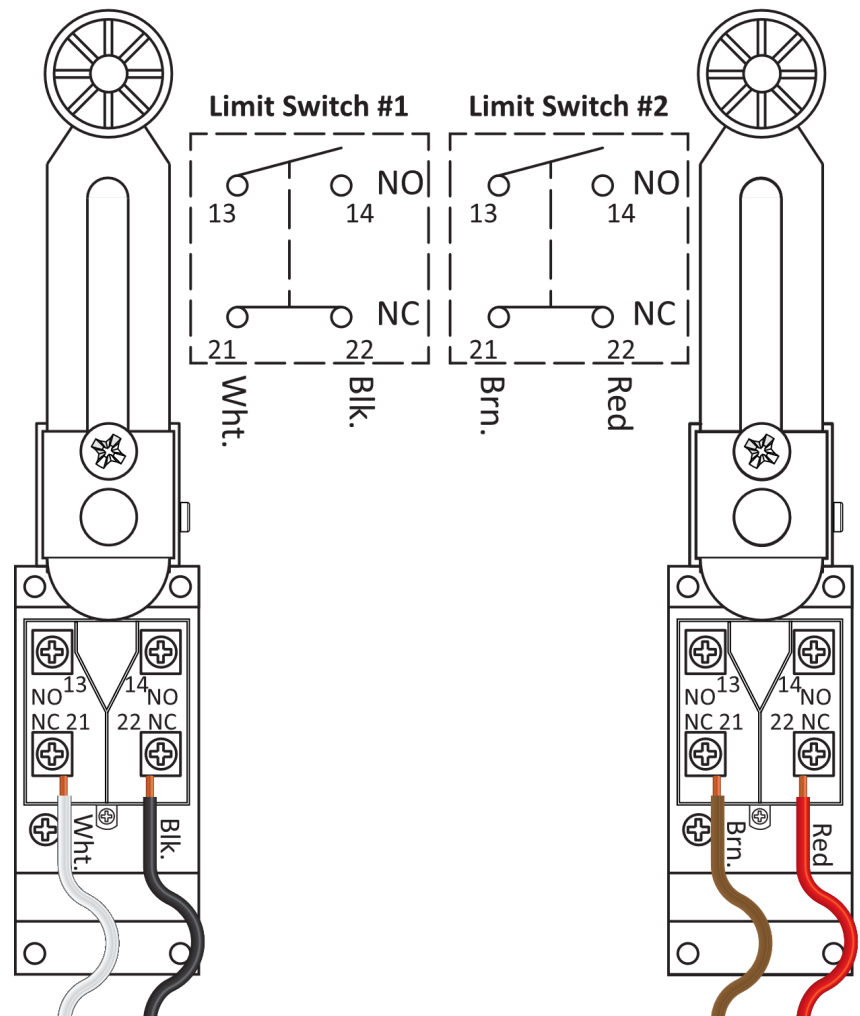

7. Secure the switches to the bracket on the Overhead assembly. Refer to the figures below Wiring removed for clarity.
8. Attach the 3-Phase Limit Switches to the Lift's Overhead Assembly using the fasteners described below.

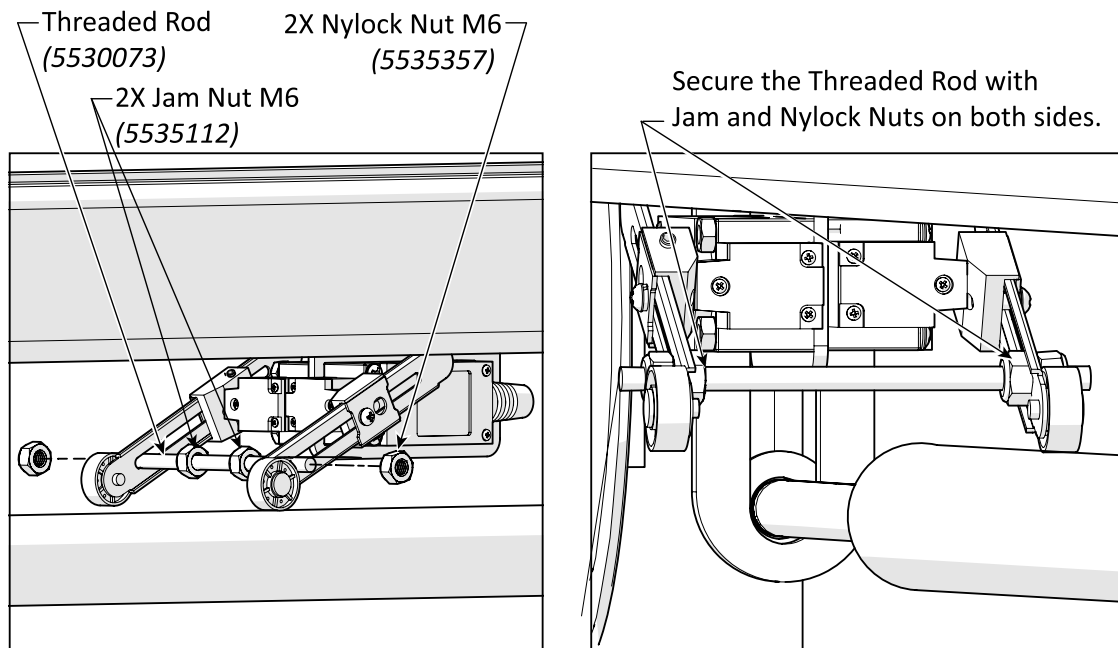
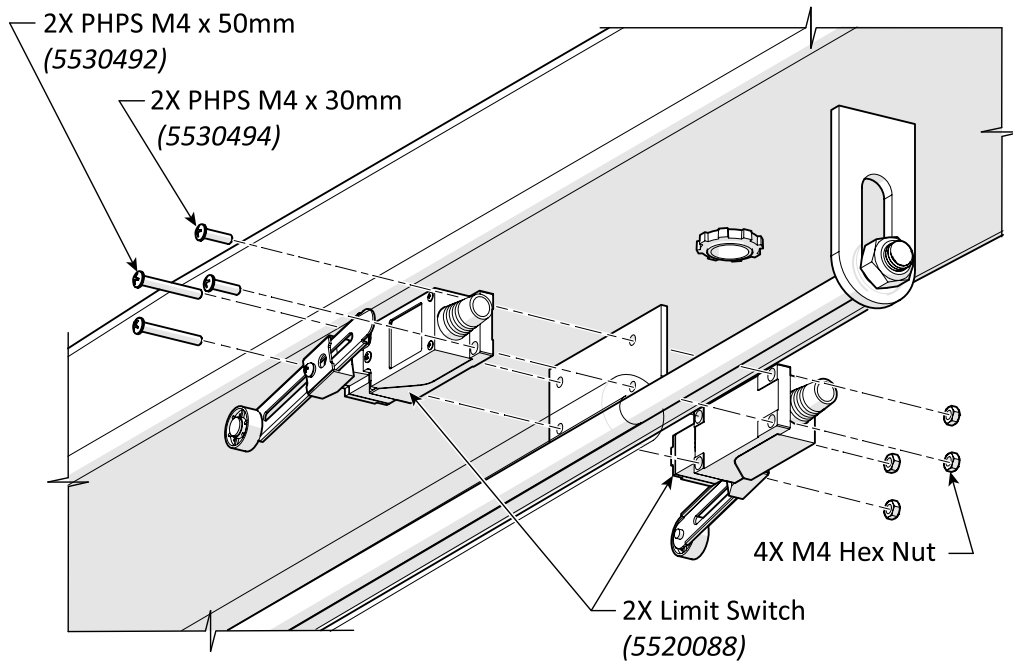

Components removed for clarity.

9. Assemble the Threaded Rod Spacer between the Actuator Arms and secure with the Jam Nuts as shown above.
10. Loosen **BOTH** Arm Rotation Set Screws and allow the Actuator Arm to rest on the Limit Switch Stop Bar. Adjust the length of the Actuator Arm, if required.

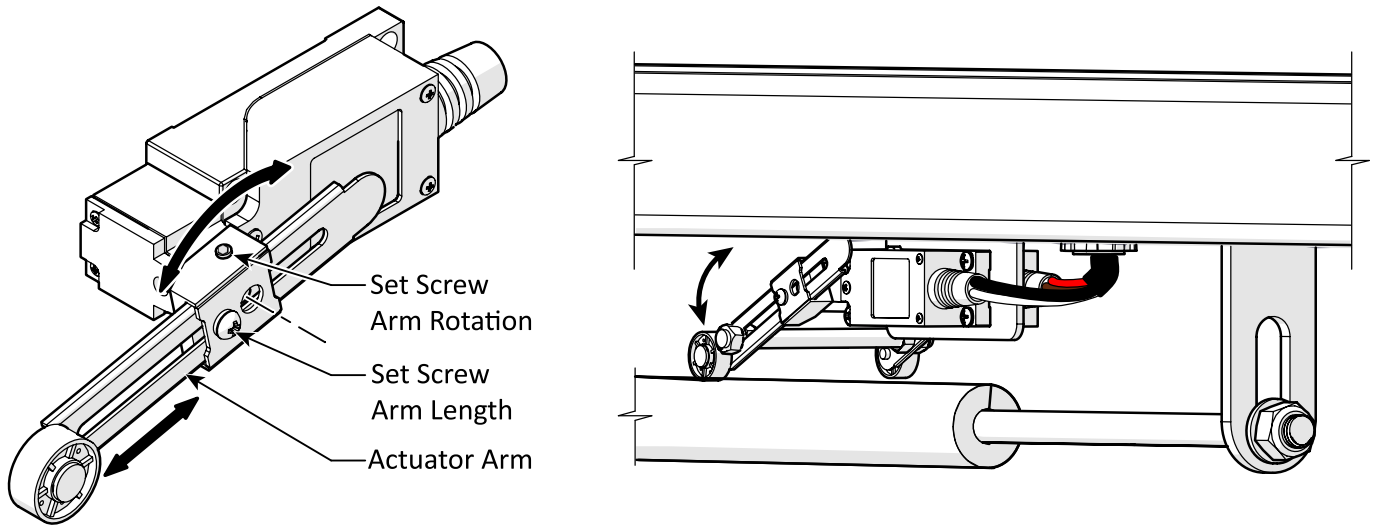

11. Tighten the Arm Rotation Set Screws on **BOTH** Limit Switches.
12. Push up on the Limit Switch Stop Bar. The Limit Switches should rise and fall with the Stop Bar.
13. Feed the 14-4 Cable up through the Cable Connector and secure using the connector's two screws.
14. Route the 14-4 Cable through the Cable Clips across the Overhead and down the Power Side Lift Post.
15. Bend the Cable Clips to secure the cable flat against the Overhead and the Lift Post.
16. Verify the Cable is held firmly in the Cable Clips and has little to no slack inside the Lift Post. Excessive slack could interfere with moving components inside the Lift Post leading to Cable damage and malfunction.
17. Feed the 14-4 Cable out through the grommets below the Safety Lock Release.

Three-Phase Power Unit Wiring

IMPORTANT! The Power Disconnect and Thermal Disconnect are not supplied with this Lift. These components must be supplied and installed by a licensed Electrician in accordance with the National Electrical Code (NEC). The Thermal Disconnect while not an NEC requirement may be required by local electrical code.

⚠ DANGER All wiring **must** be performed by a licensed Electrician in accordance with all local and national electrical codes. Make sure that main electrical power has been disconnected from the Lift and cannot be re-energized until all procedures are complete.

Three-Phase Block Diagram

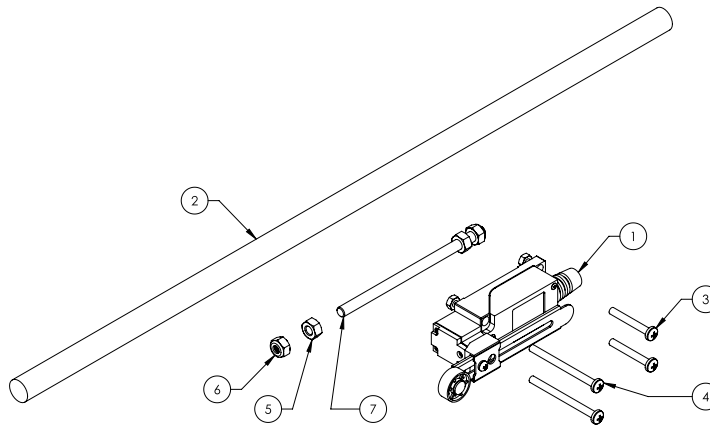
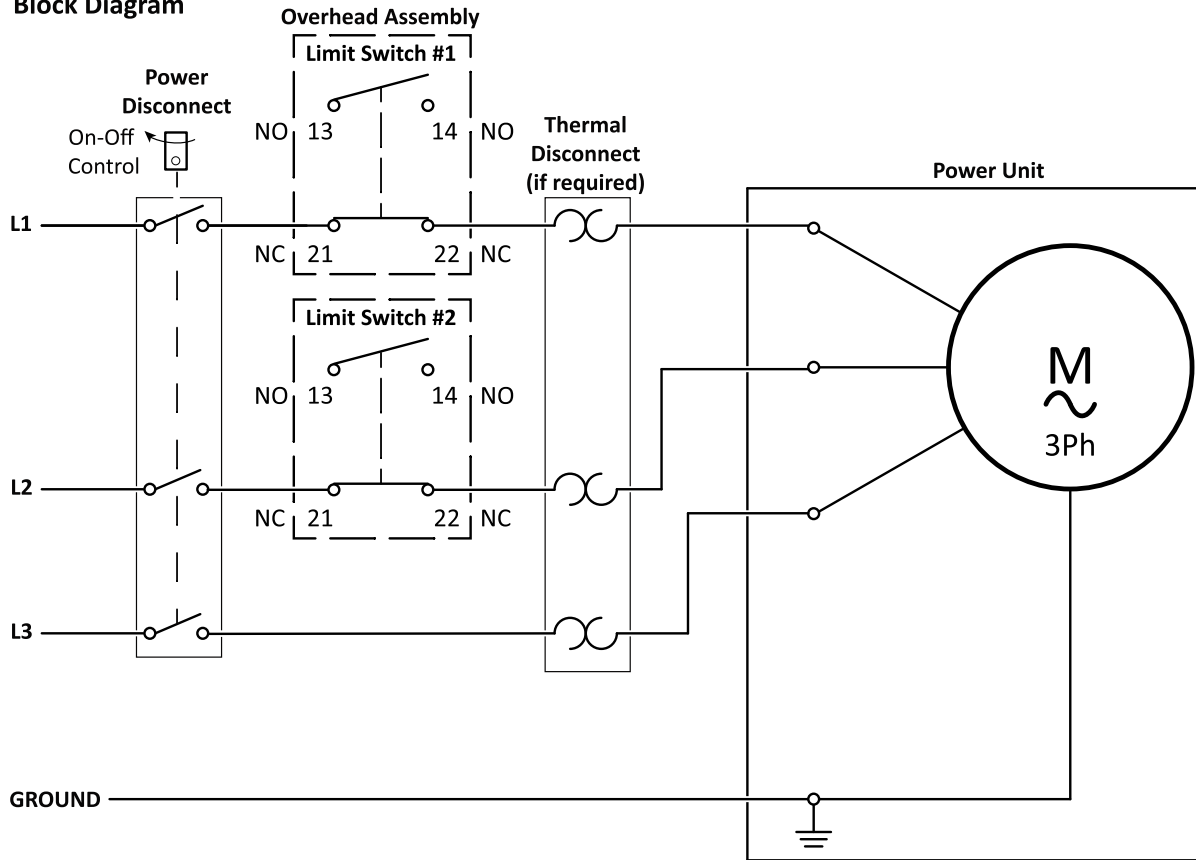

NOTE: UNLESS OTHERWISE SPECIFIED...
 1. REFER TO MODEL FOR ADDITIONAL INFORMATION
 2. SEE SHIPPING INSTRUCTIONS FOR FINAL PACKAGING

ITEM NO.	PART NUMBER	DESCRIPTION	QTY	REV
1	5520088	ROCKER LIMIT SWITCH, 25A	1	--
2	5520116	CABLE, AWG 14-4, SOOW	5000mm	--
3	5530494	PHPS M4 x 0.7 x 30 FT	2	--
4	5530492	PHPS M4 x 0.7 x 50 FT	2	--
5	5535112	NUT M6 x 1.0	2	--
6	5535357	NUT M6 x 1.0 NLT, CL10.9	2	--
7	5530073	THREADED ROD M6 x 1.0 x 110 FT, CL 4.8	1	--

DO NOT SCALE DRAWING		NAME	DATE	BendPak 3040 AGOURA RD. AGOURA HILLS, CA 91301
DRAWN	TM	03/27/2024		
CHECKED				
DIMENSIONS ARE IN MM		THIRD ANGLE PROJECTION	TITLE: AP CLEARFLOOR 3ph MICROSWITCH KIT	
WHERE USED		SEE DWG. NO.	REV	
3 PHASE LIFTS		A	5216263	A
		SCALE: 1:2	SHEET 1 OF 1	

Labels

A



16P and 20AP Series Two-Post Lifts
 16P and 20AP Series Two-Post Lifts
 16P and 20AP Series Two-Post Lifts
 16P and 20AP Series Two-Post Lifts

B

IMPORTANT	
<p>OPERATION / MAINTENANCE INSTRUCTIONS - PLEASE READ</p> <p>⚠ DANGER ⚠</p> <p>Long-wheelbase vehicles can damage lift and/or cause personal harm or injury to operators if loaded incorrectly. All vehicles MUST be positioned on lift with CENTER OF GRAVITY midway between adapters.</p> <p>Never lift any vehicle in any manner with FEWER than (4) arms. Rated capacity of each lift arm is no greater than 1/4th of the overall lifting capacity.</p> <p>USE PROPER ADAPTERS Do not attempt to lift trucks or other heavy vehicles with standard rubber contact pads. NEVER use standard rubber contact pads with heavy equipment. Contact adapter or your equipment dealer for product information.</p> <p>FRAME CRADLE ADAPTERS Rigs, not for use with 18" tires, 18" or 20" or 22" tires and other rig. Additional stability.</p> <p>WIDE FRAME CRADLE ADAPTERS Rigs, not for use with 18" tires, 18" or 20" or 22" tires and other rig. Additional stability.</p> <p>BUV & VAN ADAPTERS Recommander de l'usage, 2000 et au-dessus, 1800-1900, 1800-1900.</p> <p>STEEL LIFT PADS Show lift pads are recommended for all steel lift pads. The lifted edge of the lift pads should be carried out at intervals at 300mm during operation.</p> <p>REPLACEMENT POLYURETHANE TUP PADS NE PAS LES UTILISER EN CAS DE DÉFICIENCE. CONTACTER LE DÉTAILLANT POUR OBTENIR DES REMPLACEMENTS.</p>	<p>OPÉRATION / ENTRETIEN INSTRUCTIONS - LISEZ S'IL VOUS PLÂT</p> <p>⚠ DANGER ⚠</p> <p>Les véhicules à empattement long peuvent endommager l'élevateur et / ou causer des blessures corporelles aux opérateurs si les charges de manière incorrecte. Tous les véhicules DOIVENT être placés sur l'élevateur avec CENTRE DE GRAVITÉ à mi-distance entre les adaptateurs.</p> <p>Né jamais soulever un véhicule de quelque manière que ce soit avec moins de (4) bras. La capacité nominale de chaque bras de levage n'est pas supérieure à (1/4) du capacité de levage globale.</p> <p>UTILISEZ DES ADAPTATEURS APPROPRIÉS N'essayez pas de soulever des véhicules avec des bases de contact en caoutchouc standard. NE JAMAIS utiliser des bases de contact en caoutchouc standard avec des véhicules lourds. Contactez votre fournisseur ou votre équipementier pour plus d'informations.</p> <p>ADAPTATEURS DE CADRE DE CADRE Rigs, not for use with 18" tires, 18" or 20" or 22" tires and other rig. Additional stability.</p> <p>CADRE LARGE ADAPTATEURS DE CADRE Rigs, not for use with 18" tires, 18" or 20" or 22" tires and other rig. Additional stability.</p> <p>VUS & ADAPTATEURS VAN Recommander de l'usage, 2000 et au-dessus, 1800-1900, 1800-1900.</p> <p>TAMPONS DE LEVAGE EN ACIER Les tampons de levage en acier sont recommandés pour tous les tampons de levage. Les bords des tampons de levage en acier doivent être portés à intervalles de 300 mm.</p> <p>REPLACEMENT POLYURETHANE TUP PADS NE PAS LES UTILISER EN CAS DE DÉFICIENCE. CONTACTER LE DÉTAILLANT POUR OBTENIR DES REMPLACEMENTS.</p>
CAUTION MISE EN GARDE	
WARNING ATTENTION	
<p>FRAMES CRADLE ADAPTERS Rigs, not for use with 18" tires, 18" or 20" or 22" tires and other rig. Additional stability.</p> <p>WIDE FRAME CRADLE ADAPTERS Rigs, not for use with 18" tires, 18" or 20" or 22" tires and other rig. Additional stability.</p> <p>BUV & VAN ADAPTERS Recommander de l'usage, 2000 et au-dessus, 1800-1900, 1800-1900.</p> <p>STEEL LIFT PADS Show lift pads are recommended for all steel lift pads. The lifted edge of the lift pads should be carried out at intervals at 300mm during operation.</p> <p>REPLACEMENT POLYURETHANE TUP PADS NE PAS LES UTILISER EN CAS DE DÉFICIENCE. CONTACTER LE DÉTAILLANT POUR OBTENIR DES REMPLACEMENTS.</p>	
<p>TO PLACE ORDER Visit www.bendpak.com or call 1-800-373-9778</p> <p>POUR COMMANDER Visitez www.bendpak.com ou composez 1-800-373-9778</p> <p>Monday - Friday 9 a.m. - 4:30 p.m. PT</p> <p>Unit - Vendredi 9h - 16h30 PT</p>	

C

BP BendPak SANTA PAULA, CA USA
 www.bendpak.com

LIFT TYPE: SURFACE MOUNT CAP: MEDIUM DTY: MP3, BPX SEE DATA PLATE FOR PRODUCT DETAILS
 POWER: ELECTRIC/HYDRAULIC INSTALLATION: SEE OWNERS GUIDE OR CONTACT FACTORY

SAFETY INSTRUCTIONS: ATTACHMENTS, ACCESSORIES OR CONFIGURATION MODIFYING COMPONENTS THAT ARE LOCATED IN THE LOAD PATH, AFFECT OPERATION OF THE LIFT. AFFECT THE LIFT'S ELECTRICAL, SEISMIC AND/OR OTHER REQUIREMENTS SPECIFIED BY ANY OTHER AGENCY. READ AND UNDERSTAND THE UNIFORM RULES CODE (URC) AND/OR INTERNATIONAL RULES CODE (IRC).

THE MANUFACTURER, BENDPAK, DISCLAIMS LIABILITY FOR INJURY OR DAMAGE TO THE LIFT OR TO THE LIFTED LOADS OR TO THE OPERATOR OR BYSTANDERS. BENDPAK IS NOT RESPONSIBLE FOR THE LIFT'S OPERATION OR FOR THE LIFT'S PERFORMANCE. BENDPAK SHALL BE HELD HARMLESS FROM ALL SUCH CLAIMS.

ENGINEERED BY BENDPAK INC. USA MADE IN CHINA

16AP PN 5905922 20AP PN 5905934

D

⚠ DANGER ⚠

THE MAXIMUM LIFTING CAPACITY FOR THIS LIFT IS DESCRIBED BELOW

<p>Maximum Lifting Capacity XX,XXX lbs. / X,XXX kg</p>
<p>Max. Lifting Cap. / Front of Lift Center X,XXX lbs. / X,XXX kg</p>
<p>Max. Lifting Cap. / Rear of Lift Center X,XXX lbs. / X,XXX kg</p>

Exceeding the weight capacity of this lift can damage lift and/or property and may cause personal harm, injury or death to operators and/or bystanders. All vehicles MUST be positioned on lift with **CENTER OF GRAVITY** midway between adapters and/or centered on runways. Damage to lift due to overloading or misuse IS NOT covered under warranty.

LA CAPACITÉ DE LEVAGE MAXIMUM POUR CE LEVAGE EST DÉCRIT CI-DESSOUS

<p>Capacité de Levage Maximale XX,XXX lbs. / X,XXX kg</p>
<p>Max. Capacité de Levage. / Avant du centre de relèvement X,XXX lbs. / X,XXX kg</p>
<p>Max. Capacité de Levage. / Arrière du centre de levage X,XXX lbs. / X,XXX kg</p>

Le dépassement de la capacité de poids de cet élévateur peut endommager l'ascenseur et / ou les biens et peut causer des dommages corporels, des blessures voire la mort aux opérateurs et / ou aux passants. Tous les véhicules DOIVENT être placés sur l'élevateur avec le **CENTRE DE GRAVITÉ** à mi-chemin entre les adaptateurs et / ou au centre des pistes. Les dommages à l'ascenseur dus à la surcharge ou une mauvaise utilisation N'EST PAS couverte par la garantie.

16AP PN 5905921 20AP PN 5905923

E

⚠ ATTENTION ⚠

MAXIMUM LIFTING CAPACITY CAPACITÉ DE LEVAGE MAXIMUM

Lbs. Kg.

F

On following page

G

PLEASE READ

Internal packing oil may cause the cylinders to bleed oil during start up. This is normal. To extend cylinder and seal life, raise the lift to full height at least once every day.

F

NOTICE
Read operating and safety manuals before using lift.
NOTICE
Proper maintenance and inspection is necessary for safe operation.
NOTICE
Do not operate a damaged lift.

CAUTION	CAUTION
Lift to be used by trained operator only.	Authorized personnel only in lift area.
CAUTION	CAUTION
Use vehicle manufacturer's lift points.	Always use safety stands when removing or installing heavy components.
CAUTION	CAUTION
Use height extenders when necessary to ensure good contact.	Auxiliary adapters may reduce load capacity.

WARNING	WARNING
Clear area if vehicle is in danger of falling.	Position vehicle with center of gravity midway between adapters.
WARNING	WARNING
Remain clear of lift when raising or lowering vehicle.	Avoid excessive rocking of vehicle while on lift.
WARNING	WARNING
Do not override self-closing lift controls.	Keep feet clear of lift while lowering.

J

TO RAISE LIFT:

1. Press and hold **UP** button.
2. When lift is just **PAST** desired height, release **UP** button.
3. Hold down Lowering Handle. **DO NOT** hold down Safety Lock Release Handle. Lift engages on safety locks.
4. Release Lowering Handle.

TO LOWER LIFT:

1. Press and hold **UP** button for two to three seconds, moving lift off safety locks.
2. Hold down Safety Lock Release Handle **and** Lowering Handle.
3. When lift is fully lowered, release both handles.

PN 5905414

PN 5905414

H

NOTICE	<p>If attachments, accessories, or configuration modifying components used on this lift are located in the load path and affect operation of the lift, affect the lift electrical listing, or affect intended vehicle accommodation; and if they are not certified for use on this lift, then the certification of this lift shall become null and void. Contact the participant for information pertaining to certified attachments, accessories, or configuration modifying components.</p> <p>www.autolift.org ©2011 by ALI, Inc. ALI / WLSIA01</p>
---------------	--

PN 5905377

K

CALIFORNIA PROPOSITION 65

WARNING

WARNING! This product can expose you to chemicals including styrene and vinyl chloride which are on the list of over 900 chemicals identified by the State of California to cause cancer, birth defects or reproductive harm. ALWAYS use this product in accordance with the manufacturer's instructions. For more information, go to www.p65warnings.ca.gov.

PN 5905775

PN 5905775

L



PN 5906044

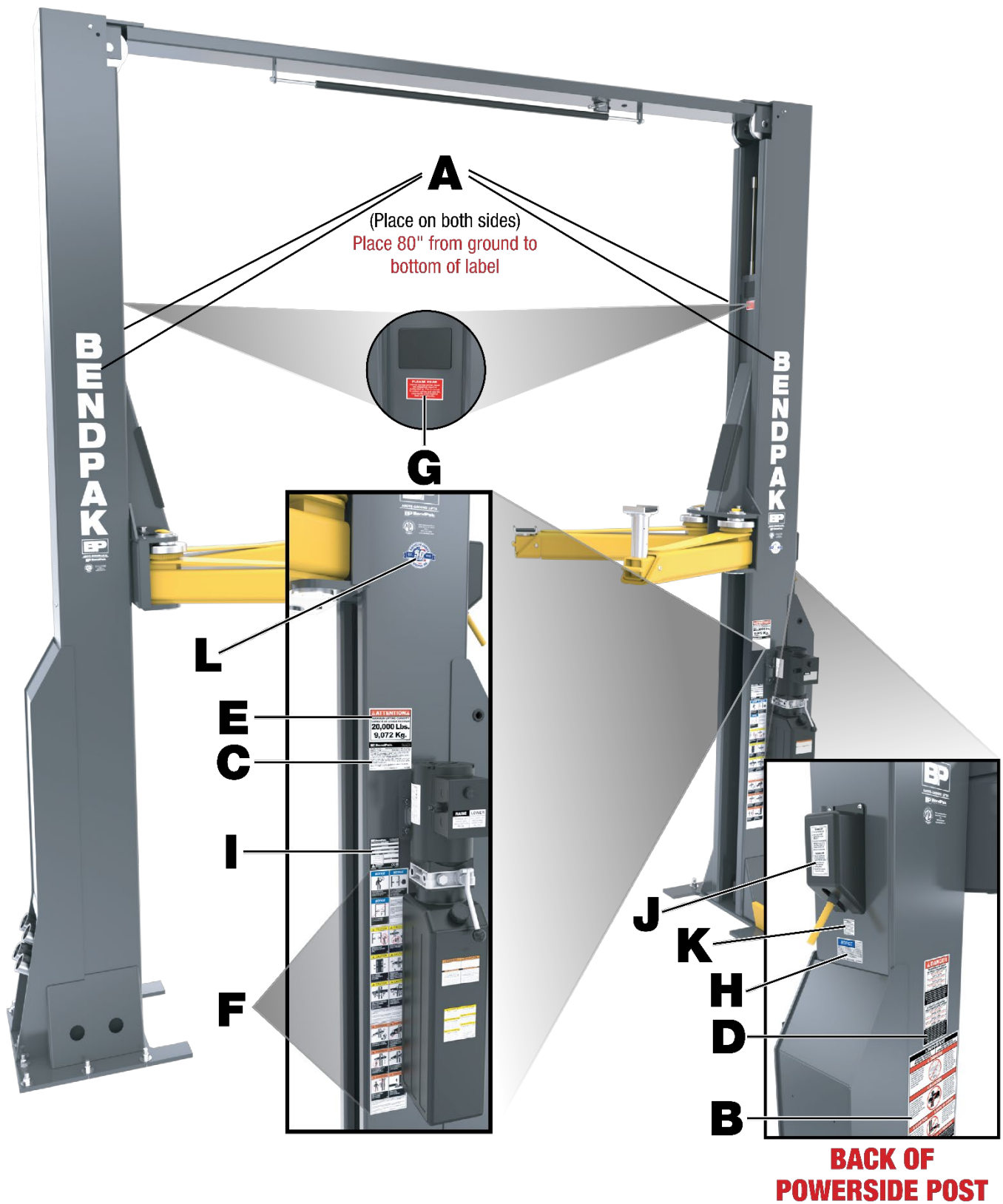

Parts Drawings

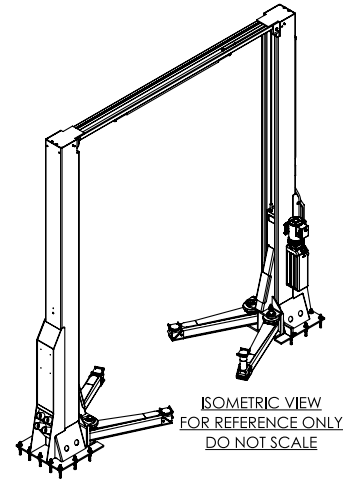
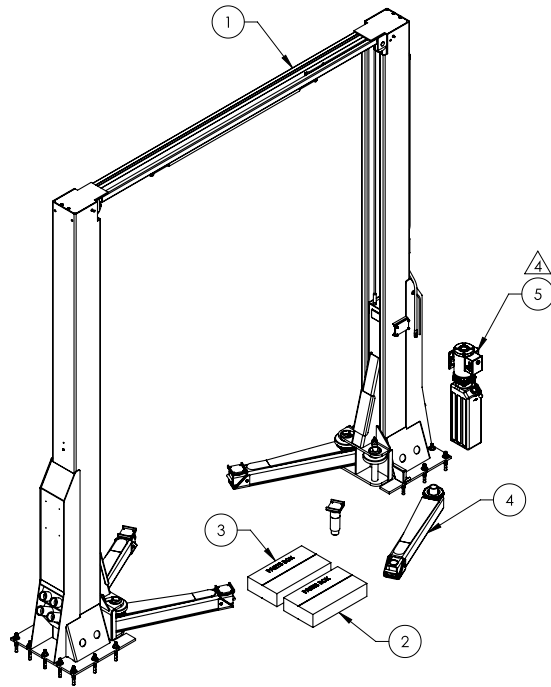

- NOTE: UNLESS OTHERWISE SPECIFIED**
1. REFER TO MODEL FOR ADDITIONAL INFORMATION
 2. SEE COLORS & GRAPHICS FOR LABEL PLACEMENT
 3. SEE SHIPPING INSTRUCTIONS FOR FINAL PACKAGING
 4. POWER UNIT REFERENCE ON PURCHASE ORDER

ITEM NO.	PART NUMBER	DESCRIPTION	QTY.	REV
1	5245290	16AP LIFT SUPERSTRUCTURE	1	C
2	5250392	16AP PARTS BOX #1	1	C
3	5250396	16/20AP PARTS BOX #2	1	A
4	5216251	16AP ARM ASSEMBLY	4	A
5	REF	POWER UNIT	1	--

DO NOT SCALE DRAWING

DRAWN: NAME: DATE: **BendPak**
 RK 02/10/2023
 1645 LEMONWOOD DR.
 SANTA PAULA, CA 93060

CHECKED: **BendPak**

THIRD ANGLE PROJECTION

ITEM NO. 16AP LIFT SUPERSTRUCTURE

DESCRIPTION 16AP PARTS BOX #1

DESCRIPTION 16/20AP PARTS BOX #2

DESCRIPTION 16AP ARM ASSEMBLY

DESCRIPTION POWER UNIT

SCALE: 1:35

SHEET 1 OF 3

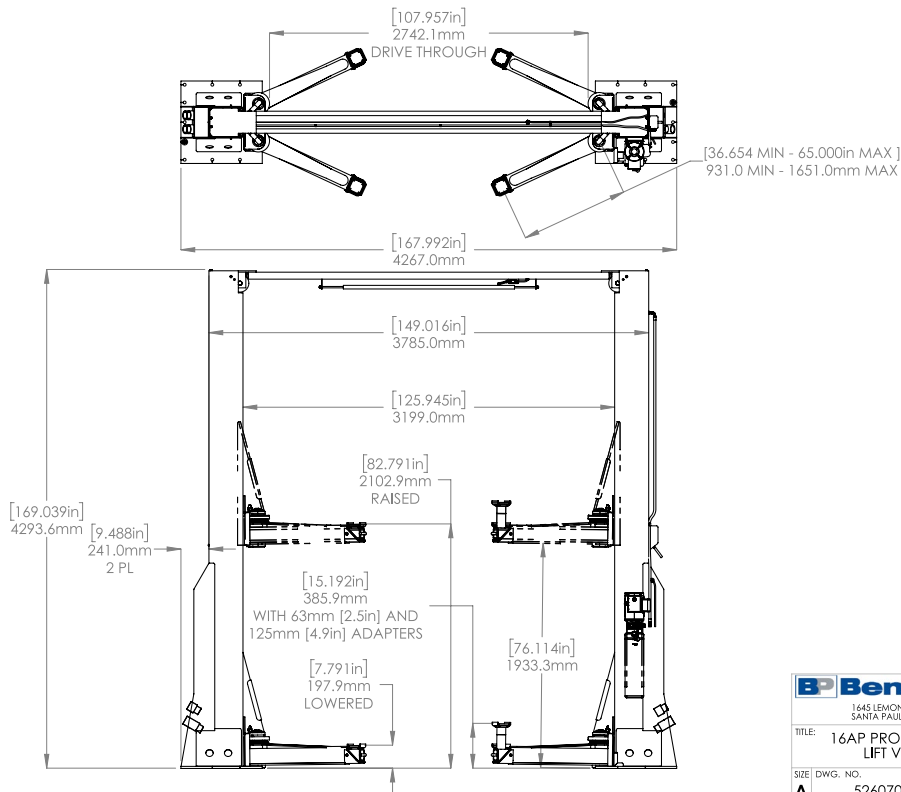

BendPak

1645 LEMONWOOD DR.
 SANTA PAULA, CA 93060

TITLE: 16AP LIFT SUPERSTRUCTURE

DESCRIPTION 16AP PARTS BOX #1

DESCRIPTION 16/20AP PARTS BOX #2

DESCRIPTION 16AP ARM ASSEMBLY

DESCRIPTION POWER UNIT

SCALE: 1:36

SHEET 2 OF 3

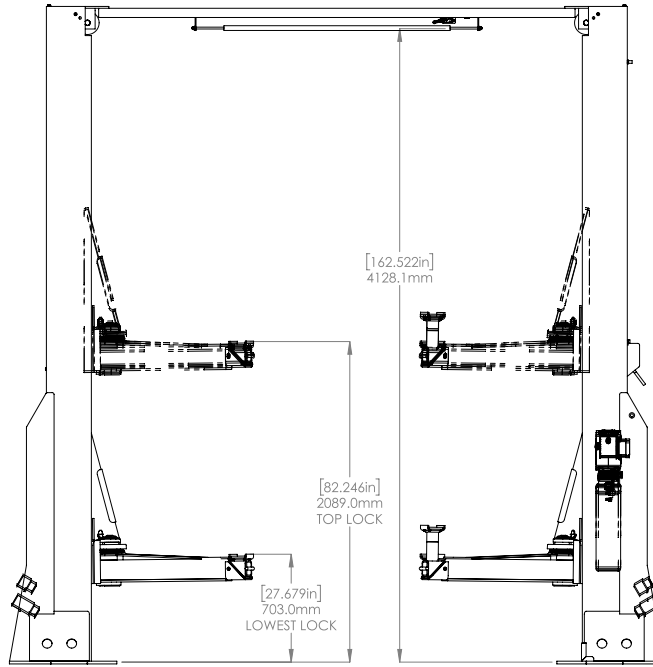

1. SAFETY LOCK POSITIONS: 15
2. SPACED EVERY: 99.0mm / 3.898"

BendPak
 1645 LEMONWOOD DR.
 SANTA PAULA, CA 95080

TITLE: 16AP PRODUCTION LIFT VER A

SIZE	DWG. NO.	REV
A	5260709	C

SCALE: 1:25 SHEET 3 OF 3

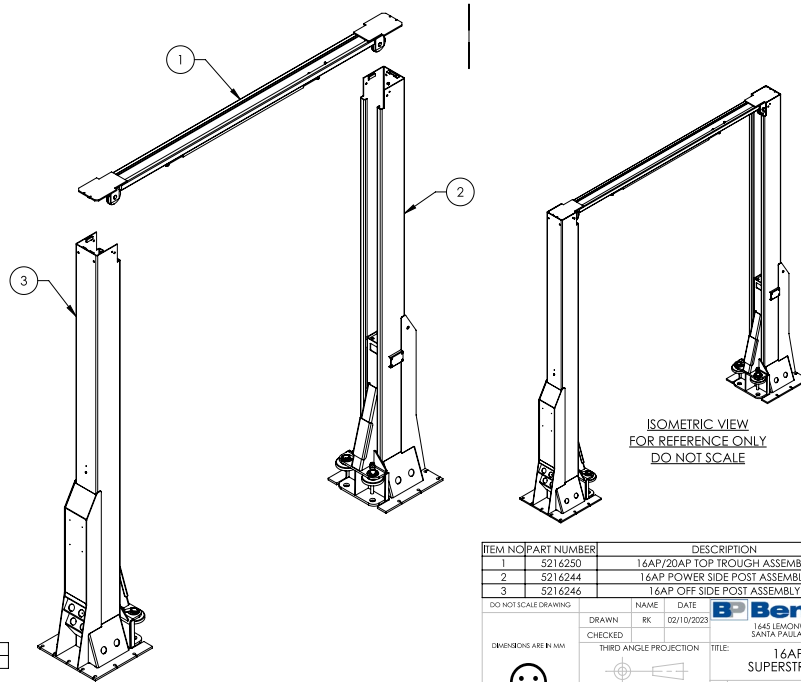

WHERE USED
16AP SERIES

NOTE: UNLESS OTHERWISE SPECIFIED
 1. REFER TO MODEL FOR ADDITIONAL INFORMATION
 2. SEE SHIPPING INSTRUCTIONS FOR FINAL PACKAGING

ITEM NO	PART NUMBER	DESCRIPTION	QTY	REV
1	5216250	16AP/20AP TOP TROUGH ASSEMBLY	1	A
2	5216244	16AP POWER SIDE POST ASSEMBLY	1	C
3	5216246	16AP OFF SIDE POST ASSEMBLY	1	B

DO NOT SCALE DRAWING

DRAWN	RK	DATE	02/10/2023
CHECKED			

DEVISIONS ARE IN MM

THIRD ANGLE PROJECTION

BendPak
 1645 LEMONWOOD DR.
 SANTA PAULA, CA 95080

TITLE: 16AP LIFT SUPERSTRUCTURE

SIZE	DWG. NO.	REV
A	5245290	C

SCALE: 1:32 SHEET 1 OF 1

PROPRIETARY AND CONFIDENTIAL
 THE INFORMATION CONTAINED HEREIN IS THE PROPERTY OF BENDPAK INC. AND IS TO BE USED ONLY FOR THE PURPOSES SPECIFIED HEREIN. WITHOUT THE WRITTEN PERMISSION OF BENDPAK INC. IT IS NOT TO BE REPRODUCED OR TRANSMITTED IN ANY FORM OR BY ANY MEANS, ELECTRONIC OR MECHANICAL, INCLUDING PHOTOCOPYING, RECORDING, OR BY ANY INFORMATION STORAGE AND RETRIEVAL SYSTEM.

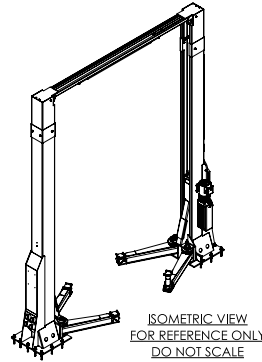
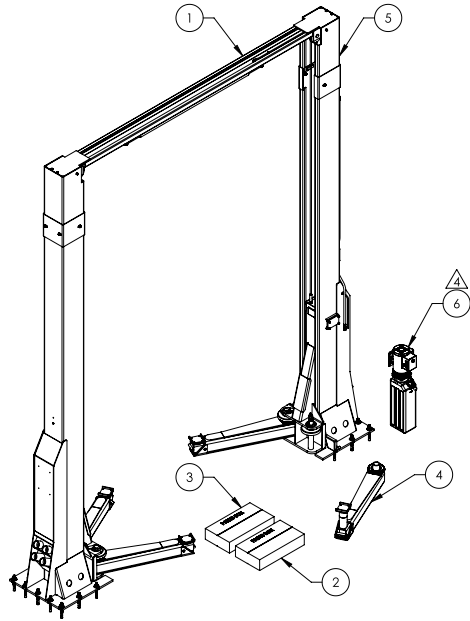

ITEM NO	PART NUMBER	DESCRIPTION	QTY	REV
1	5245290	16AP LIFT SUPERSTRUCTURE	1	C
2	5250394	16AP-192 PARTS BOX #1	1	C
3	5250396	16/20AP PARTS BOX #2	1	A
4	5216251	16AP ARM ASSEMBLY	4	A
5	5216204	12APX/16/20AP-192 POST EXTENSION ASSEMBLY	2	C
6	REF	POWER UNIT	1	--

DO NOT SCALE DRAWING

DRAWN	NAME	DATE
RK		02/10/2023

CHECKED

THIRD ANGLE PROJECTION

SMILEY FACE

1645 LEMONWOOD DR.
SANTA PAULA, CA 93060

TITLE: 16AP-192 PRODUCTION LIFT VER A

SIZE	DWG. NO.	REV
A	5260711	C

SCALE: 1:35 SHEET 1 OF 3

PROPERTY AND CONFIDENTIAL: THE DESIGN OF BENDPAK INC. IS THE PROPERTY OF BENDPAK INC. AND IS NOT TO BE REPRODUCED OR TRANSMITTED IN ANY FORM OR BY ANY MEANS WITHOUT THE WRITTEN PERMISSION OF BENDPAK INC. © 2023

NOTE: UNLESS OTHERWISE SPECIFIED

1. REFER TO MODEL FOR ADDITIONAL INFORMATION
2. SEE COLORS & GRAPHICS FOR LABEL PLACEMENT
3. SEE SHIPPING INSTRUCTIONS FOR FINAL PACKAGING
4. POWER UNIT REFERENCE ON PURCHASE ORDER

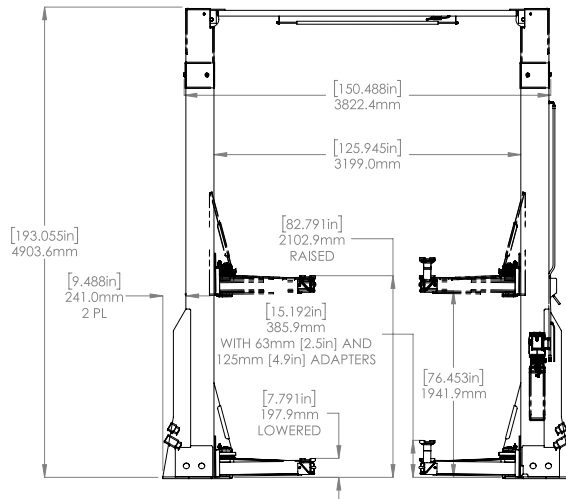
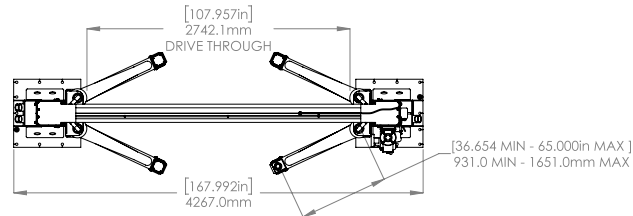

BendPak		
1645 LEMONWOOD DR. SANTA PAULA, CA 93060		
TITLE: 16AP-192 PRODUCTION LIFT VER A		
SIZE	DWG. NO.	REV
A	5260711	C
SCALE: 1:40 SHEET 2 OF 3		

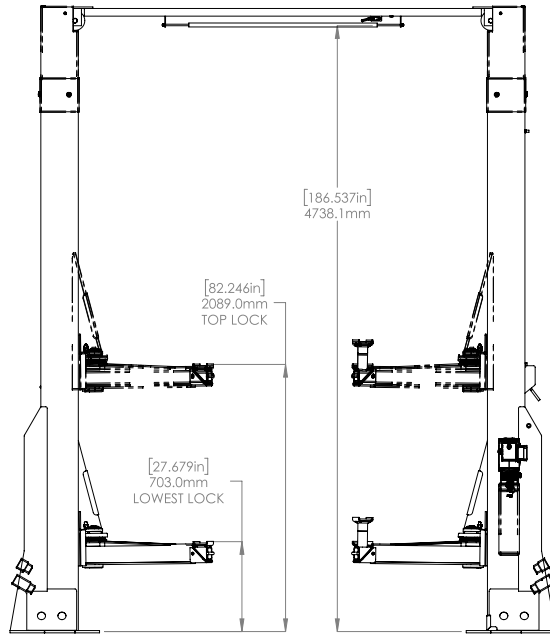

1. SAFETY LOCK POSITIONS: 15
2. SPACED EVERY: 99.0mm / 3.898"

BendPak
 1645 LEMONWOOD DR.
 SANTA PAULA, CA 93020

TITLE: 16AP-192 PRODUCTION LIFT VER A

SIZE	DWG. NO.	REV
A	5260711	C

SCALE: 1:30 SHEET 3 OF 3

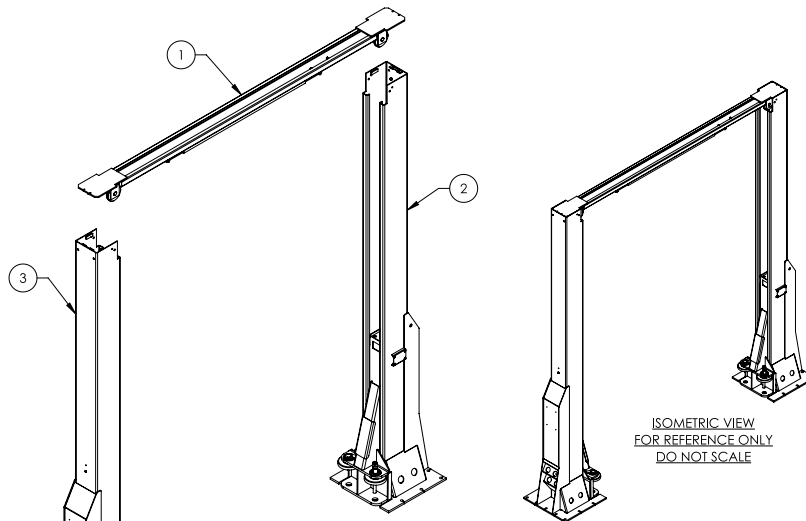

WHERE USED
16AP SERIES

- NOTE: UNLESS OTHERWISE SPECIFIED...**
1. REFER TO MODEL FOR ADDITIONAL INFORMATION
 2. SEE SHIPPING INSTRUCTIONS FOR FINAL PACKAGING

NEXT ASSEMBLY
5260709
5260711

ITEM NO	PART NUMBER	DESCRIPTION	QTY	REV
1	5216250	16AP/20AP TOP TROUGH ASSEMBLY	1	A
2	5216244	16AP POWER SIDE POST ASSEMBLY	1	C
3	5216246	16AP OFF SIDE POST ASSEMBLY	1	B

DO NOT SCALE DRAWING

DRAWN	NAME	DATE
RK		02/10/2023

CHECKED

THIRD ANGLE PROJECTION

PROPERTY AND CONFIDENTIALITY NOTICE: THE INFORMATION CONTAINED IN THIS DRAWING IS THE PROPERTY OF BENDPAK, INC. IT IS TO BE USED ONLY FOR THE PROJECT AND FOR THE SPECIFIC PART OR PARTS IDENTIFIED HEREIN. REPRODUCTION OF THIS DRAWING WITHOUT THE WRITTEN PERMISSION OF BENDPAK, INC. IS PROHIBITED.

SIZE	DWG. NO.	REV
A	5245290	C

SCALE: 1:32 SHEET 1 OF 1

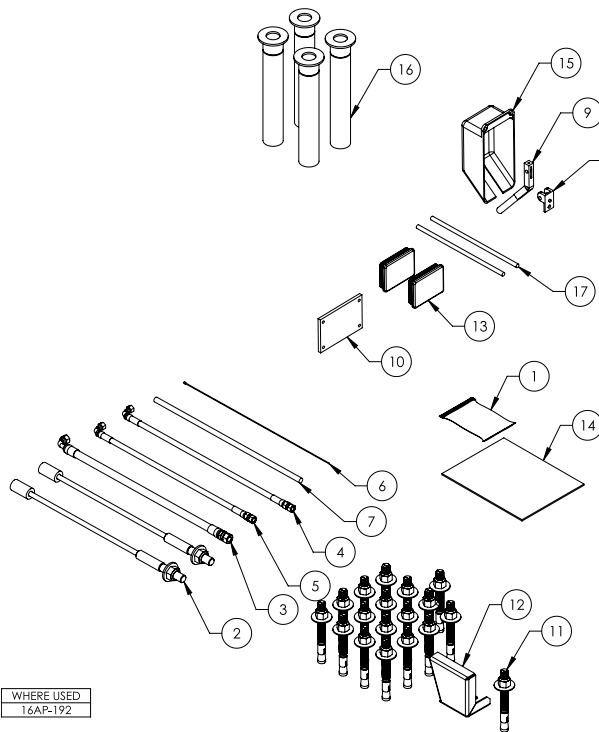

WHERE USED
16AP-192

- NOTE: UNLESS OTHERWISE SPECIFIED**
1. REFER TO MODEL FOR ADDITIONAL INFORMATION
 2. INSERT PARTS BAG INTO PARTS BOX FOR SHIPMENT
 3. HOSES AND CABLES SHOWN REPRESENTATIONAL FORM

NEXT ASSEMBLY
5260711

ITEM NO	PART NUMBER	DESCRIPTION	QTY	REV
1	5174137	16AP/20AP PARTS BAG	1	C
2	5595617	CABLE ASSEMBLY Ø12 x 11849mm ST	2	D
3	5570290	HYDRAULIC HOSE ASSEMBLY Ø10 x 2790mm SB	1	B
4	5570238	HYDRAULIC HOSE ASSEMBLY Ø6.4 x 3870mm SB	1	A
5	5570303	HYDRAULIC HOSE ASSEMBLY Ø6.35 x 9195mm SB	1	A
6	5595761	SAFETY CABLE Ø1.8 x 10070mm	1	B
7	5520032	CABLE, AWG 14-2, SOOW	4772mm	-
8	5700404	AP SAFETY PIVOT HOLDER	1	C
9	5761017	AP SAFETY HANDLE	1	E
10	5715003	POWER UNIT VIBRATION DAMPENER	1	B
11	5530308	AB 3/4" x 7"	18	-
12	5701946	16AP/20AP FOOT GUARD	1	A
13	5715196	POLYETHYLENE COVER BLOCK 105 x 80	2	D
14	5900377	16AP/20AP INSTALLATION MANUAL	1	-
15	5716072	AP POWER SIDE PLASTIC SAFETY COVER	1	A
16	5602006	16AP ARM LOCK PIN WELDMENT, Ø50	4	A
17	5746166	DOUBLE THREADED ROD M10 x 1.5 x 295	2	B

DO NOT SCALE DRAWING

DRAWN: CA, DATE: 04/25/2023

CHECKED: [Signature]

THIRD ANGLE PROJECTION

SMILEY FACE

PROPRIETARY AND CONFIDENTIAL
THE INFORMATION CONTAINED HEREIN IS THE PROPERTY OF BENDPAK INC. AND IS TO BE USED ONLY FOR THE PARTS LISTED HEREIN. REPRODUCTION OR TRANSMISSION OF THIS INFORMATION IN ANY FORM OR BY ANY MEANS WITHOUT THE WRITTEN PERMISSION OF BENDPAK INC. IS PROHIBITED.

1645 LEMONWOOD DR.
SANTA PAULA, CA 93060

TITLE: 16AP-192 PARTS BOX #1

SIZE: A, DWG. NO.: 5250394, REV: C

SCALE: 1:10, SHEET 1 OF 1

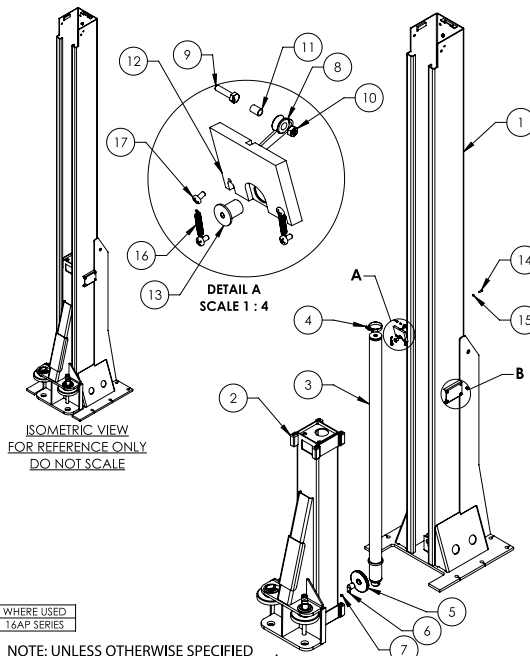

ISOMETRIC VIEW
FOR REFERENCE ONLY
DO NOT SCALE

WHERE USED
16AP SERIES

- NOTE: UNLESS OTHERWISE SPECIFIED**
1. REFER TO MODEL FOR ADDITIONAL INFORMATION
 2. SEE SHIPPING INSTRUCTIONS FOR FINAL PACKAGING ASSEMBLY ITEMS AS SHOWN
 3. INSTALL RIVET NUTS INTO POST BRACKET AS SHOWN

NEXT ASSEMBLY
5245290

ITEM NO	PART NUMBER	DESCRIPTION	QTY	REV
1	5601995	16AP/20AP POWER SIDE POST WELDMENT	1	B
2	5216248	16AP LIFT HEAD ASSEMBLY	1	B
3	5502061	CYLINDER ASSEMBLY Ø2.75 x .75	1	B
4	5701947	CYLINDER CLAMP ASSEMBLY 80-85	1	-
5	5575113	12/16/20AP, XPR-12/15/18 SHEAVE ASSEMBLY	1	E
6	5620142	12/16/20AP, XPR-12/15/18C CABLE SHEAVE PIN WELDMENT	1	A
7	5301811	HHB M6 x 1.0 x 10 FT, CL 10.9	1	-
8	5575074	10/12/16/20AP SAFETY CABLE ROLLER	1	A
9	5530756	HHB M6 x 1.0 x 25 FT, CL 10.9	1	-
10	5535357	NUT M6 x 1.0 NL, CL10.9	1	-
11	5565350	AP/GP/PCL/XPR/ PL-7000 SAFETY SHEAVE SPACER	1	C
12	5601905	12/16/20AP POWER SIDE SAFETY WELDMENT	1	B
13	5746494	10/12/16/20AP SAFETY PIVOT PIN	1	C
14	5530414	BHSC M8 x 1.25 x 25 CL10.9	1	-
15	5545202	WASHER M8 x Ø15 SL, CL10.9	1	-
16	5540047	EXTENSION SPRING Ø6.35 x 38mm	2	-
17	5530045	BHPS M5 x 0.8 x 10 FT, CL 8.8	4	-
18	5535057	NUT M8 x 1.25 x 17.5, RIVET	4	-

DO NOT SCALE DRAWING

DRAWN: RK, DATE: 02/10/2023

CHECKED: [Signature]

THIRD ANGLE PROJECTION

SMILEY FACE

PROPRIETARY AND CONFIDENTIAL
THE INFORMATION CONTAINED HEREIN IS THE PROPERTY OF BENDPAK INC. AND IS TO BE USED ONLY FOR THE PARTS LISTED HEREIN. REPRODUCTION OR TRANSMISSION OF THIS INFORMATION IN ANY FORM OR BY ANY MEANS WITHOUT THE WRITTEN PERMISSION OF BENDPAK INC. IS PROHIBITED.

1645 LEMONWOOD DR.
SANTA PAULA, CA 93060

TITLE: 16AP POWER SIDE POST ASSEMBLY

SIZE: A, DWG. NO.: 5216244, REV: C

SCALE: 1:25, SHEET 1 OF 1

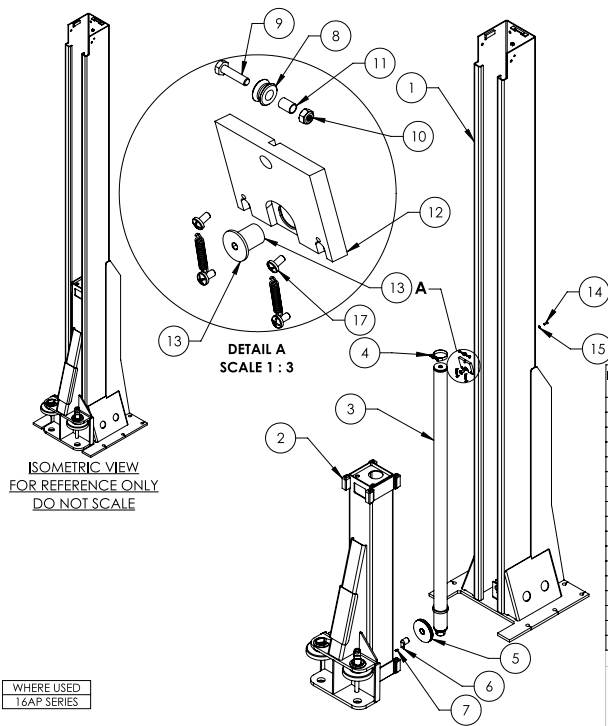

ITEM NO	PART NUMBER	DESCRIPTION	QTY	REV
1	5601996	16AP/20AP OFF SIDE POST WELDMENT	1	A
2	5216248	16AP LIFT HEAD ASSEMBLY	1	B
3	5502061	CYLINDER ASSEMBLY Ø2.75 x 75	1	B
4	5701947	CYLINDER CLAMP ASSEMBLY 80-85	1	-
5	5575113	12/16/20AP, XPR-12/15/18 SHEAVE ASSEMBLY	1	E
6	5620142	12/16/20AP, XPR-12/15/18C CABLE SHEAVE PIN WELDMENT	1	A
7	5530181	HNB M6 x 1.0 x 10 FT, CL 10.9	1	-
8	5575074	10/12/16/20AP SAFETY CABLE ROLLER	1	A
9	5530756	HNB M6 x 1.0 x 25 FT, CL 10.9	1	-
10	5535357	NUT M6 x 1.0 NL, CL10.9	1	-
11	5565350	AP/GP/PCL/XPR/ PL-7000 SAFETY SHEAVE SPACER	1	C
12	5737354	12APX OFF SIDE SAFETY BLOCK	1	C
13	5744494	10/12/16/20AP SAFETY PIVOT PIN	1	C
14	5530414	BHSH M8 x 1.25 x 25 CL10.9	1	-
15	5545202	WASHER M8 x Ø15 SL, CL10.9	1	-
16	5540047	EXTENSION SPRING Ø6.35 x 38mm	2	-
17	5530045	BHPS M5 x 0.8 x 10 FT, CL 8.8	4	-

DO NOT SCALE DRAWING

DRAWN: RK DATE: 02/10/2023
 CHECKED: OR

THIRD ANGLE PROJECTION

SMILEY FACE

PROPRIETARY AND CONFIDENTIAL
 THE INFORMATION CONTAINED ON THIS DRAWING IS THE SOLE PROPERTY OF BENDPAK INC. ANY REPRODUCTION IN WHOLE OR IN PART OF THIS DRAWING WITHOUT THE WRITTEN PERMISSION OF BENDPAK INC. IS PROHIBITED.

1645 LEMONWOOD DR.
 SANTA PAULA, CA 93060

TITLE: 16AP OFF SIDE POST ASSEMBLY

SCALE: 1:25

SIZE: DWG. NO. 5216246 REV A

SHEET 1 OF 1

WHERE USED
16AP SERIES

NOTE: UNLESS OTHERWISE SPECIFIED
 1. REFER TO MODEL FOR ADDITIONAL INFORMATION
 2. SEE SHIPPING INSTRUCTIONS FOR FINAL PACKAGING
 3. ASSEMBLE ITEMS AS SHOWN

NEXT ASSEMBLY
5246290

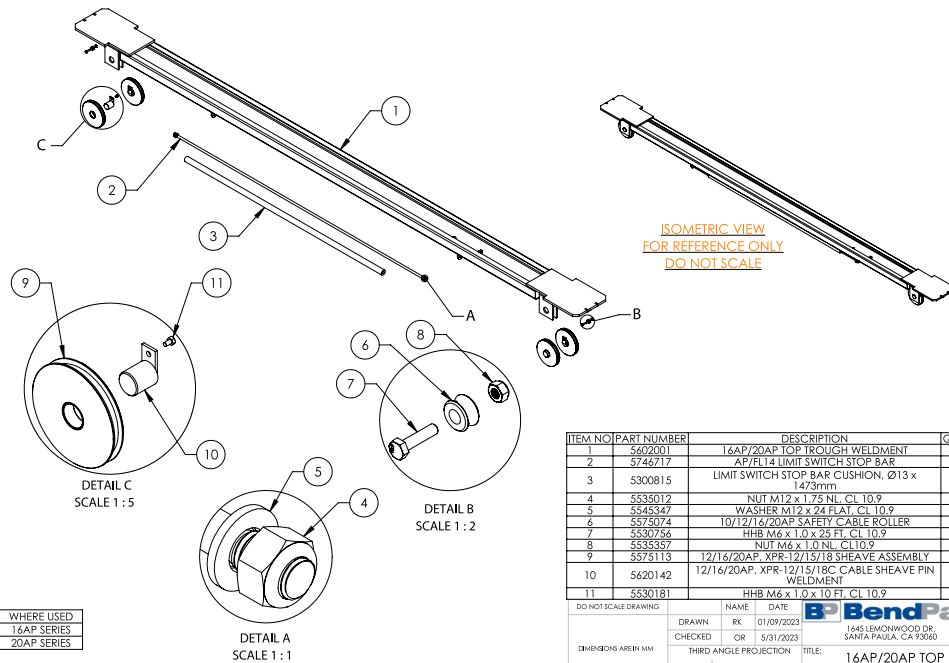

ITEM NO	PART NUMBER	DESCRIPTION	QTY	REV
1	5602001	16AP/20AP TOP TROUGH WELDMENT	1	A
2	5746717	AP/FL14 LIMIT SWITCH STOP BAR	1	A
3	5300815	LIMIT SWITCH STOP BAR CUSHION, Ø13 x 147.3mm	1	D
4	5535012	NUT M12 x 1.75 NL, CL 10.9	2	-
5	5545347	WASHER M12 x 24 FLAT, CL 10.9	2	-
6	5575074	10/12/15/20AP SAFETY CABLE ROLLER	2	A
7	5530756	HNB M6 x 1.0 x 25 FT, CL 10.9	2	-
8	5535357	NUT M6 x 1.0 NL, CL10.9	2	-
9	5575113	12/16/20AP, XPR-12/15/18 SHEAVE ASSEMBLY	4	E
10	5620142	12/16/20AP, XPR-12/15/18C CABLE SHEAVE PIN WELDMENT	4	A
11	5530181	HNB M6 x 1.0 x 10 FT, CL 10.9	4	-

DO NOT SCALE DRAWING

DRAWN: RK DATE: 01/09/2023
 CHECKED: OR

THIRD ANGLE PROJECTION

SMILEY FACE

PROPRIETARY AND CONFIDENTIAL
 THE INFORMATION CONTAINED ON THIS DRAWING IS THE SOLE PROPERTY OF BENDPAK INC. ANY REPRODUCTION IN WHOLE OR IN PART OF THIS DRAWING WITHOUT THE WRITTEN PERMISSION OF BENDPAK INC. IS PROHIBITED.

1645 LEMONWOOD DR.
 SANTA PAULA, CA 93060

TITLE: 16AP/20AP TOP TROUGH ASSEMBLY

SCALE: 1:20

SIZE: DWG. NO. 5216250 REV A

SHEET 1 OF 2

WHERE USED
16AP SERIES
20AP SERIES

NOTE: UNLESS OTHERWISE SPECIFIED
 1. REFER TO MODEL FOR ADDITIONAL INFORMATION
 2. SEE SHIPPING INSTRUCTIONS FOR FINAL PACKAGING
 3. ASSEMBLE ITEMS AS SHOWN

NEXT ASSEMBLY
5245290
5245291

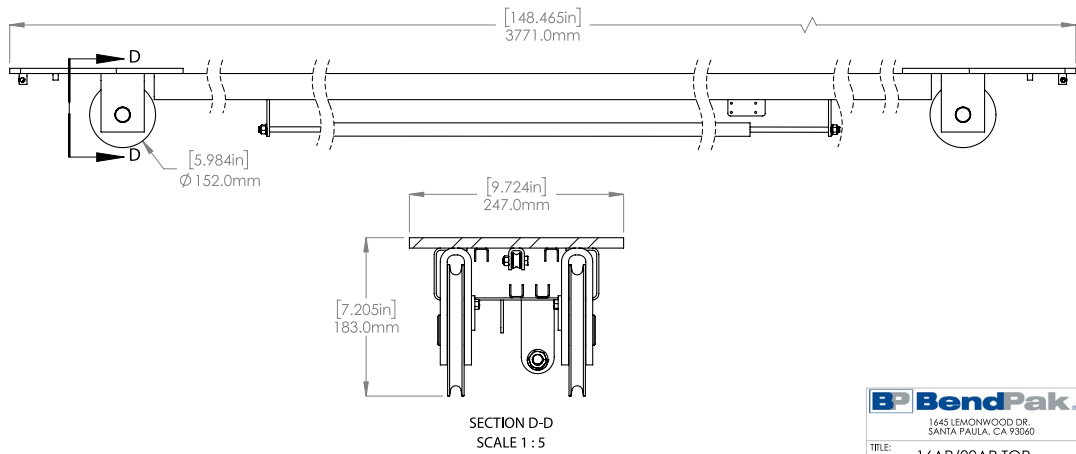

BP BendPak. 1645 LEMONWOOD DR. SANTA PAULA, CA 93060	
TITLE: 16AP/20AP TOP TROUGH ASSEMBLY	
SIZE: DWG. NO.	REV
A 5216250	A
SCALE: 1:10	SHEET 2 OF 2

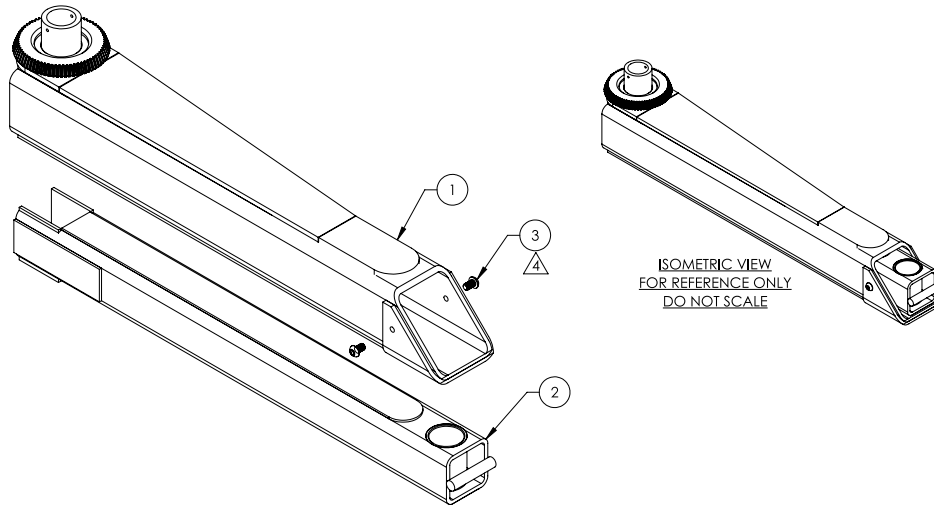

WHERE USED
16AP SERIES

- NOTE: UNLESS OTHERWISE SPECIFIED .**
- REFER TO MODEL FOR ADDITIONAL INFORMATION
 - SEE SHIPPING INSTRUCTIONS FOR FINAL PACKAGING ASSEMBLE ITEMS AS SHOWN
 - APPLY LOCTITE BLUE 242 AND CURE PER MANUFACTURE SPECIFICATION

NEXT ASSEMBLY
5260709
5260711

ITEM NO.	PART NUMBER	DESCRIPTION	QTY	REV
1	5602002	16AP ARM WELDMENT, OUTER SECTION	1	A
2	5602004	16AP ARM WELDMENT, INNER SECTION	1	A
3	5530490	BHSS M12 x 1.75 x 20 FT. CL 10.9 B.O.	2	-

DO NOT SCALE DRAWING	NAME	DATE	BP BendPak. 1645 LEMONWOOD DR. SANTA PAULA, CA 93060
DRAWN	RK	09/19/2022	
CHECKED	OR	5/31/2023	
DIMENSIONS ARE IN MM	THIRD ANGLE PROJECTION	TITLE:	16AP ARM ASSEMBLY
		SIZE: DWG. NO.	REV
		A 5216251	A
<small>PROPRIETARY AND CONFIDENTIAL THIS DRAWING IS THE PROPERTY OF BENDPAK INC. DRAWINGS OR THEir CONTENTS ARE NOT TO BE REPRODUCED OR REPRODUCED IN ANY MANNER WITHOUT THE WRITTEN PERMISSION OF BENDPAK INC.</small>		SCALE: 1:7	SHEET 1 OF 2

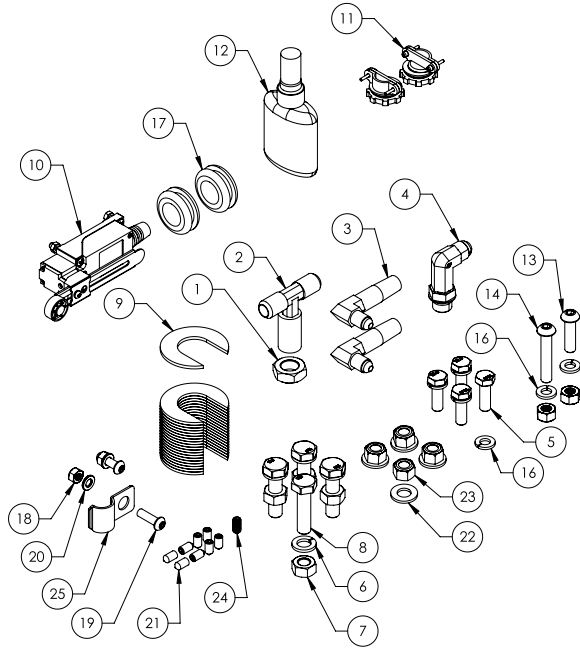

ITEM NO	PART NUMBER	DESCRIPTION	QTY	REV
1	5535022	NUT 9/16"-18 IN, Gr 5	1	-
2	5530003	FTG TEE -04 JIC -04 JIC -06 JIC	1	-
3	5550113	FTG ELB -04 NPT 1 x -04 JIC	2	-
4	5550183	FTG ELB -06 JIC -04L ORB	1	-
5	5530010	HHB M8 x 1.25 x 25 FT, CL 10.9	4	-
6	5545200	WASHER M10 x Ø18 SL, CL10.9	4	-
7	5535998	NUT M10 x 1.5, CL 10.9	4	-
8	5530302	HHB M10 x 1.5 x 40 FT, CL 10.9	4	-
9	5545535	C WASHER SHIM FOR LIFTS	20	-
10	5520088	ROCKER LIMIT SWITCH, 25A	1	-
11	5520140	ROMEX CONNECTOR 3/8 #6623	2	-
12	5580012	LIQUID PTFE THREAD SEALANT 50ml	1	-
13	5530412	BHSC M8 x 1.25 x 30 CL10.9	1	-
14	5530413	BHSC M8 x 1.25 x 45 CL10.9	1	-
15	5535001	NUT M8 x 1.25 NL, CL10.9	2	-
16	5545202	WASHER M8 x Ø15 SL, CL10.9	6	-
17	5520001	RUBBER GROMMET, 3/4 I.D.	2	-
18	5535357	NUT M6 x 1.0 NL, CL10.9	2	-
19	5530065	BHSC M6 x 1.0 x 20 FT, CL 10.9	2	-
20	5545005	WASHER M6 x 12 FLAT, CL 10.9	2	-
21	5530423	SSS M6 x 1.0 x 12 CONE, CL 10.9	8	-
22	5545341	WASHER M10 x Ø20 FLAT, CL10.9	4	-
23	5535013	NUT M10 x 1.5 NL, CL10.9	4	-
24	5530460	SSS M6 x 1.0 x 12 NL FLAT	1	-
25	5505051	Ø10mm PIPE STRAP	1	-

WHERE USED
16AP SERIES
12AP SERIES

NEXT ASSEMBLY

5250392
5250393
5250394
5250395

NOTE: UNLESS OTHERWISE SPECIFIED
1. SEE SHIPPING INSTRUCTIONS FOR FINAL PACKAGING

DO NOT SCALE DRAWING

DRAWN	NAME	DATE	
CHECKED	CA	04/13/2023	
THIRD ANGLE PROJECTION			TITLE: 16AP/20AP PARTS BAG SITE DWG. NO. 5174137 REV C
SCALE: 1:3			SHEET 1 OF 1

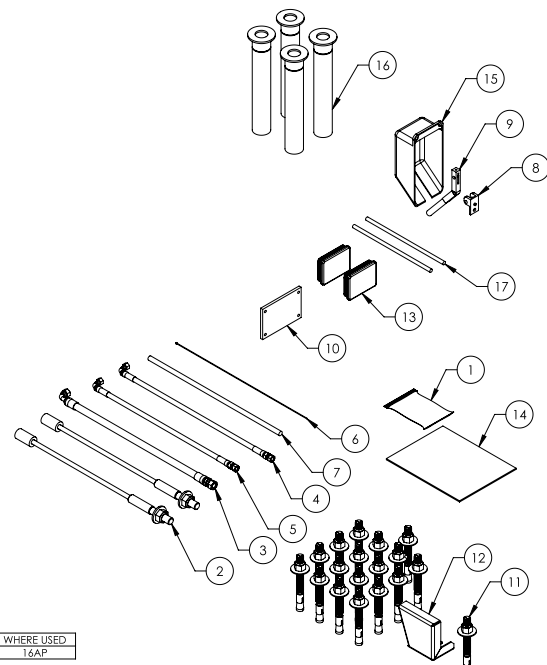

ITEM NO	PART NUMBER	DESCRIPTION	QTY	REV
1	5174137	16AP/20AP PARTS BAG	1	C
2	5595840	CABLE ASSEMBLY Ø12 x 10633mm ST	2	B
3	5570290	HYDRAULIC HOSE ASSEMBLY Ø10 x 2790mm SB	1	B
4	5570238	HYDRAULIC HOSE ASSEMBLY Ø6.4 x 3870mm SB	1	A
5	5570304	HYDRAULIC HOSE ASSEMBLY Ø6.35 x 7975mm SB	1	A
6	5593759	SAFETY CABLE Ø1.8 x 8850mm	1	B
7	5520032	CABLE AWG: 14-2 SCOW	4165mm	-
8	5700404	AP SAFETY PIVOT HOLDER	1	C
9	5761017	AP SAFETY HANDLE	1	E
10	5718003	POWER UNIT VIBRATION DAMPENER	1	B
11	5530308	AB 3/4" x 7"	18	-
12	5701946	16AP/20AP FOOT GUARD	1	A
13	5715194	POLYETHYLENE COVER BLOCK 105 x 80	2	D
14	5900377	16AP/20AP INSTALLATION MANUAL	1	-
15	5716072	AP POWER SIDE PLASTIC SAFETY COVER	1	A
16	5602006	16AP ARM LOCK PIN WELDMENT, Ø50	4	A
17	5746166	DOUBLE THREADED ROD M10 x 1.5 x 295	2	B

WHERE USED
16AP

NEXT ASSEMBLY

5260709

NOTE: UNLESS OTHERWISE SPECIFIED
1. REFER TO MODEL FOR ADDITIONAL INFORMATION
2. INSERT PARTS BAG INTO PARTS BOX FOR SHIPMENT
3. HOSES AND CABLES SHOWN REPRESENTATIONAL FORM

DO NOT SCALE DRAWING

DRAWN	NAME	DATE	
CHECKED	CA	04/20/2023	
THIRD ANGLE PROJECTION			TITLE: 16AP PARTS BOX #1 SITE DWG. NO. 5250392 REV C
SCALE: 1:10			SHEET 1 OF 1

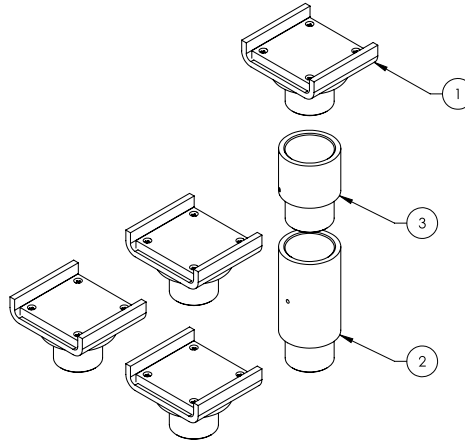
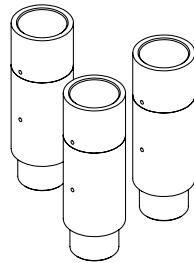

WHERE USED
16AP SERIES
20AP SERIES

- NOTE: UNLESS OTHERWISE SPECIFIED:**
1. REFER TO MODEL FOR ADDITIONAL INFORMATION
 2. SEE COLORS & GRAPHICS FOR LABEL PLACEMENT
 3. SEE SHIPPING INSTRUCTIONS FOR FINAL PACKAGING

ITEM NO	PART NUMBER	DESCRIPTION	QTY	REV
1	5215702	CRADLE LIFT PAD LARGE ADAPTER ASSEMBLY	4	F
2	5746193	ARM ADAPTER, LONG	4	E
3	5746192	ARM ADAPTER, MEDIUM	4	F

DO NOT SCALE DRAWING

DRAWN	NAME	DATE
	TM	02/07/2024

CHECKED

DIMENSIONS ARE IN MM

THIRD ANGLE PROJECTION

PROPRIETARY AND CONFIDENTIAL
THE INFORMATION CONTAINED IN THIS DRAWING IS THE SOLE PROPERTY OF BENDPAK INC. ANY REPRODUCTION IN PART OR AS A WHOLE WITHOUT THE WRITTEN PERMISSION OF BENDPAK INC. IS PROHIBITED.

16/20AP PARTS BOX #2

SCALE: 1:5

SHEET 1 OF 1

NEXT ASSEMBLY
5260709
5260710
5260711
5260714

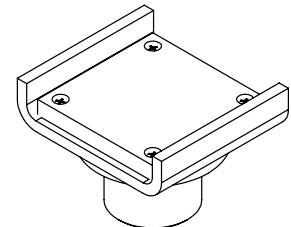
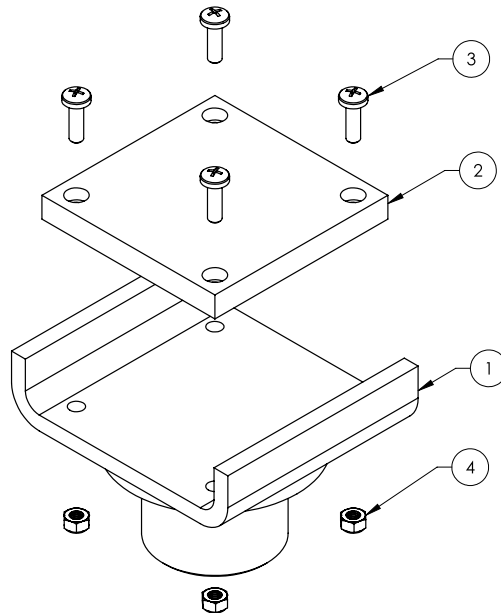

ISOMETRIC VIEW
FOR REFERENCE ONLY
DO NOT SCALE

WHERE USED
12AP SERIES
16AP SERIES
20AP SERIES
XPR-12FDL SERIES
XPR-12CL SERIES
XPR-15 SERIES
XPR-18 SERIES

- NOTE: UNLESS OTHERWISE SPECIFIED:**
1. REFER TO MODEL FOR ADDITIONAL INFORMATION
 2. SEE SHIPPING INSTRUCTIONS FOR FINAL PACKAGING
 3. ASSEMBLE ITEMS AS SHOWN

ITEM NO	PART NUMBER	DESCRIPTION	QTY	REV
1	5601000	CRADLE LIFT PAD WELDMENT	1	D
2	5715020	CRADLE LIFT PAD LARGE POLYURETHANE PAD	1	C
3	5530022	PHPS M6 x 1 x 20mm ZPL	4	--
4	5535357	NUT M6 x 1.0 NL	4	--

DO NOT SCALE DRAWING

DRAWN	NAME	DATE
JM		06/24/2015

CHECKED

DIMENSIONS ARE IN MM

THIRD ANGLE PROJECTION

PROPRIETARY AND CONFIDENTIAL
THE INFORMATION CONTAINED IN THIS DRAWING IS THE SOLE PROPERTY OF BENDPAK INC. ANY REPRODUCTION IN PART OR AS A WHOLE WITHOUT THE WRITTEN PERMISSION OF BENDPAK INC. IS PROHIBITED.

CRADLE LIFT PAD LARGE ADAPTER ASSEMBLY

SCALE: 1:2

SHEET 1 OF 1

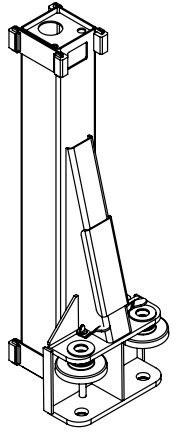

ISOMETRIC VIEW
FOR REFERENCE ONLY
DO NOT SCALE

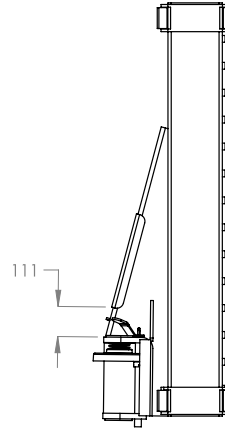
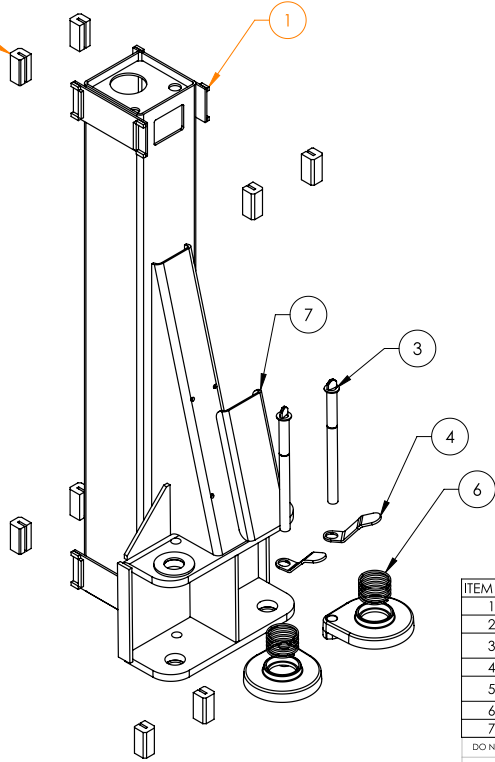

ITEM NO	PART NUMBER	DESCRIPTION	QTY	REV
1	5601997	16AP LIFT HEAD WELDMENT	1	B
2	5716001	2 POST GUIDE BLOCK	8	H
3	5602031	16AP ARM LOCK GUIDE ROD WELDMENT, GROOVE	2	A
4	5701700	AP ARM LOCK RELEASE HANDLE	2	C
5	5701955	16AP/20AP ARM INTERNAL FULL CIRCLE GEAR STOP, THREADED HOLES	2	A
6	5540059	COMPRESSION SPRING Ø79 x 40mm	2	-
7	5930004	12/16/20AP LIFT HEAD GUSSET COVER	1	B

WHERE USED
16AP SERIES

NOTE: UNLESS OTHERWISE SPECIFIED:

1. REFER TO MODEL FOR ADDITIONAL INFORMATION
2. SEE SHIPPING INSTRUCTIONS FOR FINAL PACKAGING
3. ASSEMBLE ITEMS AS SHOWN

NEXT ASSEMBLY
5216244
5216246

DO NOT SCALE DRAWING

NAME: _____ DATE: _____

DRAWN: RK 09/19/2022

CHECKED: _____

1645 LEMONWOOD DR.
SANTA PAULA, CA 93060

THIRD ANGLE PROJECTION

TITLE: 16AP LIFT HEAD ASSEMBLY

SIZE: A DWG. NO. 5216248 REV. C

SCALE: 1:12 SHEET 1 OF 2

PROPRIETARY AND CONFIDENTIAL
THE INFORMATION CONTAINED IN THIS DRAWING IS THE SOLE PROPERTY OF BENDPAK INC. ANY REPRODUCTION IN PART OR AS A WHOLE WITHOUT THE WRITTEN PERMISSION OF BENDPAK INC. IS PROHIBITED.

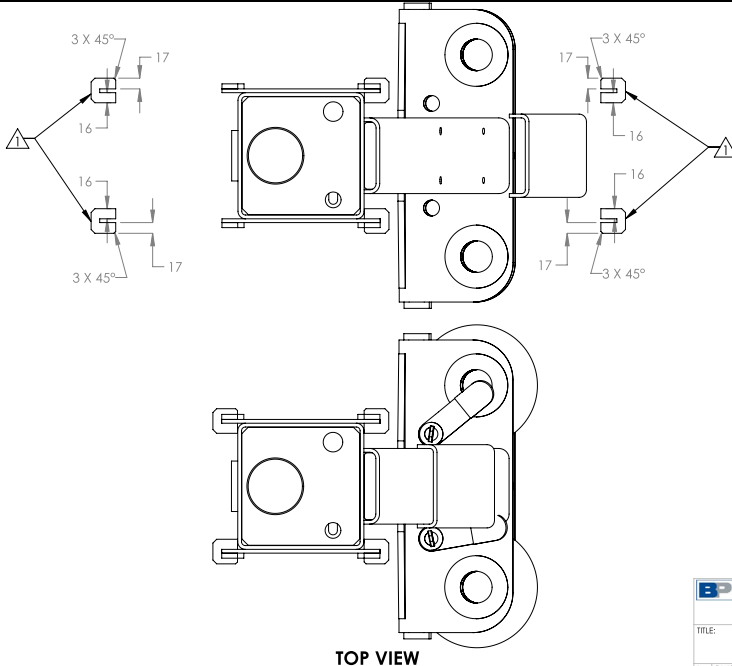

TOP VIEW

NOTE: UNLESS OTHERWISE SPECIFIED:
 NOTE ORIENTATION OF PLASTIC GUIDE BLOCK

BendPak.
 1645 LEMONWOOD DR.
 SANTA PAULA, CA 93060

TITLE: 16AP LIFT HEAD ASSEMBLY

SIZE: A DWG. NO. 5216248 REV. C

SCALE: 1:10 SHEET 2 OF 2

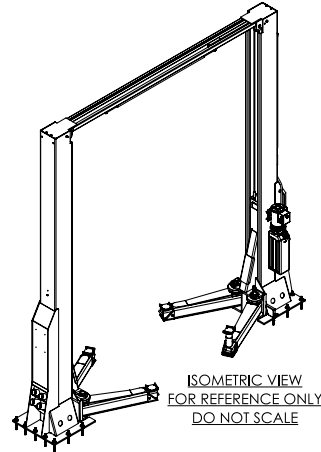
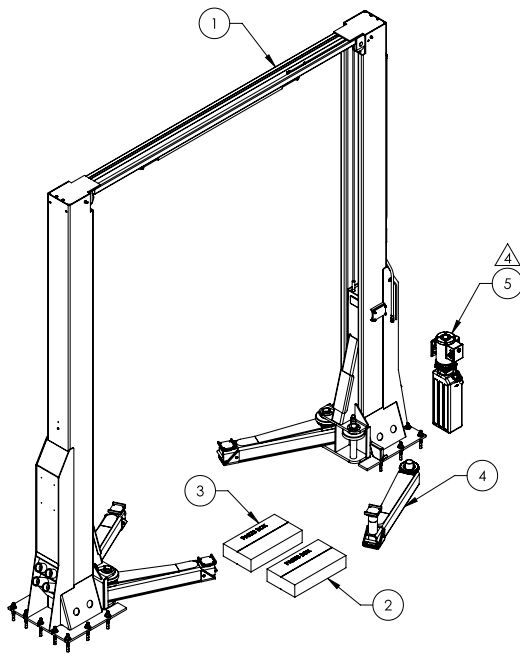

NOTE: UNLESS OTHERWISE SPECIFIED

1. REFER TO MODEL FOR ADDITIONAL INFORMATION
 2. SEE COLORS & GRAPHICS FOR LABEL PLACEMENT
 3. SEE SHIPPING INSTRUCTIONS FOR FINAL PACKAGING
4. POWER UNIT REFERENCE ON PURCHASE ORDER

ITEM NO.	PART NUMBER	DESCRIPTION	QTY.	REV.
1	5245291	20AP LIFT SUPERSTRUCTURE	1	C
2	5250393	20AP PARTS BOX #1	1	C
3	5250396	16/20AP PARTS BOX #2	1	A
4	5216252	20AP ARM ASSEMBLY	4	A
5	REF	POWER UNIT	1	-

DO NOT SCALE DRAWING	NAME	DATE	 1645 LEMONWOOD DR. SANTA PAULA, CA 93060
	DRAWN RK	02/10/2023	
DIMENSIONS ARE IN MM	CHECKED		TITLE: 20AP PRODUCTION LIFT VER A SIZE: DWG. NO. 5260710 REV C SCALE: 1:35 SHEET 1 OF 3
 THIRD ANGLE PROJECTION			

PROPERTY AND CONFIDENTIALITY OF BENDPAK INC. THIS DRAWING IS THE PROPERTY OF BENDPAK INC. ANY REPRODUCTION IN PART OR AS A WHOLE WITHOUT THE WRITTEN PERMISSION OF BENDPAK INC. IS PROHIBITED.

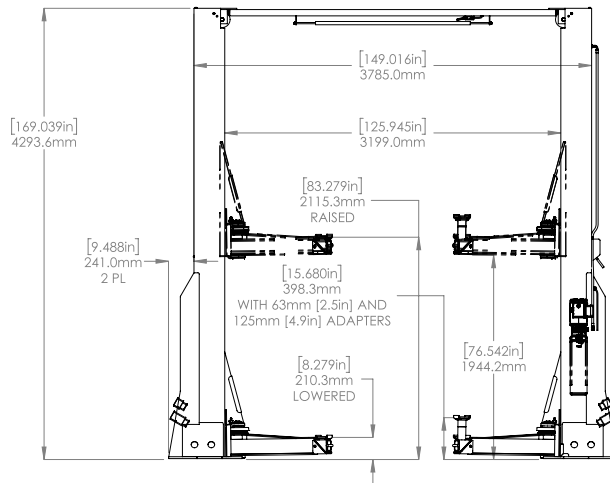
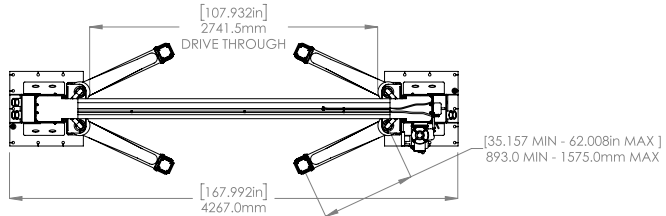

 1645 LEMONWOOD DR. SANTA PAULA, CA 93060			
TITLE: 20AP PRODUCTION LIFT VER A			
SIZE: DWG. NO.	5260710	REV	C
SCALE: 1:36		SHEET 2 OF 3	

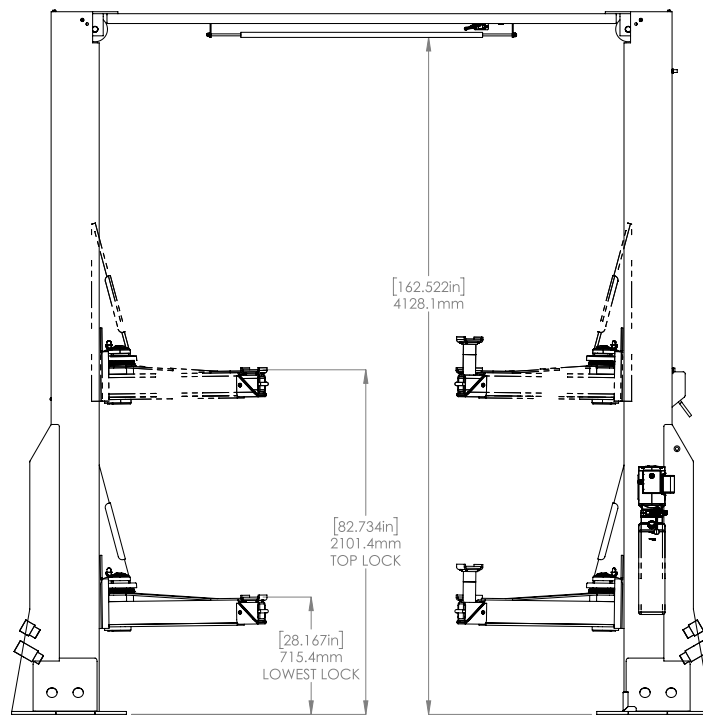

1. SAFETY LOCK POSITIONS: 15
2. SPACED EVERY: 99.0mm / 3.898"

BPBendPak.
1645 LEMONWOOD DR.
SANTA PAULA, CA 93060

TITLE: 20AP PRODUCTION LIFT VER A

SIZE: DWG. NO.	REV
A 5260710	C

SCALE: 1:25 SHEET 3 OF 3

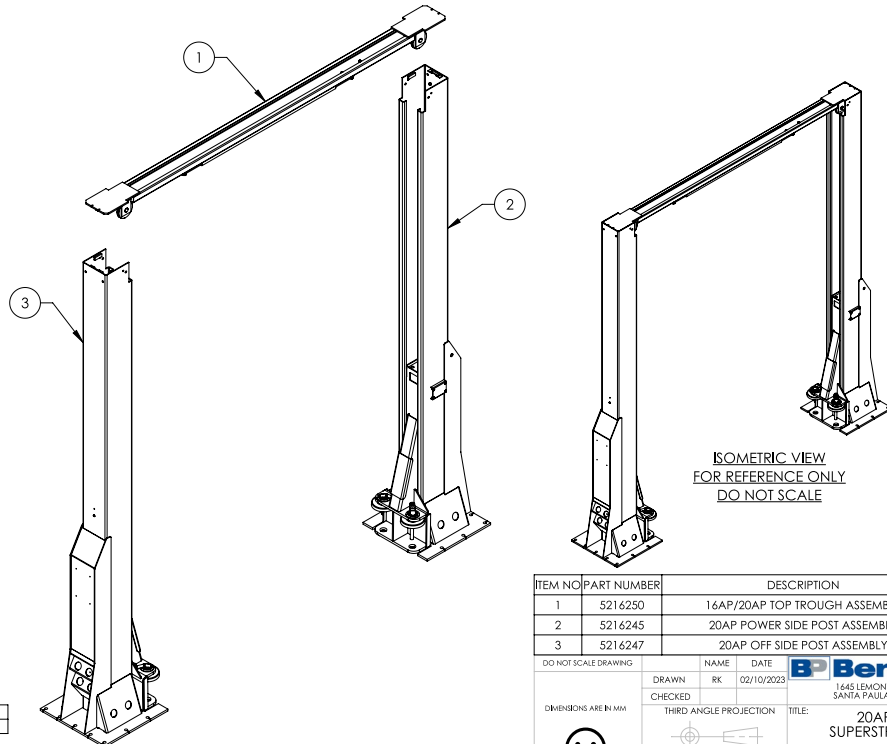

WHERE USED
20AP SERIES

- NOTE: UNLESS OTHERWISE SPECIFIED**
1. REFER TO MODEL FOR ADDITIONAL INFORMATION
 2. SEE SHIPPING INSTRUCTIONS FOR FINAL PACKAGING

NEXT ASSEMBLY
5260710
5260714

ITEM NO	PART NUMBER	DESCRIPTION	QTY	REV
1	5216250	16AP/20AP TOP TROUGH ASSEMBLY	1	A
2	5216245	20AP POWER SIDE POST ASSEMBLY	1	C
3	5216247	20AP OFF SIDE POST ASSEMBLY	1	B

DO NOT SCALE DRAWING	NAME	DATE	BPBendPak. 1645 LEMONWOOD DR. SANTA PAULA, CA 93060
DRAWN	RK	02/10/2023	
CHECKED			
DIMENSIONS ARE IN MM	THIRD ANGLE PROJECTION	TITLE: 20AP LIFT SUPERSTRUCTURE	
	PROPRIETARY AND CONFIDENTIAL THE INFORMATION CONTAINED HEREIN IS THE PROPERTY OF BENDPAK INC. ANY REPRODUCTION IN PART OR AS A WHOLE WITHOUT THE WRITTEN PERMISSION OF BENDPAK INC. IS PROHIBITED.	SIZE: DWG. NO.	REV
		A 5245291	C
		SCALE: 1:32	SHEET 1 OF 1

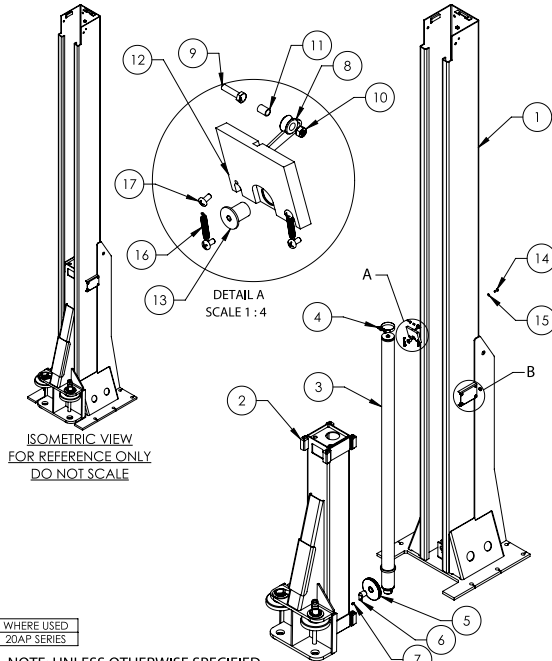

ISOMETRIC VIEW
FOR REFERENCE ONLY
DO NOT SCALE

WHERE USED
20AP SERIES

- NOTE: UNLESS OTHERWISE SPECIFIED**
1. REFER TO MODEL FOR ADDITIONAL INFORMATION
 2. SEE SHIPPING INSTRUCTIONS FOR FINAL PACKAGING ASSEMBLE ITEMS AS SHOWN
 3. ASSEMBLE ITEMS AS SHOWN
- ▲ 4. INSTALL RIVET NUTS INTO POST BRACKET AS SHOWN

NEXT ASSEMBLY
5245291

ITEM NO	PART NUMBER	DESCRIPTION	QTY	REV
1	5601999	16AP/20AP POWER SIDE POST WELDMENT	1	B
2	5216249	20AP LIFT HEAD ASSEMBLY	1	B
3	5502061	CYLINDER ASSEMBLY Ø2.75 x 75	1	B
4	5701947	CYLINDER CLAMP ASSEMBLY 80-85	1	-
5	5575113	12/16/20AP_XPR-12/15/18 SHEAVE ASSEMBLY	1	E
6	5620142	12/16/20AP_XPR-12/15/18C CABLE SHEAVE PIN WELDMENT	1	A
7	5530181	HHB M6 x 1.0 x 10 FT. CL 10.9	1	-
8	5575074	10/12/16/20AP SAFETY CABLE ROLLER	1	A
9	5530756	HHB M6 x 1.0 x 25 FT. CL 10.9	1	-
10	5535357	NUT M6 x 1.0 NL. CL10.9	1	-
11	5565350	AP/GP/PCL/XPR/ PL-7000 SAFETY SHEAVE SPACER	1	C
12	5601905	12/16/20AP POWER SIDE SAFETY WELDMENT	1	B
13	5746494	10/12/16/20AP SAFETY PIVOT PIN	1	C
14	5530414	BHSC M8 x 1.25 x 25 CL10.9	1	-
15	5545202	WASHER M8 x Ø15 SL CL10.9	1	-
16	5540047	EXTENSION SPRING Ø6.35 x 38mm	2	-
17	5530045	BHPS M5 x 0.8 x 10 FT. CL 8.8	4	-
18	5535057	NUT M8 x 1.25 x 17.5. RIVET	4	-

DO NOT SCALE DRAWING

DRAWN: RK DATE: 02/10/2023

CHECKED: []

THIRD ANGLE PROJECTION

SMILEY FACE

1645 LEMONWOOD DR. SANTA PAULA, CA 93060

TITLE: 20AP POWER SIDE POST ASSEMBLY

SIZE: A DWG. NO.: 5216245 REV: C

SCALE: 1:25 SHEET 1 OF 1

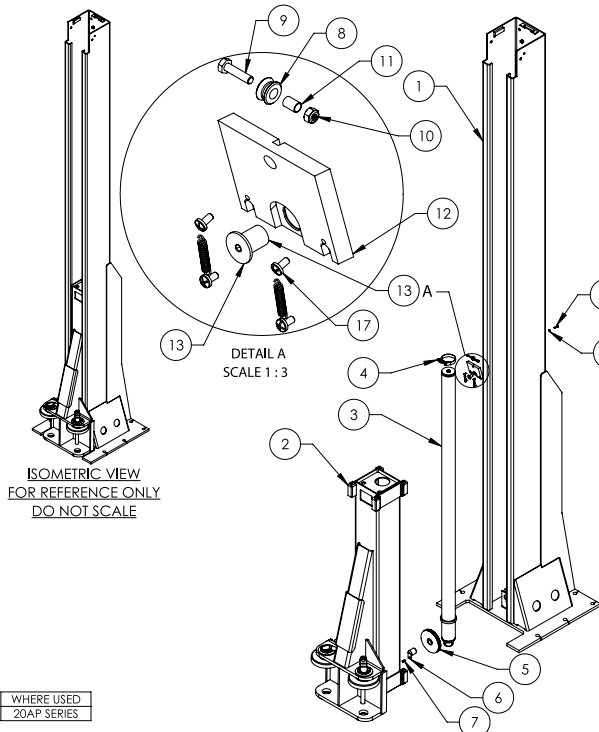

ISOMETRIC VIEW
FOR REFERENCE ONLY
DO NOT SCALE

WHERE USED
20AP SERIES

- NOTE: UNLESS OTHERWISE SPECIFIED**
1. REFER TO MODEL FOR ADDITIONAL INFORMATION
 2. SEE SHIPPING INSTRUCTIONS FOR FINAL PACKAGING ASSEMBLE ITEMS AS SHOWN
 3. ASSEMBLE ITEMS AS SHOWN

NEXT ASSEMBLY
5245291

ITEM NO	PART NUMBER	DESCRIPTION	QTY	REV
1	5601999	16AP/20AP OFF SIDE POST WELDMENT	1	A
2	5216249	20AP LIFT HEAD ASSEMBLY	1	B
3	5502061	CYLINDER ASSEMBLY Ø2.75 x 75	1	B
4	5701947	CYLINDER CLAMP ASSEMBLY 80-85	1	-
5	5575113	12/16/20AP_XPR-12/15/18 SHEAVE ASSEMBLY	1	E
6	5620142	12/16/20AP_XPR-12/15/18C CABLE SHEAVE PIN WELDMENT	1	A
7	5530181	HHB M6 x 1.0 x 10 FT. CL 10.9	1	-
8	5575074	10/12/16/20AP SAFETY CABLE ROLLER	1	A
9	5530756	HHB M6 x 1.0 x 25 FT. CL 10.9	1	-
10	5535357	NUT M6 x 1.0 NL. CL10.9	1	-
11	5565350	AP/GP/PCL/XPR/ PL-7000 SAFETY SHEAVE SPACER	1	C
12	5737354	12APX OFF SIDE SAFETY BLOCK	1	C
13	5746494	10/12/16/20AP SAFETY PIVOT PIN	1	C
14	5530414	BHSC M8 x 1.25 x 25 CL10.9	1	-
15	5545202	WASHER M8 x Ø15 SL CL10.9	1	-
16	5540047	EXTENSION SPRING Ø6.35 x 38mm	2	-
17	5530045	BHPS M5 x 0.8 x 10 FT. CL 8.8	4	-

DO NOT SCALE DRAWING

DRAWN: RK DATE: 02/10/2023

CHECKED: []

THIRD ANGLE PROJECTION

SMILEY FACE

1645 LEMONWOOD DR. SANTA PAULA, CA 93060

TITLE: 20AP OFF SIDE POST ASSEMBLY

SIZE: A DWG. NO.: 5216247 REV: B

SCALE: 1:25 SHEET 1 OF 1

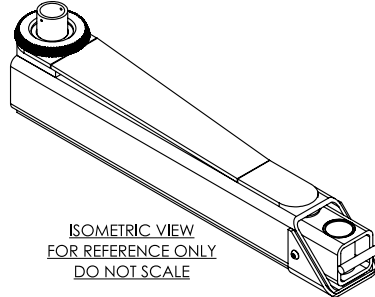
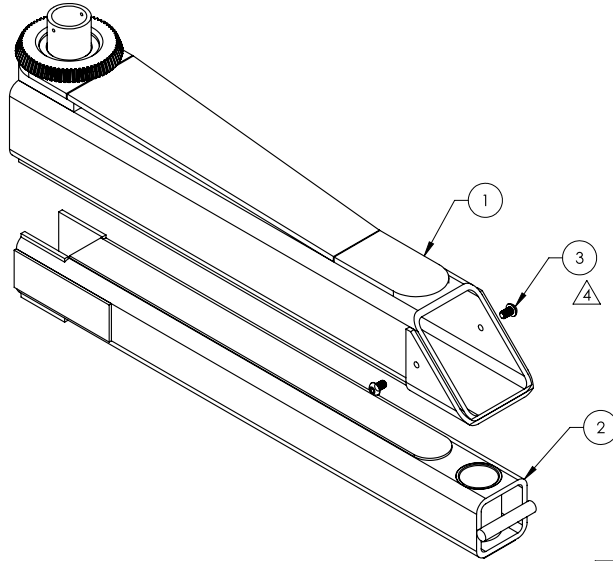

WHERE USED
20AP SERIES

NOTE: UNLESS OTHERWISE SPECIFIED

1. REFER TO MODEL FOR ADDITIONAL INFORMATION
2. REFER TO MODEL FOR ADDITIONAL INFORMATION
3. SEE SHIPPING INSTRUCTIONS FOR FINAL PACKAGING ASSEMBLE ITEMS AS SHOWN
4. APPLY LOCTITE BLUE 242 AND CURE PER MANUFACTURE SPECIFICATION

NEXT ASSEMBLY
5260710
5260714

ITEM NO	PART NUMBER	DESCRIPTION	QTY	REV
1	5602003	20AP ARM WELDMENT, OUTER SECTION	1	A
2	5602005	20AP ARM WELDMENT, INNER SECTION	1	A
3	5530490	BHSS M12 x 1.75 x 20 FT. CL 10.9 B.O.	2	-

DO NOT SCALE DRAWING		NAME	DATE	BendPak 1645 LEMONWOOD DR. SANTA PAULA, CA 93060
DRAWN	OR	CA	02/10/2023	
DIMENSIONS ARE IN MM		CHECKED	OR	5/31/2023
THIRD ANGLE PROJECTION		TITLE:		20AP ARM ASSEMBLY
SIZE		DWG. NO.	REV	
A		5216252	A	
SCALE: 1:7				SHEET 1 OF 2

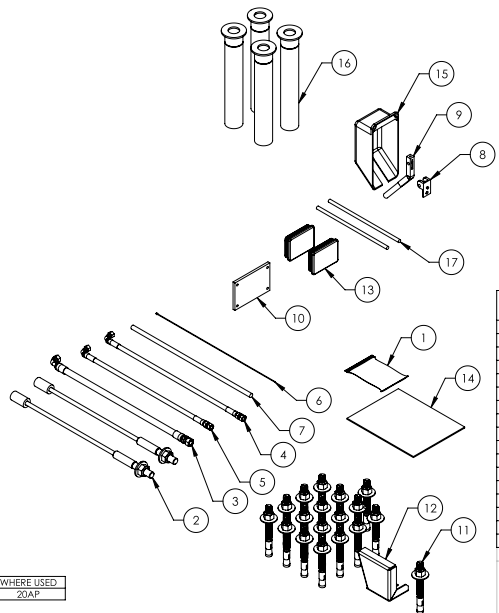

WHERE USED
20AP

NOTE: UNLESS OTHERWISE SPECIFIED

1. REFER TO MODEL FOR ADDITIONAL INFORMATION
2. INSERT PARTS BAG INTO PARTS BOX FOR SHIPMENT
3. HOSES AND CABLES SHOWN REPRESENTATIONAL FORM

ITEM NO	PART NUMBER	DESCRIPTION	QTY	REV
1	5174137	16AP/20AP PARTS BAG	1	C
2	5598840	CABLE ASSEMBLY Ø12 x 1063mm ST	2	B
3	5570290	HYDRAULIC HOSE ASSEMBLY Ø10 x 2790mm SB	1	B
4	5570238	HYDRAULIC HOSE ASSEMBLY Ø6.4 x 3870mm SB	1	A
5	5570304	HYDRAULIC HOSE ASSEMBLY Ø6.35 x 7975mm SB	1	A
6	5595759	SAFETY CABLE Ø1.8 x 8850mm	1	B
7	5520352	CABLE AWC 14-2, 300W	4165mm	-
8	5704044	AP SAFETY PIVOT HOLDER	1	C
9	5761017	AP SAFETY HANDLE	1	E
10	5715003	POWER UNIT VIBRATION DAMPENER	1	B
11	5530308	AB 3/4" x 7"	18	-
12	5701946	16AP/20AP FOOT GUARD	1	A
13	5715195	POLYETHYLENE COVER BLOCK 105 x 80	2	D
14	5900377	16AP/20AP INSTALLATION MANUAL	1	-
15	5716072	AP POWER SIDE PLASTIC SAFETY COVER	1	A
16	5602007	20AP ARM LOCK PIN WELDMENT, Ø54	4	A
17	5746164	DOUBLE THREADED ROD M10 x 1.5 x 295	2	B

DO NOT SCALE DRAWING		NAME	DATE	BendPak 1645 LEMONWOOD DR. SANTA PAULA, CA 93060
DRAWN	OR	CA	04/21/2023	
DIMENSIONS ARE IN MM		CHECKED	OR	
THIRD ANGLE PROJECTION		TITLE:		20AP PARTS BOX #1
SIZE		DWG. NO.	REV	
A		5250393	C	
SCALE: 1:10				SHEET 1 OF 1

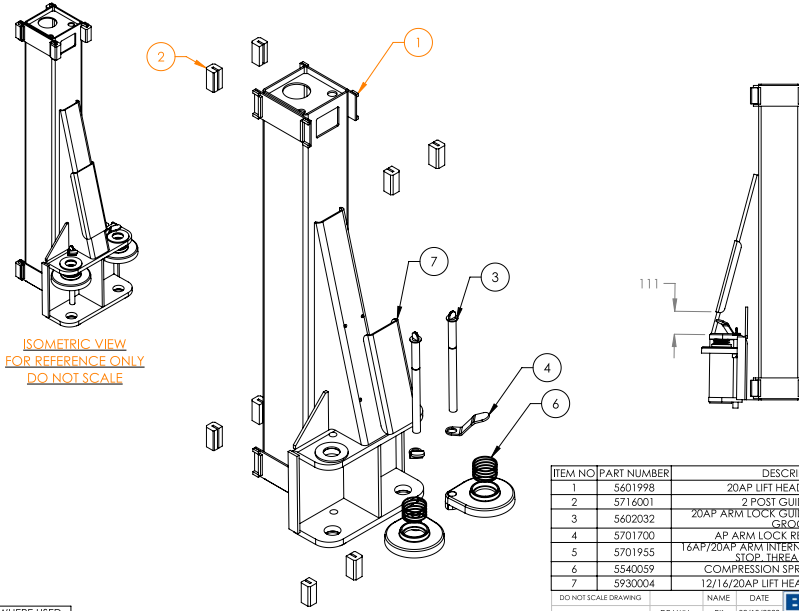

ISOMETRIC VIEW
FOR REFERENCE ONLY
DO NOT SCALE

WHERE USED
20AP SERIES

- NOTE: UNLESS OTHERWISE SPECIFIED**
1. REFER TO MODEL FOR ADDITIONAL INFORMATION
 2. SEE SHIPPING INSTRUCTIONS FOR FINAL PACKAGING
 3. ASSEMBLE ITEMS AS SHOWN

ITEM NO	PART NUMBER	DESCRIPTION	QTY	REV
1	5601998	20AP LIFT HEAD WELDMENT	1	B
2	5716001	2 POST GUIDE BLOCK	8	H
3	5602032	20AP ARM LOCK GUIDE ROD WELDMENT, GROOVE	2	A
4	5701700	AP ARM LOCK RELEASE HANDLE	2	C
5	5701955	16AP/20AP ARM INTERNAL FULL CIRCLE GEAR, STEEL, THREADED HOLES	2	A
6	5540059	COMPRESSION SPRING Ø379 x 40mm	2	-
7	5930004	12/16/20AP LIFT HEAD GUSSET COVER	1	B

DO NOT SCALE DRAWING

DRAWN: RK DATE: 02/10/2023

CHECKED:

1645 LEMONWOOD DR. SANTA PAULA, CA 93060

BendPak

THIRD ANGLE PROJECTION

TITLE: 20AP LIFT HEAD ASSEMBLY

SIZE: DWG. NO. 5216249

REV: C

SCALE: 1:12 SHEET 1 OF 2

PROPRIETARY AND CONFIDENTIAL
THE INFORMATION CONTAINED HEREIN IS THE SOLE PROPERTY OF BENDPAK INC. ANY REPRODUCTION OR TRANSMISSION WITHOUT PERMISSION IS PROHIBITED.

SMILEY FACE

NEXT ASSEMBLY
5216245
5216247

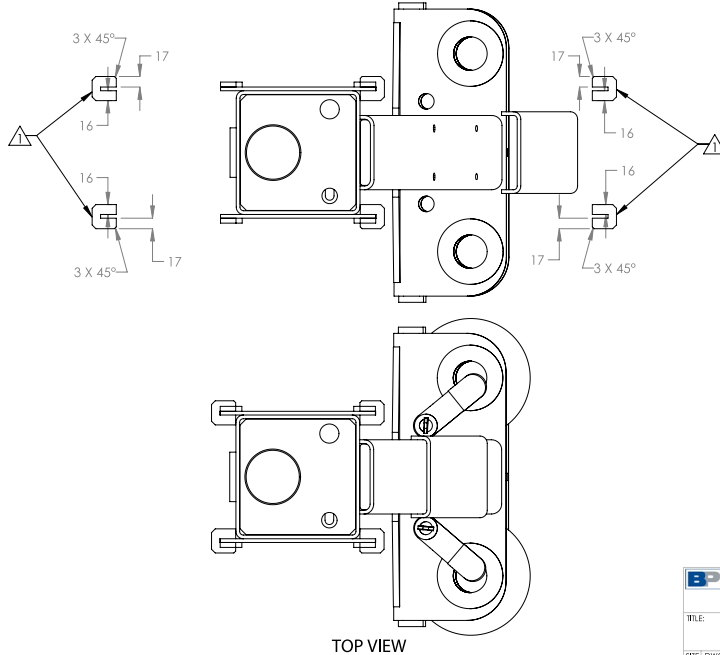

NOTE: UNLESS OTHERWISE SPECIFIED

△ NOTE ORIENTATION OF PLASTIC GUIDE BLOCK

BendPak

1645 LEMONWOOD DR. SANTA PAULA, CA 93060

TITLE: 20AP LIFT HEAD ASSEMBLY

SIZE: DWG. NO. 5216249

REV: C

SCALE: 1:10 SHEET 2 OF 2

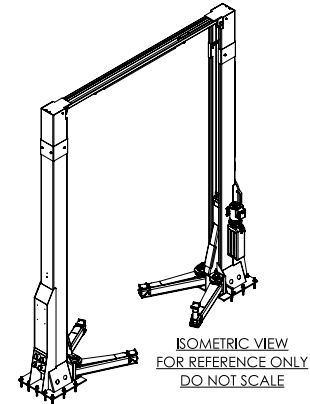
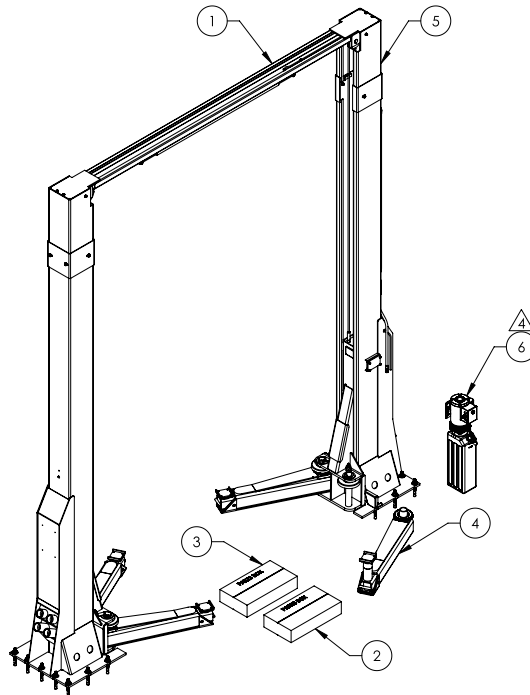

- NOTE: UNLESS OTHERWISE SPECIFIED**
1. REFER TO MODEL FOR ADDITIONAL INFORMATION
 2. SEE COLORS & GRAPHICS FOR LABEL PLACEMENT
 3. SEE SHIPPING INSTRUCTIONS FOR FINAL PACKAGING
 4. POWER UNIT REFERENCE ON PURCHASE ORDER

ITEM NO	PART NUMBER	DESCRIPTION	QTY	REV
1	5245291	20AP LIFT SUPERSTRUCTURE	1	C
2	5250395	20AP-192 PARTS BOX #1	1	C
3	5250396	16/20AP PARTS BOX #2	1	A
4	5216252	20AP ARM ASSEMBLY	4	A
5	5216204	12APX/16/20AP-192 POST EXTENSION ASSEMBLY	2	C
6	REF	POWER UNIT	1	-

DO NOT SCALE DRAWING

DRAWN	NAME	DATE	
RK		02/10/2023	
CHECKED			1645 LEMONWOOD DR. SANTA PAULA, CA 93060

THIRD ANGLE PROJECTION

SMILEY FACE

PROPRIETARY AND CONFIDENTIAL: THE INFORMATION CONTAINED BY THIS DRAWING IS THE SOLE PROPERTY OF BENDPAK INC. ANY REPRODUCTION IN WHOLE OR IN PART WITHOUT THE WRITTEN PERMISSION OF BENDPAK INC. IS PROHIBITED.

TITLE	SIZE	DWG. NO.	REV
20AP-192 PRODUCTION LIFT VER A	A	5260714	C

SCALE: 1:35 SHEET 1 OF 3

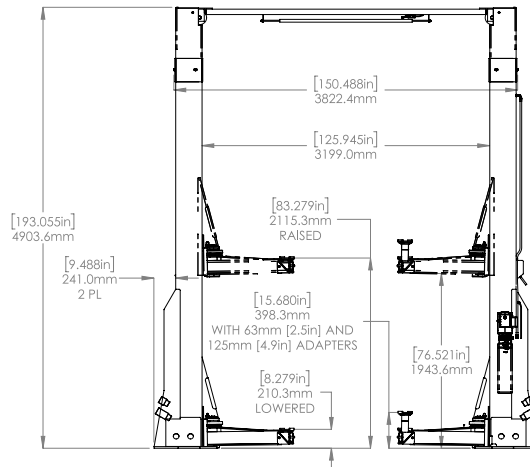
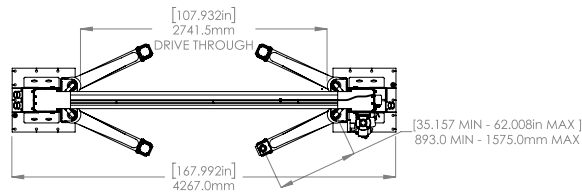

1645 LEMONWOOD DR. SANTA PAULA, CA 93060			
TITLE	SIZE	DWG. NO.	REV
20AP-192 PRODUCTION LIFT VER A	A	5260714	C
SCALE: 1:40			SHEET 2 OF 3

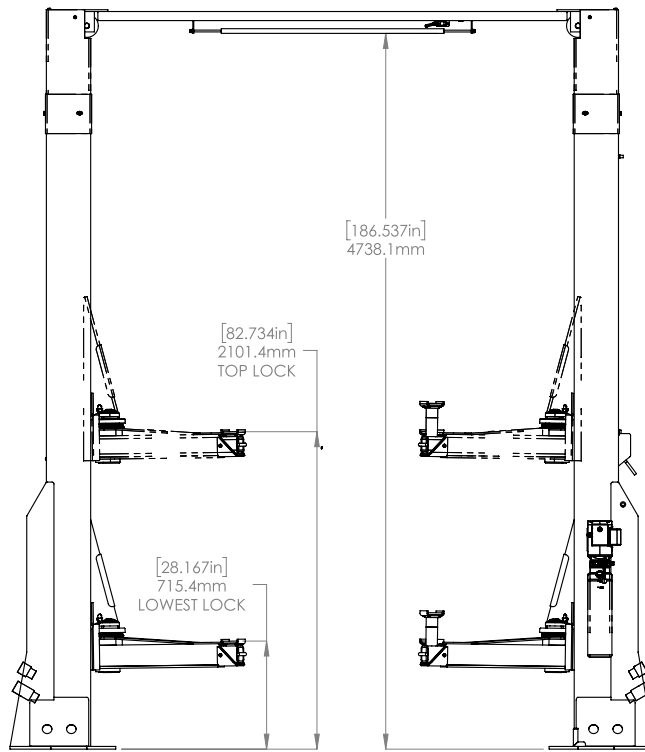

1. SAFETY LOCK POSITIONS: 15
2. SPACED EVERY: 99.0mm / 3.898"

BendPak.
 1645 LEMONWOOD DR.
 SANTA PAULA, CA 93060

TITLE: 20AP-192 PRODUCTION LIFT VER A

SIZE	DWG. NO.	REV
A	5260714	C
SCALE: 1:30		SHEET 3 OF 3

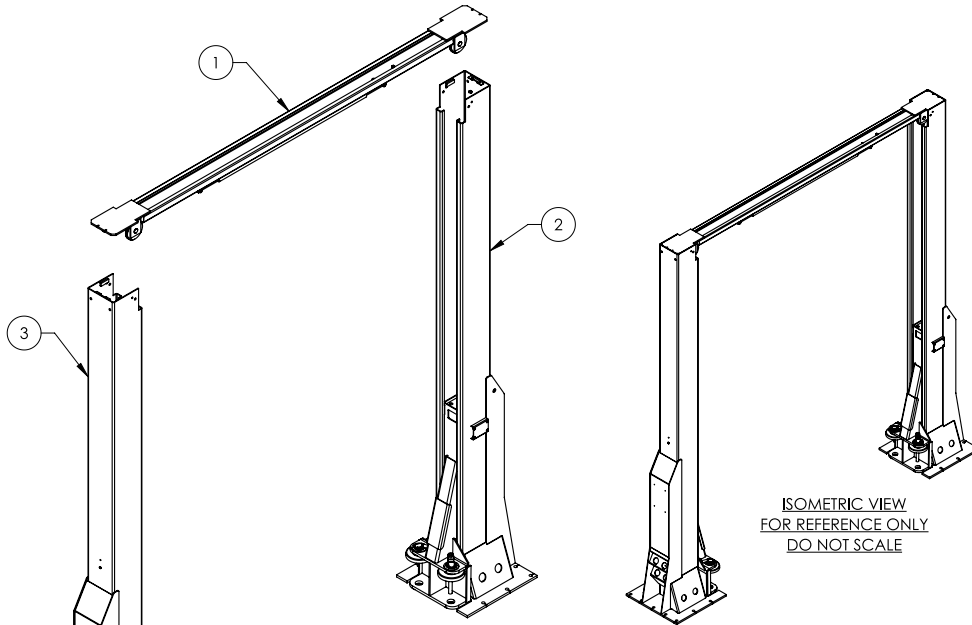

WHERE USED
20AP SERIES

NOTE: UNLESS OTHERWISE SPECIFIED
 1. REFER TO MODEL FOR ADDITIONAL INFORMATION
 2. SEE SHIPPING INSTRUCTIONS FOR FINAL PACKAGING

NEXT ASSEMBLY
 5260710
 5260714

ITEM NO	PART NUMBER	DESCRIPTION	QTY	REV
1	5216250	16AP/20AP TOP TROUGH ASSEMBLY	1	A
2	5216245	20AP POWER SIDE POST ASSEMBLY	1	C
3	5216247	20AP OFF SIDE POST ASSEMBLY	1	B

DO NOT SCALE DRAWING		NAME	DATE	BendPak. 1645 LEMONWOOD DR. SANTA PAULA, CA 93060
DRAWN	RK	02/10/2023		
DIMENSIONS ARE IN MM		CHECKED		
THIRD ANGLE PROJECTION		TITLE: 20AP LIFT SUPERSTRUCTURE		
		SIZE	DWG. NO.	REV
		A	5245291	C
		SCALE: 1:32		SHEET 1 OF 1

Automotive Lift Institute (ALI) Store

You probably checked the [ALI's Directory of Certified Lifts](http://www.autolift.org/ali-directory-of-certified-lifts/) before making your most recent Lift purchase, but did you know the [ALI Store](http://www.autolift.org/ali-store/) offers a wide variety of professional, easy-to-use, and reasonably priced training and safety materials that will make your garage a safer place to work?

The ALI Store is your trusted source for workplace safety!



Lifting It Right Online Certificate Course. Make *sure* you and your people are lifting vehicles the right way.



ALI Lift Inspector Certification Program Registration. Become a ALI Certified Lift Inspector.

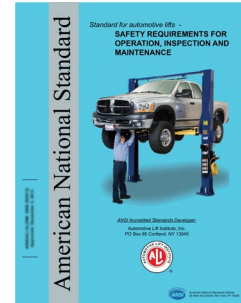

ANSI/ALI ALOIM Standard for Automotive Lifts. Safety Requirements for Operation, Inspection, and Maintenance.

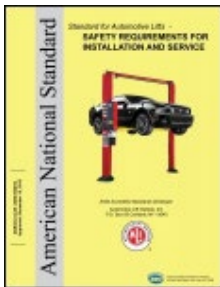

ANSI/ALI ALIS Standard. Safety Requirements for Installation and Service.

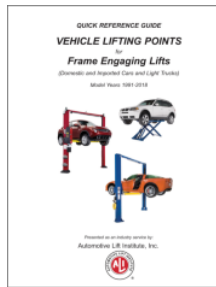

Guide to Hitting Vehicle Lifting Points for Frame-Engaging Lifts. Don't eyeball your lifting points, *know* where they are.



Lift Operator Safety Materials. Five safety documents in a single package.

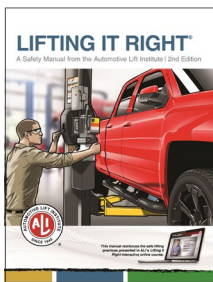

Lifting It Right. A hardcopy version of the *Lifting It Right* safety manual from the Automotive Lift Institute.



Uniform Warning Labels and Placards for 2-Posts. Labels in Mandarin, French Canadian, and Spanish are also available.



Safety Tips Card. Reminds your people of 13 key safety tips to follow daily.

Visit today and get the training and materials you need to work safely:
www.autolift.org/ali-store/.

BendPak®

30440 Agoura Road
Agoura Hills, CA 91301 USA
[bendpak.com](https://www.bendpak.com)